

Fairbanks-Morse Type "C-O" Heavy Duty  
Marine Oil Engines

0416002

INSTRUCTIONS NO. 2352B

FOR STARTING AND OPERATING

FAIRBANKS-MORSE  
Type "C-O"  
Heavy Duty Marine  
Engines

FAIRBANKS, MORSE & CO.  
(INCORPORATED)

Chicago, Ill.

Atlanta, Ga.  
Baltimore, Md.  
Boston, Mass.  
Buenos Aires.  
Cincinnati, Ohio.  
Cleveland, Ohio.  
Denver, Colo.  
Detroit, Mich.  
Indianapolis, Ind.  
Jacksonville, Fla.  
Kansas City, Mo.  
London  
Los Angeles, Cal.



Louisville, Ky.  
Milwaukee, Wis.  
Minneapolis, Minn.  
New Orleans, La.  
New York, N. Y.  
Omaha, Neb.  
Portland, Ore.  
Salt Lake City, Utah.  
San Francisco, Cal.  
Seattle, Wash.  
Spokane, Wash.  
St. Louis, Mo.  
St. Paul, Minn.

The Canadian Fairbanks-Morse Co., Limited

Montreal  
Calgary  
Edmonton  
Hamilton  
Ottawa  
Quebec

Saskatoon  
St. John, N. B.  
Toronto  
Vancouver  
Victoria  
Winnipeg

This pamphlet should be carefully read before attempting to do anything with the engine.

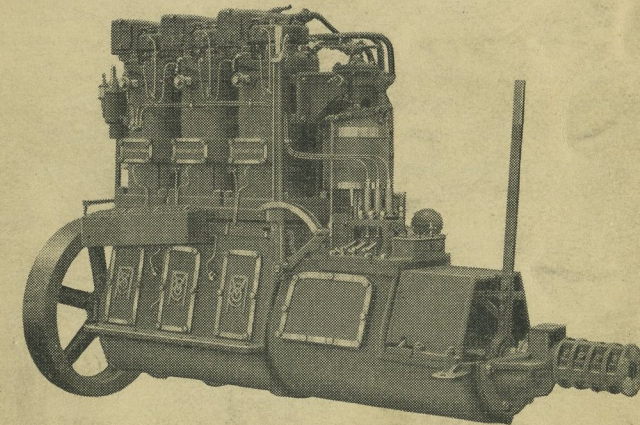

FAIRBANKS, MORSE & CO.  
(INCORPORATED)

(Copyright, 1916, by Fairbanks, Morse & Co.)

## Installation

### Keelson and Bilge Keelsons

In constructing a power boat, a Keelson is usually notched over the ribs and bolted to the keel. In addition to this, bilge keelsons or stringers are recommended, one on either side, and running nearly parallel to the keelson.

### Fasten Keelson Securely

These Keelsons also should be notched to fit over the ribs and securely fastened to them and the planking. The keelsons, coming under the motor foundation timbers and over a number of ribs, distribute the strain over a large area and contribute largely to the stiffness of the structure.

### Bore Shaft Hole

The hole in the shaft log should be at least from  $\frac{1}{4}$ " to  $\frac{1}{2}$ " larger than the propeller shaft, otherwise the swelling of the wood may bind the propeller shaft, causing loss of power. Care should be taken to see that it is of such a pitch or angle that the propeller will be entirely submerged, and that no part of the motor bed or flywheel will come in contact or touch the inside of boat aside from the foundation timbers.

### Stuffing Box

With a properly constructed dead-wood, there is no shaft hole lining needed except where the stuffing box is placed on the inside of the boat. With the last named arrangement a brass or iron tube may be used, the stuffing box fastened to the inboard end and the stern bearing to the outboard end.

### Line Up Accurately

The shaft hole being bored, stretch a fine line through the center of it; fasten the outboard end to a stick nailed to the stern of the boat; make the other end fast inside of the boat, go over the line carefully and see that it is in the exact center of the hole throughout the swing, and if the shaft hole has been properly bored a plumb bob held beside the line should point to the center of the keelson, providing the boat sets level.

### Face of Stern Post Smooth

The face of the stern post must be absolutely smooth and at exactly right angles with the line which has been stretched where the center of the shaft should be.

### Foundation

The foundation timbers should be securely fastened to keelsons at the given distance from the line, and at the same pitch or angle as the line.

### Check Measurements

These foundation timbers may run either athwart ship or fore and aft; in either case they must be securely fastened to every timber or plank over which

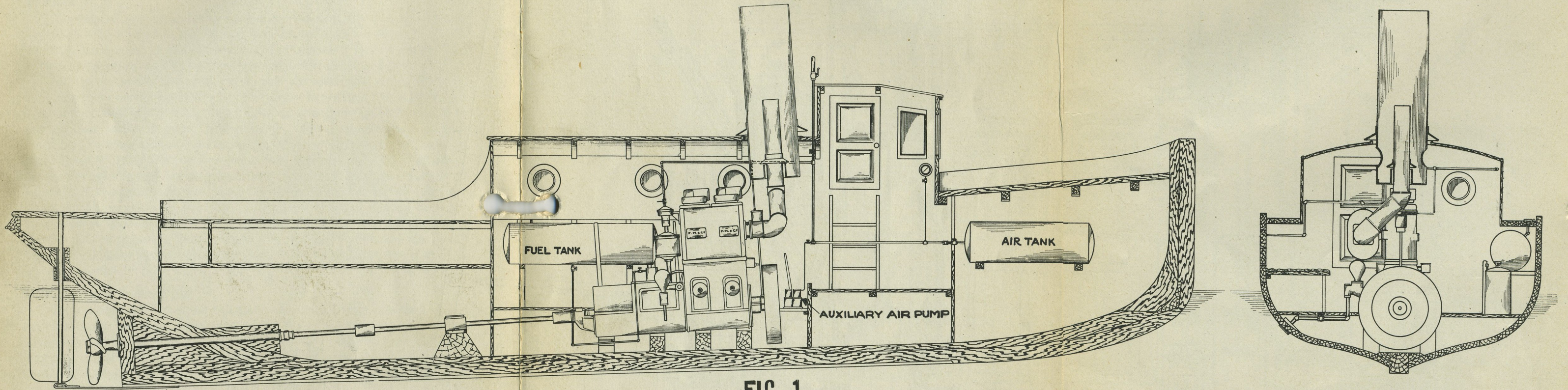

FIG. 1

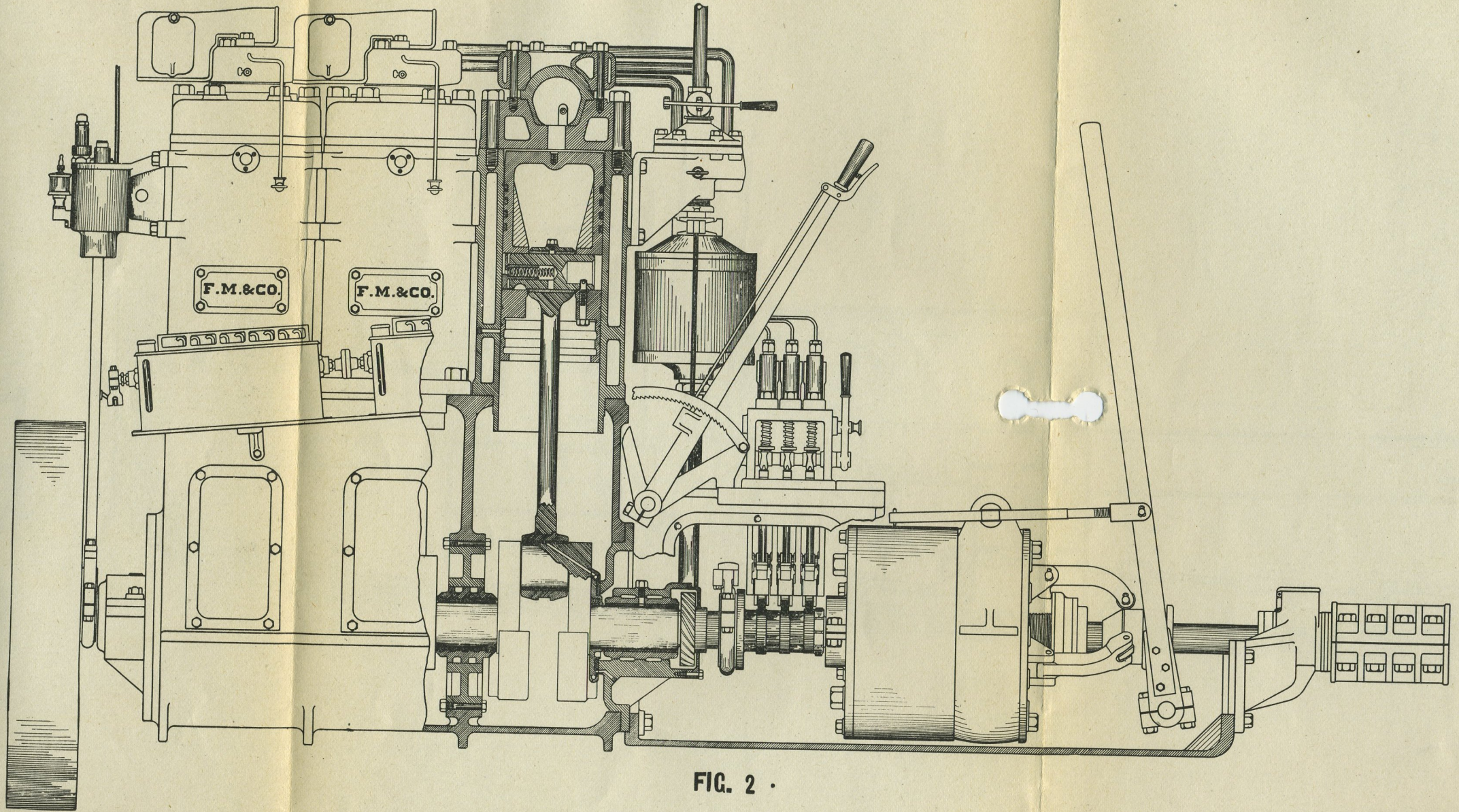

FIG. 2 .

they pass. The table of motor dimensions gives all necessary measurements, but it is well to check your measurements over when you receive the motor.

### Placing Motor

Place the motor on the foundation at the proper position fore and aft, and in line with the center of the shaft. The motor now being in place, compare the shaft ends and see that they line up properly. The least variation at this point, if allowed to remain, will cause undue friction and heating.

### Exhaust

The exhaust pipe must not be smaller in size than the companion flange furnished with the engine, and should lead into a stack as shown in Fig. 1. All sharp bends must be avoided, the use of 45° elbows is recommended. The bottom of the stack should occasionally be inspected and cleaned out.

In some boats it is not practical to pipe the exhaust as shown in Fig. 1, and some other arrangement will be necessary. In planning the exhaust pipe keep in mind that it is necessary to provide as free an exhaust as possible to get the best results in power and economy. Where an extremely long exhaust pipe becomes necessary all turns should be as easy as possible, avoiding sharp turns or other obstructions which will hold back the exhaust gases. Where the exhaust pipe requires short bends or extra length large pipe should be used. Use as many flanged unions as necessary to conveniently take the pipes apart for occasional cleaning. A properly installed exhaust pipe is a very essential part of a satisfactory operating engine and no reasonable expense should be spared to make it right. It is well to keep the pipe away from the engine so it does not interfere with the removing of the pistons or any other part.

### Cooling Water Outlet Pipe

The cooling water from the cylinder water jacket runs into the exhaust manifold jacket and from there overboard. The outlet from the rings which clamp down the vaporizer cap must run directly overboard by means of separate pipe independent of main cooling water. No valves should be placed in these outlet pipes.

### Water Intake Pipe to Pump

A flanged strainer should be placed on the outside and bolted together thru the planking with a flange on the inside, having a pipe thread at least the size of the water pump inlet. Put a few turns of white leaded candle wicking or other suitable packing under the inside flange and around the bolts. The seacock must not be smaller than the intake on the pump.

Use care in cutting threads on all pipes so that they will make up tight, using white lead on all joints of water and graphite and oil for exhaust pipe. Make all pipes run as direct as possible, avoiding elbows and short bends.

### Fuel Tank

The fuel tank must be securely fastened in the boat and placed high enough to insure a good flow of oil to the injection pump (119; Fig. 3). The

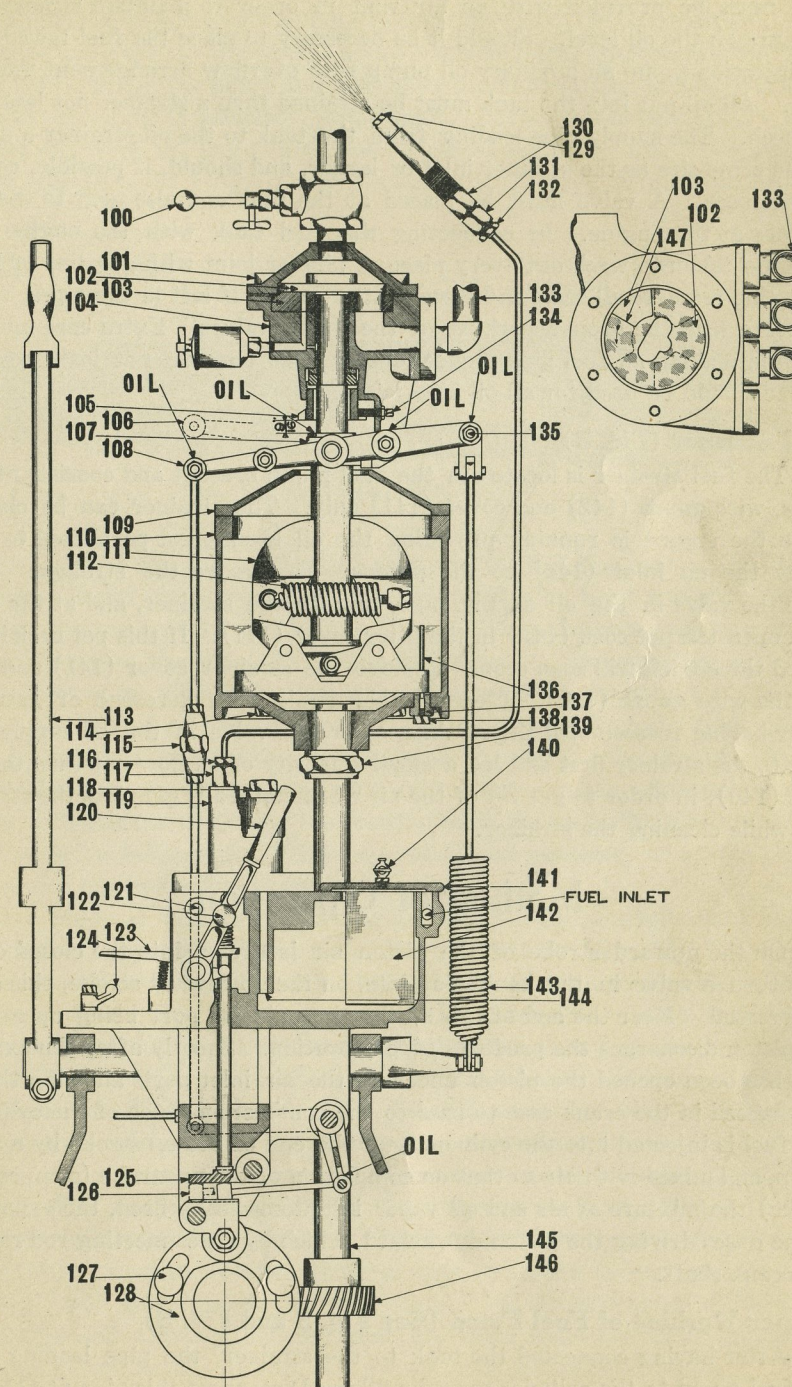

FIG. 3

tank must be provided with an air vent in order to maintain atmospheric pressure on the oil level. Should it be necessary to place the fuel tank below the injection pump an auxiliary oil pump with overflow arrangement must be used. All oil put into the tank must be strained thru a strainer not less than 50 mesh. The supply pipe leading from the tank to the oil strainer must be of the same size as the strainer inlet or larger, and should, if possible, consist of one piece. A valve must be placed at the tank and also next to the fuel strainer at the engine. In connecting the fuel tank with the engine care must be taken to wash out every piece of pipe or joint with gasoline or kerosene; this removes all scale and loose matter, which if left in the pipes, would interfere with the proper working of the pump valves. Extra care must be taken in making all fuel pipe connections so that they do not leak; soap or shellac should be used for all oil pipe joints.

### Fuel Strainer (Fig. 3)

The fuel strainer is located in the fuel pump bracket and consists of two parts, wire gauze (142) and cover (141) only. The strainer can be cleaned while the engine is running providing the oil level is not permitted to drop below the oil inlet (144) to the pumps. To remove the strainer: First close the valve in the oil supply pipe next to the strainer, and at the same time open the pet cock (140) in the filter cover (141). If this pet cock is left closed the engine will soon stop. Remove the strainer cover (141) and pull out the wire gauze (142). Clean it thoroughly with kerosene or gasoline. After having reassembled the strainer open the valve in the oil supply pipe next to the strainer first and let a small quantity of oil flow out thru the pet cock (140), in order to get rid of the air which naturally gets into the strainer box while cleaning the strainer.

## Method of Operation

On the upward stroke of the piston air is drawn into the closed crank case thru a valve in the handhole plate, on the downward stroke, this air is compressed. Near the end of this stroke the exhaust port being opened by the piston discharges the products of combustion. Shortly after the exhaust port has been opened the piston uncovers the air inlet ports allowing the air compressed in the crank case to pass to the combustion space of the cylinder. The fuel is injected into the cylinder near the end of the up stroke by a small pump, and mixed with air so that on completion of the up stroke (compression stroke) the mixture of air and oil vapor is automatically fired, the expansion of the gases driving the piston downward, which by its connecting rod rotates the crank shaft.

### Proper Working of Fuel Pump (See Fig. 3 and Fig. 5)

After having connected the tank to the strainer, the pipe leading from the fuel pump to the cylinder must be filled. Disconnect this pipe at (116) at the pump (Fig. 3). Put the lever (120) into the position shown. With the

handle (123) work the pump plunger up and down until the oil comes out at the discharge valve (117). Should the pump refuse to work, unscrew the discharge valve (117), prime the pump and hold your thumb over the outlet. Work the pump as before and if necessary, prime again. Put discharge valve (117), back in place and work the pump until the oil comes out at the top. Connect discharge pipe at (116) (Fig. 5) and disconnect it at (132) (Fig. 4) at the fuel

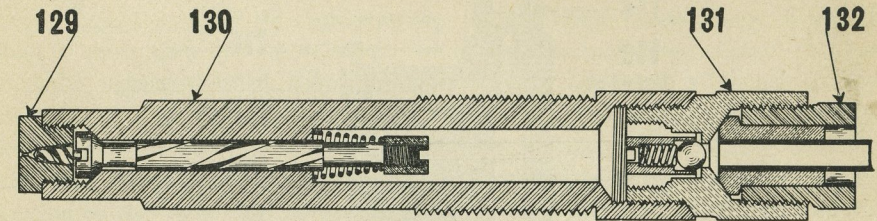

FIG. 4

injector. Work the pump again and soon the oil will flow over at the end of the pipe. Screw the nozzle (130) out of the cylinder head and put it into a position pointing upward as shown in Fig. 3. Work the pump again until the oil squirts out at the end (129) of the fuel injector. Be sure that all air is pumped out of it. This is the case when after working the handle (123) with a jerk, the flow of oil stops abruptly. The oil coming from the fuel injector must be in the form of a very fine spray and no heavy core should be in the center of the spray. If a heavy core exists clean out the whole nozzle thoroughly with gasoline especially the small spiral in the tip (129), also make sure that the valve holds tight. These operations are necessary on all the pumps in case of a multiple cylinder engine.

One essential feature of the engine, which for best results must always be in perfect mechanical order, is the fuel pump (119) (Fig. 5). To examine the pump, unscrew the pipe gland (116) and hold your thumb over the opening, or better, screw a plug into the opening. If you are able to move the plunger quite easily by means of the handle (123), it is a sign that one or all of the pump valves are leaky, or else there is air in the pump. If there is no air in the pump, and if the valves are tight, the oil has no other way to escape except along the pump plunger and therefore the plunger moves hard and only slowly. If it becomes necessary to remove the suction valve proceed as follows: The pump is shown in Fig. 5. Unscrew the plug (118). Then by means of the special socket wrench furnished with the engine, unscrew the plug (150). Turn the socket wrench around and screw its end into the valve seat (151) and pull it out of the pump body. Be sure and clean all the parts thoroughly and convince yourself that the valve seats are tight before you re-assemble the parts. Be sure and screw all the plugs down tight.

The fuel injector (130) must also be kept in good working order. If the valves are ground, they should be properly washed with gasoline and be ab-

solutely free from grit and dirt. A properly ground valve filled with gasoline and set aside should hold it for a long time without leaking, even if the valve springs were removed.

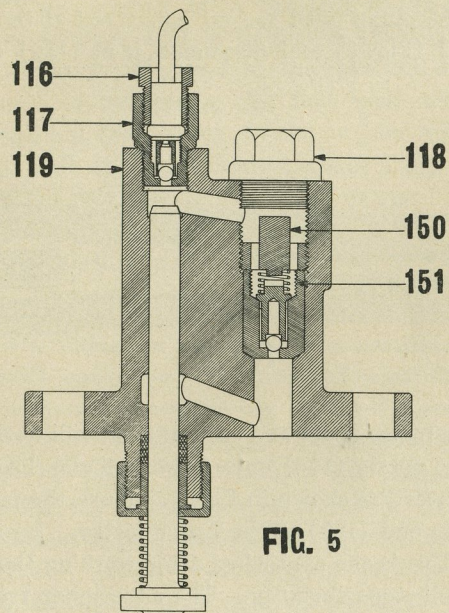

FIG. 5

### To Time the Oil Injection (See Fig. 3)

The fuel pump is operated by a cam (128). This cam is so arranged that the oil is sprayed into the cylinder when the engine piston is near its upper dead center. This cam, as it is set when the engine leaves the factory, works satisfactorily for many oils. There are, however, some oils which give better results when they are sprayed into the cylinder at an earlier or later point of the stroke. For this reason the cam is not keyed on the shaft but clamped to the face of the circulating water pump eccentric by means of two bolts (127). The cam is also held from moving endwise by a nut on the crank shaft. The circulating pump eccentric is keyed on the shaft. To change the timing of the oil injection, remove the large handhole plate of the reverse gear housing, unscrew the crank shaft nut and also the two clamping bolts (127). The circulating pump eccentric has on its face next to the cam a heavy line and the flange of the cam is graduated from 0° to 15° ahead, and from 0° to 15° back. Carefully note which line on the flange of the cam is pointing toward the line on the face of the eccentric. No set rules can be given for different oils, but when a change of timing is necessary it must be done very carefully. Never move the cam more than 5° for one setting, often a change of 2½° shows remarkable results. It is impossible to say in which direction the cam should be moved for a new oil, however, it is recommended to try first to inject the oil

earlier, that is, the cam should be turned in the direction the engine rotates. After the cam is in its new position be sure and tighten up the clamping bolts and nuts well, being careful not to rotate the cam when doing so.

## Speed Regulation

(See Fig. 3)

One of the most difficult points to explain and understand in the operation of an injection type oil engine is the action which takes place when the fuel is controlled by a governor. In a suction type gas engine the load may be increased until the maximum load is obtained when any further increase of load will result in slowing down the speed or stopping it, the limit being controlled by the amount of mixture introduced into the combustion chamber by atmospheric pressure. This is not true of the injecting type engine as atmospheric pressure does not control the amount of fuel injected. Consequently an overload within reasonable limits does not result automatically in a marked reduction in speed. To insure reliable action and ease in starting the capacity of the injection pump is made about double the full load requirements. The amount of fuel injected is controlled directly by the governor and any tendency to lower the speed of the engine as from increased load, is met by a corresponding action of the governor to increase the amount of fuel and keep up the speed.

Where the rated speed is 400 (340) R. P. M. the governor is so arranged that it does not act until the speed of the engine reaches about 385 (310) R. P. M., and up to the time it acts it gives the engine about twice as much oil as required at full load. The governor cuts off the oil entirely at approximately 415 (370) R. P. M.; thus the entire governor action takes place within a range of about 30 (60) R. P. M. change in speed. The speed at which each individual engine governor begins to act varies somewhat from the figures given above, due to slight variations in adjustment, but the range of change in speed from rated load to no load, remains approximately the same, even though the governor begins to act at much lower speed than 385 (310) R. P. M., a condition which obtains when the speed control lever is notched back to slow down the engine. Therefore, if the engine runs about 415 (370) R. P. M. idle and when loaded runs about 385 (310) R. P. M. or less it is probably getting the maximum amount of oil and is sure to be overloaded. The drop in speed from no load to rated load should never be more than approximately 20 (30) R. P. M. If the change is greater than this, it is good evidence that the engine is overloaded. The load may be lightened by means of a smaller propeller or by slowing down the engine by pulling back the speed control lever. This may be necessary when towing or running in shallow water.

The overload is detected by the appearance of the exhaust, by an excessive fuel consumption or by choking up and slowing down of the engine, with general unsatisfactory operation. The reason for this is that as the load increases, tending to slow the engine down, the governor gives the engine more

fuel in an attempt to keep up the speed of the engine. The fact that the engine does not materially decrease in speed when further load is put upon it does not show that the load it is carrying is too light. If the engine is operated on an overload and receives an excessive amount of fuel for any length of time, carbon will be formed in the Vaporizer, and if the operation is continued trouble may result from the ports in the cylinder fouling with carbon, resulting in very unsatisfactory operation.

The speed of the engine is controlled by a centrifugal governor (111) which is set so that the engine runs the speed stamped on the name plate. This is the highest speed the engine should run at full load. The speed, however, can be lowered in two ways: By releasing the tension of the governor springs (112), or by using the hand control. If the control lever (113) is moved towards the propeller, the speed of the engine is reduced. The hand control consists mainly of a spring (143) which counteracts the governor springs (112). The control spring (143) must have very little or almost no tension when the control lever (113) is in its most forward position, and the governor lever (108) is in its upper position (106), as shown in dotted lines. Therefore, the control spring (143) has as much tension when the governor lever is in its lower position as the movement of the lever at the point (135) may be.

### To Adjust the Governor (Fig. 3)

The governor is properly adjusted when the engine leaves the factory. The lift of the governor sleeve (107) is  $\frac{9}{16}$ ". This lift of the governor sleeve is adjusted by means of the nut (105) which is held from turning by the set screw (134). It is very important that the face (126) of the regulating link is flush with the face (125) of the intermediate speed regulating lever when the governor lever (108) is in its upper position (106). This position of the regulating link is shown in dotted lines. In this position the governor cuts out the oil entirely. All the principal parts of the governor run in oil and wear should, therefore, be very slight. If however, due to slight wear the regulating link and the intermediate speed regulating lever do not line up any more, they can be brought into this position by loosening up the turnbuckle lock nuts and turning the turnbuckle (115). This turnbuckle has right and left hand thread. While this is done the governor lever (108) must be pried up so that the upper sleeve face (107) touches the face of the adjusting nut (105). The lift of the governor sleeve must first be adjusted to  $\frac{9}{16}$ ". As mentioned above, the governor housing (110) is partly filled with oil. Whenever oil is poured into the housing the plug (138) must first be removed and oil poured in through one of the holes in the housing cover (109), until it overflows thru (136). To drain the housing remove the plug (137).

### To Adjust the Governor Springs

Remove the screws which hold the governor housing cover (109), also the four nuts (114), at the bottom of the governor housing and the shaft nut (139). The governor housing will now drop down and expose all the working parts of the governor and also the springs (112). If, with normal load on the engine

the speed should be below 400 (340) tighten up both governor springs the same amount, but not more than  $\frac{1}{8}$ " at a time. Remember, however, that the engine must not exceed the speed stamped on the name plate.

### Lubricating System

The engine is provided with a mechanical sight feed oiler driven by a ratchet, forcing oil to the cylinders and bearings. A high grade, medium heavy, gas engine, lubricating oil must be used. The number of drops fed to the various parts should be as follows:

Cylinder, by-pass side.....	30 to 35 drops
Cylinder, exhaust side.....	12 to 15 drops
Piston pin.....	12 to 15 drops
Main and intermediate bearings.....	15 to 20 drops
Crank pins.....	20 to 25 drops
Air compressor eccentric.....	6 to 8 drops
Water pump eccentric.....	6 to 8 drops
Fuel pump mechanism.....	6 to 8 drops
Governor shaft step bearing.....	8 to 10 drops

In some cases the amount of oil can be cut down but this should be done very carefully.

The amount of oil can be adjusted by turning the buttons on the lubricator cover with a screw driver. No attention to the lubricating pumps is required except to observe that they always feed properly, and to see that there is at all times a sufficient quantity of clean oil in the reservoir. The oil should be run through a fine mesh wire strainer inserted in a funnel, when the oiler is filled. The cover of the oiler should be in place at all times except when the oiler is being filled. The oiler should be drained occasionally and washed out with gasoline or kerosene. It is also wise to wipe out the crank case occasionally.

## Air Starter

### (Fig. 3)

All engines are started with compressed air. An air compressor (Fig. 6) to furnish the necessary air, is mounted on the engine and driven by an eccentric. The first time, however, when the air receiver is empty it must be pumped up by means of a hand air pump, preferably a good tire pump to about 100 lbs. gauge pressure. When installing the air tank an extra good valve must be placed next to the air receiver and this valve must always be closed tightly when the safety valve, mounted in the air compressor head, blows off, or if the engine is stopped; all pipe connections must be perfectly tight. The air compressor suction valve is provided with a cut out (160) (Fig. 6), which stops the compressor from working. This cut out (160), when screwed down, holds the suction valve (161), off its seat, it is however so arranged that it cannot be screwed down too far.



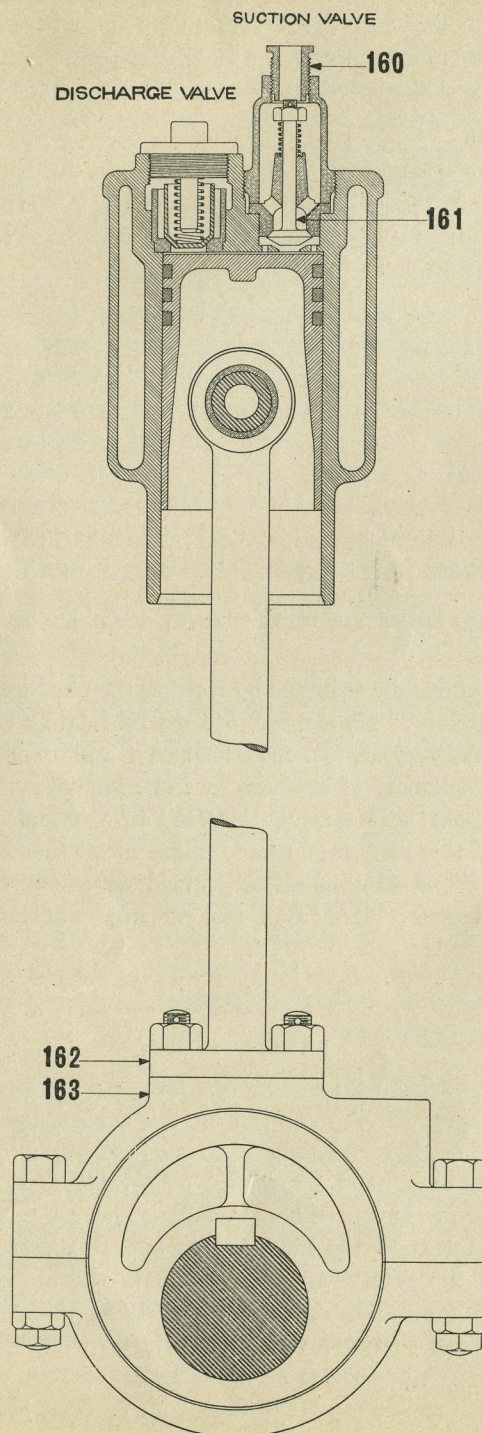

FIG. 6

The air compressor should easily pump up to 175 lbs. gauge pressure when it is in good working order. If, however, the air pressure builds up too slowly, the valves should be inspected, and also the clearance between the cylinder head and the piston. This clearance should be as near as possible  $\frac{1}{64}$ ". The clearance may increase due to wear of the eccentric strap or the piston pin bushing. If the wear is considerable the eccentric strap should be rebabbitted and the piston pin bushing renewed. However, the clearance can also be taken up by putting shims between the air compressor rod flange (162), and eccentric strap flange (163). A good way to try the clearance between the cylinder head and the piston is to remove the discharge valve and drop a small piece of soft lead wire down on the piston. If the engine is turned over and this piece of lead taken out it will show exactly the amount of clearance, and deducting  $\frac{1}{64}$ " will give the thickness of the shim which should be put between the eccentric strap and rod flange.

### Air Starting Valve (Fig. 3)

Each engine is equipped with an air starting valve. Pipes (133) lead from this starting valve to check valves which are bolted to the cylinders. These check valves are in operation for a few seconds only when starting up, otherwise they remain closed. Nevertheless some carbon formation is possible in these valves. They must be inspected occasionally, kept in good working order and ground in from time to time.

The air starter disc is driven by spiral gears. Two teeth of the crank shaft gear, and one tooth of the vertical shaft gear, carry center punch marks. If the gears are taken apart, make sure, in reassembling, that the marked tooth of the vertical shaft gear goes between the two marked teeth of the crank shaft gear. These gears run in oil but nevertheless they will wear slightly in time. This necessitates an adjustment of the air starter valve. It is important that the disc (102), which has one slot, and is driven by the vertical shaft, begins to open up one of the slots in the stationary disc (103) when the piston in the cylinder to which the stationary slot is connected is exactly at its upper dead center. To time the air starter valve properly it is best to set the piston next to the reverse gear in its upper dead center. This is done by turning the flywheel until a  $\frac{1}{4}$ " hole drilled at the edge of the flywheel rim is directly opposite of a  $\frac{1}{4}$ " hole drilled into the side of the air compressor eccentric rod which faces the flywheel. If this is done, remove the air distributor cover (101) and move the stationary disc (103) around so that the edge (147) of the rotating disc (102) is just uncovering the port in the stationary disc (103) as shown in Fig. 3. Fig. 3 shows the arrangement for a three cylinder engine but the same rules apply for engines with more or less than three cylinders.

## Starting the Engine

Before the engine can be started, the combustion chamber cap on top of the cylinder must be warmed up. A special instruction card is furnished for this operation.

### To Set the Engine for Starting

This is not necessary for the four or more cylinder engines as these start in any position. The flywheel of the three cylinder engine has three broad painted strips on its face next to the cylinders. If any part of these strips is covered by the air compressor eccentric rod, the flywheel must be turned until no part of the strip is covered. The flywheel of the two cylinder engine has two strips painted on its face and must be turned in the same manner as a three cylinder engine. The single cylinder engine must always be set for starting and in such a way that a small strip on the face of the flywheel comes directly opposite the air compressor eccentric rod. Make sure that the compression relieve valves are open before putting the bar into the flywheel, and that the fuel pump plungers are held up; in other words move the lever (120) until its spring plunger (122) jumps into the hole (121). **Never stand directly in front of the starting bar.**

### To Start the Engine

Make sure that the crank case has been drained by the drain cocks provided for this purpose. Assuming that the force feed oiler tank has been filled, disconnect the rod which connects the ratchet arm to the air compressor eccentric rod and move the ratchet by hand long enough to fill all the pipes leading from the oiler to the bearings and cylinder. Neglecting this may result in a hot bearing and serious damage right from the start. Replace the ratchet rod and oil both ends. When the oiler is provided with an auxiliary hand crank it is not necessary to disconnect ratchet drive to fill oil pipes by hand. This operation is only necessary when the engine is started the first time, or if it has been standing idle for a few days. Oil all the governor links and rods where the word "oil" is marked on Fig. 3.

Set the speed control lever (113) in its starting position, as far forward (toward the cylinder) as it will move. Pump about two strokes of fuel into each cylinder by means of the handle (123) or (120). Be sure that the lever (120) stands in the position shown in Fig. 3.

Now open air valve (100), Fig. 3, and keep it open until the engine fires and speeds up. Shut off the air and pull the speed control lever (113) slightly backwards to reduce the speed.

In case the engine stops firing pump one or two more strokes of oil into the cylinders by means of the handle (120). While pumping the spring plunger (122) should be held out so that it cannot jump into the hole (121). If necessary open the air valve (100) again.

After a few seconds run, the speed control lever (113) can be set in the full speed position again. By means of this control lever the speed of the engine can be regulated at the will of the operator. The governor has complete control over the engine at all speeds and loads.

### To Stop the Engine

Pull the levers (120) far enough so that the spring plunger (122) jumps into the hole (121). Perform this operation slowly. If, in case of a multiple

cylinder engine it is desired to shut off only one cylinder, the pump plunger may be raised up by means of the handle (123), and held so by means of the catch (124), Fig. 3. This, for instance, should be done if one of the combustion chamber caps gets cold. It would be unwise to flood the cylinder with oil while the cap is heated.

## Engine Bearings

All of the bearings are removable and renewable, the main bearings being cast iron shells, lined with genuine babbitt. The end bearings of the crank shaft are supported by flanges centered and bolted to the ends of the crank case, and this crank case is so designed that the intermediate bearings, as well as the end bearings, may be removed without removing the crank shaft from the engine. This is a very desirable feature, as it permits the removal of any of the main bearings of the engine for inspection or replacement, without tearing down the whole engine, and as the upper halves of all of the crank shaft bearings are interchangeable with their lower halves, it is possible to make a temporary repair of a worn bearing without the aid of new parts.

## Caution

Remember that this engine will operate on lubricating oil, therefore, **DO NOT UNDER ANY CIRCUMSTANCES POUR LUBRICATING OIL DIRECTLY INTO THE CRANK CASE** for the purpose of furnishing splash lubrication or for any other purpose. Such practice is dangerous, as the splash will be carried through the bypass into the combustion chamber where the oil will burn and cause the engine to speed up; as the governor can have no control over such splash feed, any surplus of oil in the base will result in dangerously high speed. Be sure to drain crank case compartments before starting engine.

## Reverse Gear

The forward drive consists of a clutch of the multiple disc type. The plates (179) must run dry, and for this reason two holes (178) are provided in the clutch case to drain any oil which may run along the bushing of the gear drum into the clutch case (177). **(Do not put oil on clutch plates.)**

A threaded collar (180) mounted on the clutch hub (181) serves, when tightened up, to increase the pressure on the plates (179) to prevent slipping. This collar is held in place by a lock (171). The clutch plates (179) can be inspected by removing the clutch case (177). The clutch hub is prevented from slipping by the split collar (182), which is let into the shaft, and the nut (183).

The reverse drive consists of a set of gears and pinions and two shoes to clamp the drum. The gears must run in oil. A heavy steam engine cylinder oil must be used. **(Use no grease.)** A plug (170) is provided for this

purpose. Sufficient oil must be kept in the drum to lubricate all the gears and pinions thoroughly, however, not to such an extent that it flows out of the drum head bushing (174) too freely.

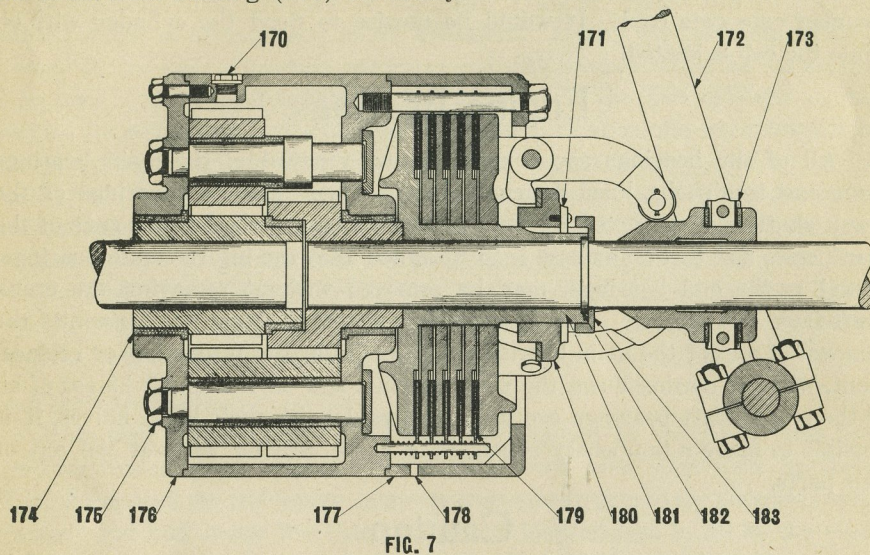

FIG. 7

The clamping shoes are connected by a rod which runs across the gear drum. This rod is threaded and provided with a nut to take up wear and increase the pressure on the shoes. Care should be used not to adjust the shoes so that they will drag on the drum when the operating lever (172) is in its neutral or go-ahead position.

To inspect the gears and pinions remove the nuts (175) and then the split drum head (176).

The slip collar (173) is under pressure at the moment the clutch or the reverse is thrown in and, therefore, requires oil, and it must not be neglected.

## Thrust Bearing

The thrust bearing for the 15, 30, 45 and 60 horse power engines has on its reverse end a threaded collar with holes for a wrench at its rim which serves to take up wear of the forward as well as reverse thrust. A lock screw is provided to keep this collar from turning.

## Miscellaneous Instructions

1. If the exhaust is smoky pull the speed control lever back one notch at a time until the exhaust is almost clear. The exhaust becomes smoky if the engine is overloaded or if the combustion chamber caps get red hot. If only one combustion chamber cap is hot the fuel pump for that cylinder may be put out of action by holding down the handle (123), by means of the catch (124), and the cap left to cool for about five minutes.

2. Always turn on the water leading to the rings which hold down the combustion chamber caps as soon as any load is put on the engine. Shut it

off only when the engine is expected to run idle longer than five minutes. Do not shut off the water when maneuvering.

3. Oil the reverse gear, lubricator drive rod and governor lever pins and rods.

4. The oil cup screwed into the air compressor cylinder should only feed about 2 drops of oil per minute.

5. Keep the air suction valves mounted on the crank case hand hole plates in good working order. Inspect them occasionally and when reassembling them make sure that the valves cover the slots properly and that the small springs are in the center of the small strips connecting the two concentric rings. Be careful not to loose these small springs.

6. If after the engine has been in use for some time, it seems to lag in power capacity, an inspection should be made of the **crank case air suction valves**, cylinder and exhaust ports. The hand hole plates at the exhaust manifold will be of assistance in examining the ports. The piston and rings can be seen thru the openings covered by hand hole plates on the cylinder and exhaust manifold. It should not be necessary to clean the exhaust manifold and pipes frequently.

7. When a loss of compression is noticed, the crank case air suction valves and the pistons should be inspected. The piston can be easily removed by taking off the cylinder head and disconnecting the connecting rod bolts at the crank pin end. This gives complete access to all interior parts of the engine. The piston rings are of cast iron and should remain free in their grooves. Any accumulation of carbon from lubricating oil which tends to stick the rings should be washed out with alcohol or kerosene; otherwise the rings are not to be changed or adjusted in any way until necessary to replace them. If the rings have been allowed to stick fast, the compression and explosion will blow past them and the combustion will be poor, due to poor compression. If the rings are gummed fast in the grooves, a hot solution of lye and water will free them readily.

8. The fuel must at all times be kept fluid and warm enough for pumping.

9. If the fuel pump and injector valves become leaky, they must be very carefully ground into their respective seats with the use of a fine grade of carborundum paste, flour of glass, or pumice stone, but not with emery, as even the finest grades of this are too coarse.

10. All bolts and nuts should be carefully tightened up after the engine has been installed and thereafter the inside of the crank case should be inspected about once a week.

11. Drain cylinders, cooling water pump, exhaust manifold and clamping rings for the combustion chamber caps if there is the remotest possibility of freezing weather. There is one drain cock on each clamping ring, two at the water pump and one at the exhaust manifold.