

PARTS CATALOG

CONTRACT _____
PURCH. ORDER _____



APPLIES ONLY TO THE FOLLOWING ENGINES
12719

BORE 9" STROKE 12"
NO. CYL. 4 TYPE Marine - R.H.
MODEL _____

WARNING
THIS CATALOG MAY CONTAIN EXTRA GROUP SHEETS WHICH DO NOT APPLY TO THE ENGINES
— — — NOTED ABOVE — — —
USE ONLY THOSE SHEETS LISTED ON THE
INDEX SHEET

ATLAS IMPERIAL DIESEL ENGINE CO.
OAKLAND CALIF. MATTOON ILL

TABLE OF CONTENTS

The material in the Instructions has been arranged in sections each dealing with a specific subject or subdivision of the engine. The sections are arranged alphabetically and the Titles and main contents are listed below.

TC6 - Ed 1 (1)

	<u>Section</u>	<u>Page In Section</u>
GENERAL ENGINE DATA - - - - -	A	
FUEL AND LUBRICATING OILS - - - - -	B	
INSTALLATION INSTRUCTIONS - - - - -	C	
OPERATING INSTRUCTIONS - - - - -	D	
LOWER BASE, CRANKSHAFT AND BEARINGS - - - - -	F	
Main Bearings - - - - -		1
Crankshaft Alignment - - - - -		1
CYLINDER AND LINER, CYLINDER HEAD AND VALVES - - - - -	H	
Cylinder and Liner - - - - -		1
Cylinder Head and Valves - - - - -		1
Air Starting Valves - - - - -		2
PISTON AND CONNECTING ROD - - - - -	K	
Connecting Rod Bearings - - - - -		2
CAMSHAFT AND VALVE OPERATING GEAR - - - - -	L	
Camshaft, Camshaft Removal and Disassembly - - - - -		1
Camshaft Assembly, Lifter and Push Rods - - - - -		2
Valve Timing Table, Flywheel Markings - - - - -		3
Inlet & Exhaust Valve Timing - - - - -		4
Starting Air Valve Timing - - - - -		4
FUEL SUPPLY SYSTEM - - - - -	N	
Fuel Transfer Pump - - - - -		1
Day Tank and Filter - - - - -		1
FUEL INJECTION SYSTEM - - - - -	O	
High Pressure Fuel Pump - - - - -		1
Fuel Rail and Tubing - - - - -		2
Fuel Pressure Regulating Valve - - - - -		3
Spray Valve and Servicing - - - - -		4
Spray Valve Timing - - - - -		8
Balancing Engine for Cyl. Load Distribution - - - - -		9
GOVERNOR - - - - -	Q	
REVERSE GEAR AND THRUST BEARING - - - - -	S	
Planetary Transmission - - - - -		2
Clutch - - - - -		3
Reverse Gear Brakes - - - - -		4
Thrust Bearing - - - - -		4
Dismantling and Adjustment - - - - -		5
LUBRICATING OIL SYSTEM - - - - -	T	
Lubricating Oil Pumps - - - - -		1
Filter - - - - -		2
Oil Cooler, Lubricator and Drive - - - - -		3
COOLING WATER SYSTEM - - - - -	W	
Circulating Water Pump - - - - -		1
AIR COMPRESSOR - - - - -	X	
MAINTENANCE AND INSPECTION - - - - -	Z	
Smoky Exhaust - - - - -		1
Maintenance Routine - - - - -		2
PARTS CATALOG (Sub-Assemblies, Auxiliary Equipment)		

GENERAL ENGINE DATA

The Atlas Imperial Diesel Engine described herein is of the heavy duty, solid injection, full Diesel type, designed especially for reliability and a long life of trouble-free operation. It operates on the four stroke cycle, the sequence of operation being as follows:

- 1st Stroke On the downward or suction stroke of the piston, the inlet valve is open and pure air is drawn into the cylinder through the air inlet manifold.
- 2nd Stroke On the second or compression stroke, this air is compressed to about 400 lbs. per square inch, the heat of compression raising the air temperature to a point above the ignition temperature of the fuel. Just before the piston reaches top center, the injection is completed shortly after the piston has passed the top dead center.
- 3rd Stroke On the power stroke the injected fuel oil burns, increasing the pressure within the cylinder, and driving the piston down through its working stroke. Shortly before bottom center position is reached, the exhaust valve opens.
- 4th Stroke As the piston returns toward the head, the burned gases are discharged through the exhaust valve, and as the piston reaches top center the exhaust valve is closed, the inlet valve is opened, and the cycle is repeated.

The following engine data applies to engines covered by this book:-

MODEL →	MARINE		STATIONARY	
	3HM763	4HM763	3HS763	4HS763
NO. OF CYL.	3	4	3	4
BORE	9"	9"	9"	9"
STROKE	12"	12"	12"	12"
RATED OPERATING SPEED	325 RPM	325 RPM	400 RPM	400 RPM
HORSEPOWER RATING	75	110	90	120
PISTON SPEED (FEET PER MIN.)	650	650	800	800
LUBE OIL PUMP PRESSURE (GEAR TYPE)	4.3 G.P.M.	4.3 G.P.M.	5.4 G.P.M.	5.4 G.P.M.
LUBE OIL PUMP SUMP (GEAR TYPE)	5.9 G.P.M.	5.9 G.P.M.	6.2 G.P.M.	6.2 G.P.M.
FUEL TRANS. PUMP (GEAR TYPE)	1.6 G.P.M.	1.6 G.P.M.	1.9 G.P.M.	1.9 G.P.M.
APPROX. WEIGHT (WITH FLYWHEEL)	12600 LBS.	14760 LBS.	13385 LBS.	15470 LBS.

Section A

High Pressure Fuel Pump - Single Acting

Operating Speed	- - - - -	1/2 Engine RPM
Bore	- - - - -	1/2"
Stroke	- 3 Cyl. - - - - -	1 1/4"
	- 4 Cyl. - - - - -	1"
No. of Pumps	- 3 Cyl. - - - - -	1
	- 4 Cyl. - - - - -	2

DATA FOR ATTACHED AUXILIARIES:

Air Compressor - Single Acting		
Bore	- - - - -	4"
Stroke	- - - - -	3 1/2"
Operating Speed	- - - - -	Engine R.P.M.
Circulating Water Pump - Centrifugal		
Operating Speed	- - - - -	4 Times Engine R.P.M.
Bilge Pump - Single Acting		
Bore	- - - - -	3"
Stroke	- - - - -	3-1/4"
Operating Speed	- - - - -	1/2 Engine R.P.M.

PRESSURES:

Lubricating Oil Pressure	- - - - -	30 to 45 lbs./Sq.In.
Cooling Water (at pump discharge)	- - - - -	20 lbs./Sq.In.MAX.
Fuel Oil (at transfer pump disch.)	- - - - -	10 lbs./Sq.In.MAX.
Fuel Oil (in rail)	- - - - -	1500 to 4500 lbs./Sq.In.
Starting Air Pressure	- - - - -	125 to 250 lbs./Sq.In.

TEMPERATURES:

Cooling Water (Engine Outlet) - direct	cooling - - - - -	125° F. Max.
Cooling Water (Engine Outlet) - Indirect	cooling - - - - -	160° F. Max.
Lubricating Oil (Cooler Outlet)	- - - - -	130° F. Max.
Exhaust Temperature (at full load full speed)	- - - - -	750° F. Max.

EXPLANATION OF TERMS "RIGHT" AND "LEFT" HAND WHEN APPLIED TO COMPLETE ENGINES

Atlas engines are built and designated as Right or Left Hand Engines. This designation has no bearing as to the engine location or arrangement in a vessel or power plant. An engine can be easily identified by facing the governor or gear end of the engine and if the governor is to the Left of the observer, the engine is Right Hand. If the Governor is to the Right of the observer the engine is Left Hand.

FUEL AND LUBRICATING OILS1. RECOMMENDED FUEL OIL SPECIFICATION

Viscosity - - - - -	35 to 70 S.U. Seconds at 100° F.
Gravity (A.P.I.)- - - - -	Minimum 24°
Conradson Carbon (A.S.T.M.-D189)-	Maximum 0.5%
Ash - - - - -	Maximum 0.05%
B.S.&W. - - - - -	Maximum 0.1%
Sulphur (A.S.T.M.-D129) - - - - -	Maximum 1.0%
Ignition Quality- - - - -	40 to 60 Cetane Number or equivalent in other ignition index.

2. EFFECT OF FUEL PROPERTIES ON PERFORMANCE

As adjusted at the factory the engine will operate satisfactorily on fuels with viscosities per above specification. It is possible to use thinner fuels but the operation is apt to be "snappy" and it may be difficult to maintain even cylinder load balance at varying loads. Fuels with viscosities less than 35 S.U.S. may also require special spray tips with smaller orifice holes than standard or the fuel pressure may have to be reduced. On the other hand fuels with high viscosities may require larger spray orifices than standard, increased fuel pressure and in extreme cases longer period of injection. To insure good operation it is recommended that the viscosity be held to the specification.

The gravity is of secondary importance. A minimum of 24° A.P.I. is merely given since heavier fuels generally require special treatment, such as heating and centrifuging, before they can be burned successfully.

The "Conradson Carbon" or "Carbon Residue" in the oil is an index to the amount of carbon which will form in the combustion chamber. Fuels with high "Conradson Carbon" may cause carbon to build up on the spray valve tips to such an extent that the fuel sprays are deflected causing poor operation and smoky exhaust. The higher the Conradson Carbon the more frequently will it be necessary to clean the spray valve tips. Experience also indicates that maintenance costs will be higher when fuels with high "Carbon Residues" are used.

The Ash content of a fuel is a measure of the amount of mineral material it contains. After burning the mineral residues are abrasive and it is consequently important that the Ash content be limited to 0.05%. If the content is higher rapid wear of cylinder liners, pistons and rings will result.

The item B.S.&W. (Bottom Sediment and Water) is an index to the fuel's cleanliness. It is good economy to use clean fuel and store it in clean tanks. Cleanliness in handling the fuel is also important (See paragraph entitled "Importance of Cleanliness in Fuel Handling" in Section N).

When the fuel oil is consumed in the engine Sulphur burns to Sulphur-dioxide. Under normal operating conditions most of this gas is ejected with the exhaust gases. If, however, temperature conditions are low enough, that is, if the engine is idling at low speed and under cold conditions, the sulphur-dioxide gas combines with condensed water vapors to form a corrosive acid which will attack metals used in the engine and exhaust system. It is consequently particularly important to hold the sulphur content low in fuels used for engines subject to variable loads with long periods of idling and also for engines subject to frequent starting and stopping.

The Cetane number of a fuel is an index of the ignition quality. Low Cetane values produce excessive knocking. Excessively high Cetane fuels cause high exhaust temperatures and smokiness of the exhaust.

Although the Flash Point does not affect the suitability of a diesel fuel it is well to specify a minimum of 150° F. since state laws and Classification Societies generally require this minimum. The Pour Point of the fuel should be at least 15° F. below the lowest temperature to which the fuel storage tank is subjected.

3. LUBRICATING OIL

We recommend that a good grade of Marine type pure mineral oil be used in these engines. The oil should be stable under the temperature conditions encountered in the engine and should be resistant to oxidation and sludging. In general, regarding quality of lubricating oil we refer you to a Lubrication Instruction Book which will be sent to any customer or operator requesting it. This book contains some good pointers on the selection and care of lubricating oils.

Section B

It is not necessary to use compounded oils, i.e., oils containing additives, inhibitors, anti-oxidants, carbon removers, etc. in Atlas Engines. There are, however, many good compounded oils on the market and these may be used providing extreme caution is exercised and the action of the oil in the engine is observed closely.

When a pure or "straight" mineral oil is used some carbon or other deposits will generally be found in the crankcase and sump tank. The amount of these deposits depend greatly on the quality of the oil which has been used and for good grades of oil the deposits are not excessive and in any way harmful to the engine. The chemicals contained in the compounded oils enable these oils to carry the carbon and other constituents of the usual crankcase deposits in suspension. The compounded oils also have a strong tendency to break loose and carry away any existing crankcase deposits and since there is a limit to the amount that can be carried in suspension clogging of filters and oil lines may result. It is consequently of utmost importance to thoroughly clean out the crankcase, oil lines and sump tank before changing from a straight mineral oil to a compounded oil. As an added precaution we suggest that the first batch of compounded oil be used only for about 25 hours and then drained off. These precautions apply also when changing from one compounded oil to another compounded oil of different make or brand.

If a compounded oil is used the non-corrosiveness of this oil must be looked into very carefully. In this connection the Engineering Dept. of the Atlas Imperial Diesel Engine Co. is available for consultation and they will be glad to advise whether or not an oil is suitable for use in this engine.

With regard to viscosity grade our recommendations are that the viscosity at 130° F. be between 235 and 270 Secs. Saybolt Universal. This corresponds to an S.A.E. viscosity rating of 30 to 40. In other words, the oil to be used should be a heavy S.A.E. 30 or a light S.A.E. 40 oil.

In regard to drainage periods we suggest that the first batch of oil be drained after 100 hours of service. Thereafter the suggested drainage period is 200 to 250 hours. This period may be lengthened somewhat on engines which are equipped with waste packed filters. In that case if the filter cartridge is changed before the oil is badly discolored and loaded up with insolubles or foreign particles, drainage periods of 400 to 600 hours can be used. In the cases where no waste packed filters are used the oil will of course not be "worn out" after 200 hours of service if it is of a good grade. It will, however, be dirty and will contain insolubles which should be removed from the lubricating oil before it is re-used.

The same lubricating oil as used in the crankcase of the engine is also suitable for use in the mechanical lubricator. In the case of the mechanical lubricator, however, it is highly desirable that new oil be used.

INSTALLATION INSTRUCTIONS1. PREPARING THE ENGINE BED

The success of a Marine engine installation depends greatly upon the construction of the foundation and upon the care exercised in lining up the engine to the propeller shafting. Poor installations will result in excessive vibration and continual change in engine alignment. The result is poor performance and failure of vital parts. For this reason Atlas Imperial Diesel Engine Co. cannot guarantee an engine unless the engine foundation (engine bed) is strong and rigid enough to prevent vibration and changes in alignment.

The importance of rigidity in the engine foundation cannot be over-emphasized and it must be securely fastened to the hull of the vessel so as to be virtually a part of the hull construction. For installations in old hulls, where the rigidity of the hull is questionable, the foundation should be extended fore and aft as far as possible; twice the length of the engine is suggested. Stiffeners should be fitted to prevent the foundation from twisting and weaving. In twin screw installations it is advisable that both foundations be stiffly connected and braced to each other and to the hull. Steel foundations should be welded or riveted. Avoid bolts or screws which may work loose.

When preparing the engine foundation always obtain certified outline prints. Do not use figures or cuts in bulletins or sales literature. The top faces of the foundation must be straight and should be lined up so that they are parallel to the propeller shafting. Athwartships the two top faces should be level. The foundation should be constructed so as to allow 1" to 1½" thick shims or chocks between the engine supporting flanges and the top faces.

2. INSTALLING THE ENGINE

The engine should be lowered onto the foundation and allowed to rest on the leveling screws. For wooden foundations provide steel plates of sufficient area and thickness for the leveling screws to rest on. (Min. 4" x 4" x ½" to ¾" thick.) Shift the engine sideways until the centerline of the crankshaft lines up with the centerline of the propeller shafting. Then by means of the leveling screws adjust the height until the centerline of the crankshaft exactly lines up with the centerline of the propeller shafting. Also level the base athwartships. When alignment in all planes is at hand the following check should be made.

- a. Turning over shaft there should be no binding between the centering spigot and recess of the two coupling halves.
- b. The faces of the coupling halves should be parallel regardless of the angle through which either or both shafts are turned. With the propeller coupling half held against the engine coupling half, but not bolted, it should not be possible to insert a 0.003 in. feeler at any point between them. Check at top and bottom and the two sides before bolting flanges together.

If engine has been installed before launching it is advisable to temporarily bolt it to the foundation at this time. It is not advisable to proceed any further before launching unless the hull is extremely rigid. When the vessel is afloat the alignment should again be checked and if found satisfactory a chock should be carefully fitted at each holding down bolt. This applies to steel foundations. In wooden foundations careful measurements should be taken of the distance between the bottom of the engine supporting flanges and the top of the foundation. A continuous wooden shim should then be prepared and this shim should exactly fit the space between the foundation and the engine supporting flanges. The shims should be at least as wide as the supporting flanges.

After the engine is resting on the chocks or wooden shims it is advisable to check that the foundation is supporting the engine evenly over the entire length. This is best done with a #696 Starrett Strain Gage. Check the distance between the inside faces of the crankwebs with the corresponding crank on upper and lower centers. (See figure in Section F for strain gage location.) Readings for any one crank should not differ more than .003". Distortion of the last two cranks only indicates that the crankshaft is out of line with the propeller shafting. (When making this check the engine and propeller shaft couplings should be bolted together.) Check the last two cranks in the two horizontal positions also. If misalignment or uneven support is indicated determine the cause and correct.

When the final alignment has been accomplished permanent foundation bolts should be fitted. For steel foundations drill and ream for fitted bolts. Spaces between the foundation bolt chocks can then be filled with type metal.

Section C

3. SERVICE PIPING

Plan all piping carefully and use as short and direct lines as possible. To improve the general appearance of the installation, piping should be laid below the engine room floor when it is possible to do so. Removable floor plates should be provided and care should be taken that all piping is accessible.

4. FUEL AND LUBRICATING OIL PIPING

See Section N for pipe sizes and arrangement of the fuel day tank. See Section T for lubricating oil day tank connections. Pipe sizes are stated in these Sections. Provide drain valves and vent valves where necessary and remove all scale and dirt from pipes and fittings before installing.

5. COOLING WATER PIPING

Locate the sea chest far enough below the water line to prevent uncovering when the vessel rolls. It should be provided with a coarse grating. Inside the hull a strainer of ample size should be provided with gate valves on each side so that it can be isolated for cleaning. For engines equipped with centrifugal circulating water pumps it is particularly important that the resistance in the sea chest, strainer and piping be as small as possible. Use as few bends as possible and do not make either suction or discharge piping longer than necessary. Locate the overboard discharge not more than 3' above the water line. All valves should be gate valves - not globe valves. Use pipe sizes called for on the outline drawing.

6. STARTING AIR PIPING

Air tanks should conform to A.S.M.E. specifications and should have ample strength for 250 lbs. per square inch pressure. Each tank should be equipped with a safety valve and a globe valve for isolation. A drain valve should also be provided at the lowest point and this valve should be accessible.

Tanks should be connected to the engine starting air header using the pipe size called for on the outline drawing. Provide a globe valve next to the engine. All valves and fittings should be of heavy pattern for at least 250 lbs. per sq. inch pressure. The air compressor on the engine should be connected to the tanks with pipe of the size called for on the outline drawing and valves and fittings of heavy pattern. The air compressor discharge pipe should preferably be run to the air tank. It should not be connected to the piping between the tank and the starting air header. Air compressor unloader should preferably be connected to the tank with its own piping or tubing. Under no circumstances should it be connected to the compressor discharge line.

7. EXHAUST SYSTEM

All exhaust piping should be installed in the shortest and most direct manner possible. When bends are necessary use long sweep fittings. Use the pipe size called for on the outline drawing for lengths up to 20' containing a maximum of three bends. For 3 to 6 bends increase the pipe to the next nominal size and for each additional 30' length increase by one pipe size.

In order to protect the engine and piping from undue strains a length of flexible metal tubing should be installed as near to the engine as possible. It is also recommended that flanged connections be used for ease of dismantling and cleaning. For twin screw installations it is recommended that separate exhaust lines be used. If exhaust lines are combined and only one engine is running, soot and carbon will be blown into the other engine through the open exhaust valve.

OPERATING INSTRUCTIONS

Before the operator attempts to run the engine, he should carefully study the chapters dealing with the mechanical details, especially the governor. After familiarizing himself with the principles involved, the operator will understand the significance of the various movements of the control levers and will be able to handle the engine intelligently.

1. STARTING AIR LEVER

Observe the construction of the starting air lever, which is connected to the rocker shaft on one of the end cylinders. See Fig. D-1. The lever is held in the running position by a spring loaded latch which engages a notch in the quadrant. It may be moved to the starting position by pressing down on a pin in the handle.

The starting air rockers are mounted eccentrically on their fulcrum shafts. The ends of these shafts are connected together between the cylinders, so that the starting lever actuates all the shafts. When the shafts and lever are in the "Run" position the eccentrics are up, with the outer ends of the rockers raised. The lifters are then held up clear of the cams by springs. When the shafts are turned to the "Start" position the lifter rollers are pulled down into contact with the cams, which then actuate the starting air valves as the cam shaft rotates.

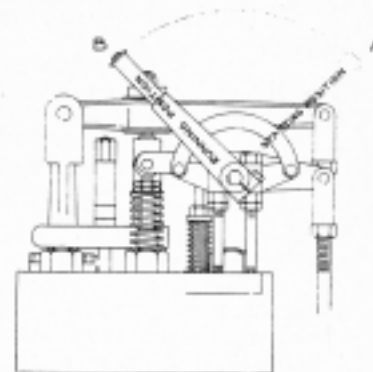

FIG. D-1

2. INITIAL STARTING AND STARTING AFTER PROLONGED SHUTDOWN

(a) A final check should be given all fuel, air, lubricating oil and water lines, giving attention to the location and position of shut-off valves, check valves, etc. It is well to trace each system through making sure that there are no short circuits or blockages.

(b) For the initial starting it is well, although not absolutely necessary, to fill the pressure lines and passages of the lubricating oil system. For this purpose a small hand operated gear pump or piston pump can be used. When the pressure lines are full, a slight pressure will register on the pressure gauge. This procedure will insure lubricating oil pressure immediately upon starting.

(c) Hand oil the engine at all the points listed under "4-HOUR ROUTINE" in the "Maintenance & Inspection" Section. Fill the mechanical lubricator and turn its crank several revolutions.

(d) In engines having less than six cylinders the starting position of the piston cycles do not overlap. In other words there are dead spots at certain points where no air starting valve is opened. When starting these engines it is therefore necessary to bar the engines over - always open the cylinder relief valves - to spot one of the pistons at a point slightly past top center on the power stroke. When on the power stroke both intake and exhaust valves are closed.

(e) Open the small vents on top of the outlet fittings of the high pressure fuel pump and operate the hand priming pump until fuel flows from both of these points. Then close these vents and pump up the fuel pressure to approximately 1500 lbs. per sq. inch by means of the priming pump handle on the high pressure fuel pump.

(f) See that valves in starting air piping between air receiver and engine are open and that there is sufficient air pressure available. (If the engine has previously been timed by means of fuel pressure or if it has been barred over it is good practice to close the spray valve isolating valves and open the compression release valves and then turn the engine over on air until any excess fuel in the combustion chambers has been blown out.)

(g) Set the governor control lever at the center of the sector.

(h) Disengage the propeller shaft clutch.

(i) Move the starting air handle to the start position. The engine will then turn over on air. As soon as firing commences, move the starting air handle back to the running position. Run the engine slowly at first and control the speed by means of the governor control lever. Adjust the fuel pressure to about 2000 to 2500 lbs. per sq. inch. Then immediately check and watch the following:

Section D

1. Lubricating oil pressure and circulation. Observe oil level in day tank or sump tank. Engine will absorb several gallons when started up.
2. Circulation of cooling water. Do not run the engine longer than 2 minutes or at high speed unless water circulation has started. In some instances priming of the water pump will be necessary but do not prime until the engine is cool.
3. Oil and water leakage from external lines and fittings.
4. Hot bearings. Feel covers at intervals to locate any hot areas which would indicate hot oil from a hot bearing.
5. Feel water jackets and manifolds for even water circulation.
6. Check the response of the fuel pressure relief valve by moving the handle up and down and watching the pressure gauge.
7. Listen to the engine for evenness of firing and mechanical knocks.

(j) The engine should then be gradually brought up to full speed. Increase the speed slowly and run at each new speed, checking the items under (i) at each increase. After running for a few minutes at full speed without load, reduce the speed to idling, engage the clutch and again slowly build up the speed, increasing the fuel pressure to 4000-4500 lbs. sq.in. as full speed is reached.

3. ROUTINE STARTING

Always check the positions of oil and water shut-off valves and make certain that no tools or the barring lever have been left where they can interfere with flywheel or shafting. Spot the engine in starting position. See (d) under Paragraph 2. After starting up check water circulation, lubricating oil level and pressure. The formation of a habit of checking these items automatically whenever the engine is started is likely to prevent accidents and serious damage. For routine starting it is only necessary to apply steps (d), (f), (g) and (i) in Paragraph 2 whereupon the fuel pressure can immediately be raised to 4000 lbs., and the engine brought up to full speed. The engine is usually started with the clutch disengaged, but if desired it may be started with the clutch engaged.

4. RUNNING

The following items should be watched and regulated if necessary:

(a) Oil Pressure. The lubricating oil pressure should be maintained between 30 lbs. per square inch and 45 lbs. per square inch.

(b) Cooling Water Temperature. For Seawater Cooling the outlet temperature should not exceed 125° F. If a Fresh Water Cooling System is used the outlet temperature may safely reach 150° F.

(c) Fuel Pressure. The fuel pressure should be varied with the engine load. At full load a pressure of around 4000 to 4500 lbs. per square inch will give the best results. However, as the load is reduced the fuel pressure should also be lowered to prevent too great a withdrawal of the wedges. Too high a fuel pressure at low speeds causes very short injection periods resulting in roughness and uneven engine operation. About 2000 to 2500 lbs. per sq. inch is suitable for idling.

(d) Mechanical Lubricator. The feed from the mechanical lubricator should be adjusted to 15 to 20 drops per minute per feed.

(e) Exhaust Temperature. The normal full load and speed exhaust temperature should not exceed the value stated in Section A. If the temperatures for all cylinders are above the stated value overload is at hand. If the exhaust temperature for any one cylinder is too high or too low the injection system is probably at fault. (See Section on "Smoky Exhaust" under "Maintenance & Inspection".)

(f) Exhaust Appearance. Observe the exhaust appearance. If it is smoky investigate the cause. In most cases the spray valves are responsible for smoke. (See section on "Smoky Exhaust" under "Maintenance & Inspection".)

5. TO STOP THE ENGINE

Turn the wedge shaft control lever located on top of the governor drive housing. This lever is connected by linkage to rotate the wedge shaft, pulling out the wedges and shutting off the fuel. The lever must be held in the stop position until the engine comes to rest. A latch release mechanism permits withdrawal of the wedges by means of the control lever without interference from the governor.

LOWER BASE, CRANKSHAFT AND BEARINGS1. BASE AND CRANKSHAFT

The cast iron base carries the main bearing saddles and the main lubricating oil manifold from which oil is piped to each main bearing. Short length of flexible metal tube provide the connection between the manifold and bearing saddles. The ends of the tubes are soldered into the manifold tees and leaded to the engine base. If replaced at any time the lead must under no circumstances project above the saddle bore. The crankshaft turns in babbitt lined steel backed bearing shells, held in place in the base by the main bearing caps. Adjustment is by shims, and running clearances should be .0008" to .00095" per inch of shaft diameter when bearings are fitted.

2. MAIN BEARING ADJUSTMENT

Bearing clearances can be accurately measured with two pieces of lead wire of about .025" diameter and one inch long, which are compressed between shell and journal about 1" from each end of the bearing by tightening the cap bolts. The thickness, measured with a micrometer, is the running clearance. Clearances should be checked annually, and should not be allowed to exceed .0015" per inch of shaft diameter. Keep shims even on both sides.

3. MAIN BEARING SHELLS

The bearing shells are prevented from rotating in the base by the shims, and are located fore and aft by a square head dovetail pin in the bottom of the bearing saddles which engages a circumferential groove around the outside of the shell. As fitted the shells project above the base and face of the caps from .002" to .003" on each side, but are squeezed down flush when the capnuts are pulled up. There should not be any appreciable clearance between the base, shim, and cap after final tightening. The bearing shells and caps are all numbered and must always be replaced in the bearing from which they were removed. Never interchange them, either from one bearing to another, or from top to bottom.

4. REMOVAL AND ASSEMBLY OF MAIN BEARINGS

After removing the cotter pins and main bearing nuts, the cap, upper shell and shims may be lifted out. As this operation is performed the positions of the numbers stamped on each of these parts should be noted so that the parts can be reassembled in their proper positions. Unless the bearing is considerably worn it may not be possible to remove the lower shell by hand and it is usually necessary to turn it out of the base by barring the engine over after inserting a capscrew in the oil hole in the journal. The head of the capscrew will contact the edge of the bearing shell and roll the bearing out with the journal.

When assembling the main bearing shells care must be taken to keep all parts absolutely clean. It is of utmost importance that any dirt be prevented from lodging between the shell and the saddle. Extreme care must be exercised in locating the bottom shell in a fore and aft direction before turning it into the base. Misalignment will cause the groove to miss the dowel pin in the base and trouble will then be encountered in backing the shell out again for another try.

5. CRANKSHAFT ALIGNMENT

The crankshaft should be checked at annual overhauls, or at intervals not greater than 7000 service hours, for misalignment due to uneven wear of the bearings. When the engine was erected at the factory the bearings were carefully scraped in, so as to bring the bearing surface of all shells in line. If one of these surfaces, due to uneven wear, becomes lower than the adjacent shells, it is evident that the crankshaft will be bent each time the adjacent cylinders fire and the connecting rods force the journal down against this low bearing. This condition must be guarded against, as neglect or ignorance of it will ultimately result in a broken shaft.

The simplest way to check crankshaft alignment is by means of a bridge gauge, which can be supplied with the engine as extra equipment. If a bridge gauge is desired it must, however, be ordered when the order for the engine is placed. It can not be supplied later.

With the bridge gauge straddling the journal and resting firmly and squarely on the bearing cap seats in the lower base the distance between the top of the main bearing journal and the machined face on the bridge gauge is measured by means of a feeler gauge. At the time the engine was erected these measurements were taken and were stamped on the bridge gauge. As the age of the engine increases the bearing sur-

Section F

faces will wear, with the result that these measurements will gradually increase. As long as they all increase by the same amount the shaft will still be in line however, and there need be no worry even though they do not agree with the original readings stamped on the bridge gauge. But if at any time the "wear down" or difference between the current readings and the original readings stamped on the gauge differs by more than $.004$ " between two adjacent bearings, the low shell should be replaced at once and the crankshaft re-aligned. This job should be undertaken only by an experienced mechanic. A careful record should be kept of all bridge gauge readings taken from time to time.

The bridge gauge measurements described above should be made successively, removing one bearing cap at a time and replacing it before proceeding to the next bearing. When making measurements the crankshaft journal must be forced down against the shell by means of a jack bearing against the centerframe. Protect the shaft journal with a piece of wood or sheet copper. An indication of low bearing shells will usually be given by looseness of the shell in the saddle. If it is possible to freely rotate one of the lower shells by hand when adjacent bearing caps are bolted down, it is quite probable that this shell is unduly worn and it should be checked with the bridge gauge at once.

If a bridge gauge is not available, crankshaft alignment may be checked with a gap or strain gage as follows: Stamp two center punch marks as shown in Fig. F-1 on all cranks. Starting with No. 1 cylinder crank remove adjacent main bearing caps and locate the crank as near lower center as gap gage will permit. Using jack screws between bearing journal and center frame force shaft against lower bearing half (protect shaft with a piece of wood or sheet copper) and record the gap gage reading. Then loosen jackscrews and bar over until crank is on upper dead center. Again tighten jack screws and record the gauge reading. Repeat on all other cranks.

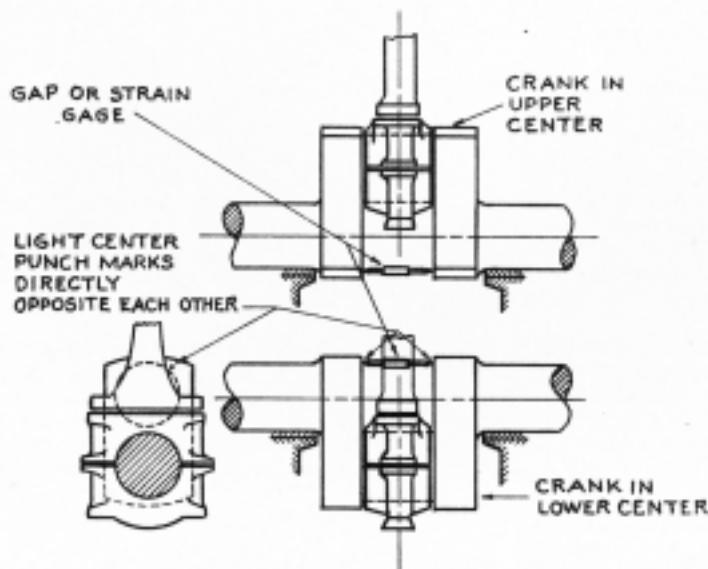

FIG. F-1

Comparison of gauge measurements in upper and lower centers will indicate crankshaft alignment conditions. Normally the measurements for the cranks in top position are slightly larger than measurements for the same cranks in the bottom position. However, the difference in measurement for any one crank should not exceed $.0005$ " per inch of shaft diameter. If this is the case, realignment of the crankshaft bearings is indicated.

CYLINDER AND LINER, CYLINDER HEAD AND VALVES1. CYLINDER

The individual cast iron cylinders are secured to the centerframe and base by four studs which are screwed into the base adjacent to the main bearing saddles. The cylinders are located transversely and are aligned to the centerframe by machined pads along one side which register with a step on the top of the centerframe. Crankcase sealer is used between the cylinders and the centerframe. If this joint is disturbed the old sealer must be scraped off and replaced by fresh sealer before tightening the cylinder nuts. Glyptal Lacquer is recommended for sealer.

On engines with 6½" to 8" bore the cylinder bore is machined directly in the cylinder casting, which is made of a special alloy iron, heat treated to relieve stresses and secure the correct hardness. A cored space between the cylinder barrel and the outside wall forms the cooling water jacket, pipe plugs in the outside wall providing access for inspection and cleaning.

2. CYLINDER LINER (Engines with 9" or larger bore)

On the larger engines replaceable cylinder liners are used, mounted in the cast iron cylinders. Hand hole covers in the cylinder wall provide access to the water jackets.

The cylinder liners are special alloy iron castings, heat treated to relieve stresses and secure correct hardness. They are accurately machined to close tolerances and should be handled carefully and care taken not to damage the fits at top and bottom. Spare liners should always be stored in a vertical position and should be securely fastened down if stored on board ship. The water seal at the bottom of the liner consists of two rubber grommets which should always be replaced with new ones whenever a liner is pulled. When lowering a liner into place, grease the grommets freely with cup grease and use care to enter the grommets into the cylinder fit or they may be pinched and damaged. The liner has from .003" to .005" clearance in the cylinder at both top and bottom fits and no difficulty should be encountered in installing a new liner. A paper gasket .010" thick is used for the upper water seal between the liner and cylinder and a new gasket should always be used when replacing a liner. The fits and shoulders on both liner and cylinder should be carefully scraped and wiped clean to assure a water tight joint. Care must be taken not to damage these shoulders, as a water leak will result.

A copper gasket, 1/32" thick, forms the gas seal between the liner and the head. The gasket and both sealing surfaces must be carefully wiped free of all dirt when assembling.

3. CYLINDER HEAD

The individual cast iron cylinder heads are carefully designed to assure uniform cooling. On the smaller engines pipe plugs provide access to the head jackets, and cover plates are used on the larger engines.

The cylinder head is centered by means of a spigot which engages the bore at the top of the cylinder or liner. The face of this spigot bears upon the copper gasket forming the gas seal. In the larger engines in which cylinder liners are used, brass bushings screwed into the cylinder and extending up into the head carry the cooling water. They are sealed by rubber grommets. Passover pipes, connecting parts in cylinder and head make the connection in the smaller engines.

When a cylinder head is removed it should be placed on wooden blocks, never on concrete floor or steel deck. The rubber grommets should always be replaced by new ones and all dirt should be wiped from the bottom of the head before it is lowered onto the cylinder.

4. INLET AND EXHAUST VALVES

Two types of intake and exhaust valves are used on Atlas Imperial Diesel engines. One may be termed one-piece forged type and the other two-piece cast head type.

The two-piece cast head type consists of a valve head cast of special heat resisting alloy iron and a steel stem which is screwed and riveted to the head. Inlet and exhaust valves of the two-piece construction are interchangeable and the same valve may be used for either intake or exhaust.

On engines where valves of the one-piece forged type are used the exhaust valves are of a special heat resistant alloy steel and may be distinguished from the inlet

Section H

valves by the "EXH." and "INL." stamped on the valve heads. The inlet valves are forged of chrome nickel steel and are not suitable for exhaust valves. The one piece valves should never be used interchangeably except in an emergency.

The ends of the valve stems are threaded for retaining nuts which secure the valve springs in place. The valves seat directly in the cylinder head castings and the stems work in renewable guides pressed into the heads. If the guides are replaced they should be pressed in the same distances as the ones originally in the head and should be reamed after pressing in place. Use a standard reamer which produces a hole with a diameter to size or .0005" oversize. For example the valve stem diameter on the 6 $\frac{1}{2}$ " bore engine is 5/8" and a standard 5/8" reamer should be used which should then ream the hole to .6250" - .6255" diameter.

When grinding valves always finish the grinding with fine compound, and take particular care not to get any grinding compound into the guide. Thoroughly clean all traces of the grinding compound from valve and seat before reassembling.

Lubricate valve stem with clean engine oil before placing in guide. If valve faces are badly pitted they should be refaced in a lathe, as excessive grinding to remove pits will wear down the seats unnecessarily and will also cut a groove in the valve face. Badly pitted seats should also be refaced before grinding. Care must be taken to keep the seat concentric and square with the bore of the guide.

5. STARTING AIR VALVES

The starting air valve is guided in the head by a bushing which is clamped to the valve stem and works freely in the head. Two piston rings form the air seal between bushing and head. A nut on the stem secures the bushing and a spacer to the stem and also serves as retaining nut for the spring. The lower end of the spring is supported by a washer, bearing against the cylinder head. The starting air rocker is mounted eccentrically on the rocker shaft. The rocker shafts are connected between the cylinder heads, forming one complete shaft, and when the engine is to be started the entire shaft is rotated by means of a hand lever on one end, the eccentrics bringing the push rod lifters down into engagement with the cams. When the engine is running the push rods are held up free of the cams by springs.

PISTON AND CONNECTING ROD1. PISTON

The pistons which are of the one-piece, solid-skirt type are made of high grade cast iron and are heat treated to relieve stresses and to obtain proper hardness. The piston is ground straight, that is without taper, from the bottom up to the ring belt. The clearance in the liner is .001" per inch of bore diameter. Due to manufacturing tolerances the total clearance of the piston skirt may vary .001" up or down from the above value. For example: the piston skirt clearance in a 13" bore engine should be between .012" and .014". The head of the piston being exposed to high temperatures is given a larger clearance, approximately .0055" to .006" per inch of bore diameter.

2. PISTON PIN

The case hardened and ground piston pin is stepped, with differential fits in the piston pin bosses. The fits are about .0005" to .0015" press on the small end and metal to metal to .0015" loose on the large end. Rotation of the pin in the piston is prevented by the engagement of a dowel which projects radially from the large end of the pin with a groove in the bottom of the boss. A setscrew threaded into the smaller pin boss enters an indentation in the pin to act as a retainer. The setscrew is in turn secured by a locknut.

3. PISTON RINGS

Six piston rings are used per piston, an oil ring above and below the piston pin and four compression rings. Always assemble the oil rings with the bevel up, to slide over the oil film on the upstroke and scrape it down on the return. When overhauling pistons, thoroughly clean all carbon from rings and grooves and top of piston. Fuel deposit on the piston skirt can best be dissolved with cleaning solvent or paint remover. Be sure oil drain holes below oil rings are open.

Check rings for side clearance in grooves and end clearance, as measured in place in the liner. Side clearance should be .003" to .005" with new pistons and rings and end or gap clearance .005" per inch of bore diameter for the two top rings. For the other rings the gap clearance should be .003" per inch of bore diameter.

Rings should be discarded when the side clearance exceeds .008" and the end clearance .007" to .008" per inch of bore diameter. It is also a good policy to discard any rings which have been stuck for any length of time as they are apt to be out of round and may not hold compression. Always check new rings, measuring the side clearance, in the groove in which the ring is to run, with feeler gauge, and the end clearance with the ring in the liner at the smallest diameter. Never install rings with less clearance than that given above. As the oil rings wear the width of the flat increases, with consequent decrease in width of bevel and oil scraping ability. Experience will determine permissible wear without excessive oil pumping.

4. CONNECTING ROD

The connecting rods are steel forgings, rifle drilled to carry oil to the piston pins. Shims between foot of rod and crankpin box provide adjustment to balance compression pressures in the cylinders to the desired value. The distance "X" (see

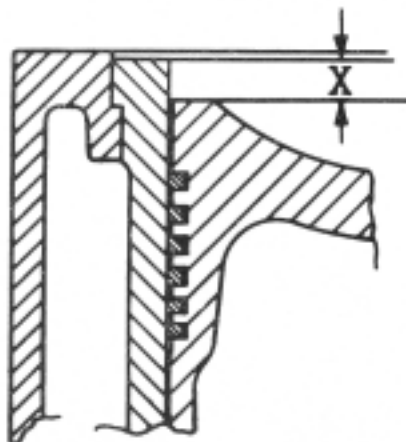

FIG. K-1

Fig. K-1), between the top of the piston and the top of the liner should be in accordance with the tabulation below. If liners are not used, dimension X should be measured from the extreme top face of the cylinder, not from the recess for the copper gasket.

Engine Bore and Stroke	Dimension "X"
6½ x 8½	13/16
7½ x 10½	31/32
8 x 10½	31/32
9 x 12	3/4

When taking measurement "X" the piston should be at top dead center and the cylinder liner must be securely clamped down into the cylinder. The cylinder stud nuts must also be tight when making this adjustment. Connecting rod shim adjustment in accordance with the above tabulation should be used for altitudes from sea-level to 1500' and will then produce compression pressures of 400 to 410 pounds per square inch. If the engine is located at higher altitudes than 1500 feet above

Section K

sea-level dimension "X" should be smaller than the tabulated values. The Engineering Department of Atlas Imperial Diesel Engine Co. will advise the proper adjustment if the engine serial number and altitude is stated.

A bronze bushing for the piston pin is pressed in the upper end of the rod. If this bushing is replaced it must be reamed to allow a piston pin clearance of .0015" to .0025" on 6½" to 8" bore engines and .0020" to .0035" on engines with 9" bore. Care must be taken to keep the reamed hole exactly parallel with the foot of the rod. The oil grooving in the bushing is carefully designed for correct lubrication, and new bushings must be inserted in rod with the relief grooves on the horizontal axis of the pin. A ball check valve at the bottom of the rod prevents return of the column of oil in the rod. Examine these valves at annual overhauls. The ball lift should not exceed 3/32".

5. CONNECTING ROD BEARINGS

The crankpin boxes are steel castings with babbitt lining centrifugally cast and accurately bored. No attempt should be made to rebabbitt these boxes in the field. New boxes may be obtained from A.I.D.E. Co. and a credit allowance will be made for old boxes returned. Bearing adjustment is by means of shims between halves of bearing. Bearing clearances when adjusted should be .0008" to .0009" per inch of bearing diameter.

Clearances are best measured with a lead wire compressed between bearing and journal, as described in Section F. Keep the shim thickness equal on the two sides. Inspect the bearing surfaces for even bearing. Areas which are not bearing on the shaft will be discolored, and such bearings as well as new ones should be carefully scraped to secure even bearing over at least 3/4 of the entire area. End clearance is .007" to .015" and should not be allowed to exceed .025".

6. CONNECTING ROD BOLTS

The connecting rod bolts, fitting in reamed holes, hold the two halves of the crankpin boxes together and to the foot of the rod. The nuts should be kept pulled up tightly but not overstressed. They should not be sledged but should be pulled up by hand with a pipe about four feet long on the wrench. It is good practice to keep a record of the length of connecting rod bolts, measured with a micrometer at annual overhauls and to discard bolts that show more than .010" increase in length. It is further recommended that all connecting rod bolts be replaced every two years, assuming the engine to have had continuous service during that time, say 8000 hours or more. It is nearly always old bolts that have been in service for some time and have been overstressed by pulling up the nuts too tightly that fail. Replacing bolts as suggested above is cheap insurance against the possibility of wrecking an engine through connecting rod bolt failure. Replace cotter pins carefully, always using new cotter pins. Be sure that they are a close fit in the hole and bend the ends back tightly against the sides of the nut. If this work is left to inexperienced mechanics it should be very carefully inspected at the completion of the job. Always replace rods, bearings and pistons in the cylinders from which they were removed. All parts are numbered.

1. CAMSHAFT

The camshaft is made of ground steel shafting, $1\frac{1}{2}$ " dia. for the $6\frac{1}{2}$ " bore engines and 2" dia. for the $7\frac{1}{2}$ " and larger bore engines. The keyways in the shaft are indexed for the firing sequence stamped on the engine nameplate. The high pressure fuel pump crankshaft is part of the camshaft assembly and is bolted to a coupling flange which has been shrunk on and keyed to the end of the camshaft.

2. CAMSHAFT BEARINGS

The camshaft bearings are accurately machined cast iron blocks with pressed in bronze bushings. Bearing bore in bushing is reamed to allow a running clearance of .002" - .004" on $6\frac{1}{2}$ " bore engines and .004" - .006" on $7\frac{1}{2}$ " and larger bore engines. If replaced the bushings must be reamed and oil and mounting holes drilled through after pressing in. A groove must be chipped to communicate with the oil hole if it does not intersect the groove in the bushing. The bearing blocks are held in machined seats cut in the webs of the centerframe and are secured by capscrews.

The camshaft thrust is taken by the bearing on the gear end. The camshaft gear hub and the lubricator eccentric which is pressed on the end of the shaft against a shoulder, bear against alternate ends of the bronze bearing. (On the 9" bore engines a thrust washer is inserted between the gear hub and bearing.) The gear hub is clamped to the shaft and should be located to allow .015" to .025" thrust clearance. Both this bearing and the bearing on the opposite end of the camshaft are supplied with oil from the pressure lubricating oil system. The intermediate bearings are lubricated from reservoirs in the top of the bearings, filled by splash from the connecting rods. Drilled holes in the end of the camshaft and in the fuel pump crankshaft feed oil to the fuel pump connecting rods from the after camshaft bearing.

3. CAMS

The cams are accurately ground to shape after being case hardened. The fuel valve cam consists of a case hardened steel disc which is bolted to the after end of the exhaust cam hub. A case hardened steel toe is inserted and this toe controls the action of the spray valve, the disc serving as a base circle. On $6\frac{1}{2}$ ", $7\frac{1}{2}$ " and 9" bore right hand engines, and on $6\frac{1}{2}$ " bore left hand engines, the inlet and air starting cams are machined on opposite ends of a common hub. On $7\frac{1}{2}$ " and 9" bore left hand engines, however, the air starting cams are separate pieces, bolted to the ends of hubs formed by the exhaust cams. The Cam sequence, progressing toward the Fuel Pump End of the Engine is as follows:-

Right Hand	$6\frac{1}{2}$ x $8\frac{1}{2}$	Engines -- Exhaust - Fuel - Air Starting - Inlet
Left Hand	$6\frac{1}{2}$ x $8\frac{1}{2}$	Engines -- Inlet - Air Starting - Fuel - Exhaust
Right Hand	$7\frac{1}{2}$ -8 x $10\frac{1}{2}$	Engines -- Exhaust - Fuel - Air Starting - Inlet
Left Hand	$7\frac{1}{2}$ -8 x $10\frac{1}{2}$	Engines -- Inlet - Fuel - Air Starting - Exhaust
Right Hand	9 x 12	Engines -- Exhaust - Fuel - Air Starting - Inlet
Left Hand	9 x 12	Engines -- Inlet - Fuel - Air Starting - Exhaust

See Section "A" Engine Data for explanation of Right and Left Hand Engines.

The cams are a sliding or light tap fit on the camshaft and are held in place by taper keys, driven home after the cams have been lined up with the lifter rollers.

4. CAMSHAFT REMOVAL

- (a) Remove centerframe covers, including housings for rotary pump drive and governor drive.
- (b) Disconnect bilge pump connecting rod and remove high pressure fuel pump connecting rods.
- (c) Remove push rods and valve lifters. (Lifters and guides may be left in place if lifters are raised clear of cams and clamped in place)
- (d) Remove camshaft bearing retaining screws.
- (e) Loosen the cylinder nuts on the camshaft side of the engine.
- (f) Remove the camshaft. Sledge each bearing block out of its seat a little at a time using a timber inserted through the openings on the exhaust manifold side. The end of the timber should be placed against the camshaft as close to the bearing as possible. When the camshaft has been partially removed it will be possible to withdraw the connecting rods and crossheads of the fuel pump downward.

5. CAMSHAFT DISASSEMBLY

After the camshaft has been removed from the engine it should be disassembled as follows. The lubricator eccentric is removed either by a suitable puller or by driving with a babbitt hammer. Then, after removing the first bearing the clamping bolts of the camshaft gear hub are loosened and the whole assembly slid off. Bear-

Section L

ings and cams are then removed successively from the gear end of the camshaft. FOR ALL RIGHT HAND ENGINES THE CAMS ARE LOOSEMED BY DRIVING THE KEYS WITH A DRIFT TOWARD THE GOVERNOR END OF THE ENGINE. FOR LEFT HAND ENGINES WITH 6½" BORE THE CAMS ARE LOOSEMED BY DRIVING THE KEYS TOWARD THE FUEL PUMP END OF THE ENGINE, AND FOR LEFT HAND 7½" AND 9" BORE ENGINES THE KEYS ARE DRIVEN AWAY FROM THE CYLINDER CENTER LINES. THAT IS, THE INLET CAM KEYS ARE DRIVEN TOWARD THE GOVERNOR END OF THE ENGINE AND THE EXHAUST CAM KEYS TOWARD THE FUEL PUMP END. The cams should slide freely on the shaft after the keys have been removed, but if it should be necessary to drive them off, only a babbitt hammer or brass drift should be used. Any burrs, particularly at keyways, must be dressed down with a file. If this precaution is not taken the cams may seize as they are removed, and forcing the cams the remainder of the distance will score the shaft.

6. CAMSHAFT ASSEMBLY & INSTALLATION

When the camshaft is being reassembled the same precautions with regard to burrs apply. Coating the bores of the cams with white lead will aid materially in sliding the cams into place without scratching the shaft. The bores of either new or old cams should be inspected carefully for any defects likely to scratch the shaft. Bearings and cams are installed successively from the after end but are not keyed to the shaft until later. The hub and cam gear are assembled on the shaft and clamped tightly. The camshaft gear should be located to allow .015" to .025" end clearance for the thrust bearing.

The assembled camshaft is then installed in the engine. After starting each cam bearing in its seat the bearings are driven into place a little at a time with a heavy brass bar. Each bearing should be driven a little and then left until all the others have been knocked in the same amount so that the camshaft will not be bent. The cam bearings will seat more easily if the cylinder nuts are loose.

The connecting rods and crossheads of the high pressure fuel pump must be assembled as the camshaft is being driven into place. The crossheads should be inserted in the holes in the centerframes before the camshaft has been driven in any appreciable distance. When the camshaft has been partially installed it will be possible to place the connecting rods on their respective cranks. After this last step the connecting rods and crossheads need no further attention as the cam bearings are being seated.

After the cam bearings have been securely bolted the cams are ready for keying. Starting with Number 1 (governor end) cylinder place each set of cams directly under the proper lifter rollers and secure the cams to the shaft by inserting the taper keys. Drive the keys IN THE OPPOSITE DIRECTION from that given in Paragraph 5 under CAM SHAFT DISASSEMBLY. Always insert the keys in the cams so that the driving is against the large end of the key. Complete this procedure with each set of cams before going on to the next and work aft from the forward end of the engine.

The engine should next be timed, in accordance with the detailed instructions in Paragraphs 14 to 16 after which the rotary pump and governor assemblies may be re-assembled on engine. For Fuel Spray Valve timing see Section O.

7. VALVE LIFTERS

The steel valve lifters work in cast iron guides bolted to the top of the centerframe and carry case hardened rollers on steel pins on their lower ends. Clearance between lifters and guides is .0015" to .0025", between rollers and pins is .001" to .0025". Roller pins are a light press fit in the valve lifters. After roller pins have been assembled the hole in the lifter should be peened over with a 3/16" wide drift at top and bottom to secure the pin. Dress down the outside diameter with a file if necessary in order to secure a sliding fit in the lifter guide.

8. PUSH RODS

The push rods for the inlet, exhaust and starting air valves are steel rods. The lower ends fit into sockets in the lifters and the upper ends are threaded into the rocker forks. Drilled holes through the rods permit inserting a drift to hold the rod when adjusting the forks, and jam nuts lock the adjustment. On the 6½" bore engine sockets are used on the upper ends of the rods instead of forks, bearing against ball studs which are inserted in the ends of the rockers. The fuel push rods are fabricated of seamless steel tubing with steel ends welded into place.

The steel pins which link the forks to the rockers on the 7½" and larger bore engines have -.0005" to +.0027" clearance in the forks and .000" to .0025" clearance in the rocker ends. The pins are retained by ball checks which are pressed into the rocker ends and which engage circumferential grooves at the centers of the pins. The pins may be removed by tapping with a hammer and drift.

9. VALVE ROCKERS

The rockers for the inlet, exhaust and starting air valves are fulcrumed on a shaft which is supported by bearings at each end. The bearings are mounted on studs screwed into the cylinder heads and are held between nuts on the studs. By screwing the nuts up or down the rocker shaft can be raised or lowered.

The three rockers are bronze bushed at their fulcrums and the bushings are reamed for .001" to .003" clearance with the rocker shaft after pressing in. On 7½" and larger bore engines case hardened rollers at the valve end of the exhaust, inlet and air starting rockers work directly on the valve stems and turn on steel pins riveted in the rocker forks. The clearance of the rollers on the pins is .0005" to .0015". On 6½" bore engines case hardened steel buttons are used instead of the rollers.

The fuel valve rocker is not carried on the shaft with the other three rockers. A support located on the manifold side of the cylinder head acts as a fulcrum. The steel fulcrum pin, retained by cotter pins at each end, has a clearance of .000" to .0017" in both pieces.

10. VALVE TIMING

The correct valve timing for the engine is given in the following table.

Starting Air Valve Opens - - - - -	50°	B.T.C.
" " " Closes - - - - -	45°	B.B.C.
Inlet Valve Opens - - - - -	10°	B.T.C.
" " Closes - - - - -	35°	A.B.C.
Exhaust Valve Opens - - - - -	35°	B.B.C.
" " Closes - - - - -	5°	A.T.C.
Fuel Spray Valve Opens - - - - -	see engine name plate	
" " Closes - - - - -	see engine name plate	

11. SPOTTING THE PISTON

Before proceeding with the discussion on valve timing the following instructions regarding the correct method of spotting a piston should be considered. Whenever a piston is to be spotted for valve setting it should be brought into position by turning the engine in the direction of rotation in order to take up all gear backlash. If the engine is turned past the desired position, it should be turned well back in the opposite direction, and then again brought up to the required point.

12. FLYWHEEL MARKINGS

The position of the piston may be determined from the flywheel pointer and the markings stamped on the flywheel rim. Top center of each piston is marked and stamped with the corresponding piston numbers, and degree marks are stamped on each side of top center.

13. POINTER LOCATION

The location of the flywheel pointer should be checked occasionally by "splitting the center". With one of the cylinder heads removed, crank the engine to a point about 20° off top center. Measure the exact distance from the top of the liner down to the piston and observe the pointer reading on the flywheel. Then set the piston to the same distance below the top of the liner on the other side of top center and observe the flywheel pointer reading. If the readings do not agree adjust the pointer to give equal readings on each side. These readings should preferably be taken with an indicator and in each case the piston should be cranked upward into position.

14. CAMSHAFT TIMING

In order to time the engine it is necessary to determine the correct relation between the crankshaft and camshaft. This is done by positioning the camshaft gear on its hub, and then adjusting the push rods to open and close the valves at the correct points. Unless the crankshaft gear, camshaft gear or camshaft gear hub have been replaced, the camshaft can be correctly timed after overhauling as follows. Before breaking the gear train spot No. 1 piston exactly on firing top center. With a steel scale bearing firmly against the machined side of the centerframe scribe a line across the side of the camshaft gear parallel to the centerframe face. When reassembling, mesh the gears with the crankshaft and camshaft in the same relative positions, that is, with No. 1 piston on firing top center and the line on the camshaft gear in line with the centerframe face.

Section L

If the crankshaft gear, camshaft gear or the camshaft gear hub is replaced, the camshaft may be timed as follows:

- (a) Spot No. 1 piston $2\frac{1}{2}^{\circ}$ B.T.C.
- (b) Set the camshaft gear relative to its hub so that clamping bolts are approximately in the center of the slots. Orient camshaft gear so that old dowel holes will not interfere with redowelling.
- (c) Turn the camshaft (with intermediate gear out of mesh) so that the inlet and exhaust lifters of No. 1 cylinder are each raised an equal distance. (NOTE: The piston was set at $2\frac{1}{2}^{\circ}$ B.T.C. as this is the mean position between the 10° B.T.C., opening of the inlet valve, and the 5° A.T.C., closing of the exhaust valve, and at this position both valves should be open an equal distance.)
- (d) Holding crankshaft and camshaft in above positions and allowing camshaft gear to slip on its hub as required, mesh the intermediate gear and tighten the clamp bolts between the camshaft gear and hub. After all valves have been timed and checked, drill $\frac{31}{64}$ " holes through gear in line with dowel holes in hub and ream to $.497$ " - $.498$ " for dowels. On $6\frac{1}{2}$ " bore engines use $\frac{23}{64}$ drill and ream $.372$ " - $.373$ ".

After determining the correct relation between the camshaft and crankshaft the push rods must be adjusted as follows: (See Section O for timing of fuel spray valve.)

15. INLET & EXHAUST VALVE TIMING

- (a) Spot piston at 10° B.T.C. at the end of the exhaust stroke.
- (b) Adjust inlet push rod so that valve is just opening.
- (c) Spot piston at 5° A.T.C. on the suction stroke.
- (d) Adjust exhaust pushrod so that valve is just closing.
- (e) Check clearance between valve stems and rocker rollers. The cams are designed for $\frac{1}{32}$ " clearance with the valves set as above and with the engine cold, but this will vary somewhat due to manufacturing tolerances. When making the adjustments aim at the opening and closing points but keep the clearances between $.020$ " and $.040$ ", varying the opening and closing points slightly if necessary. Excessive clearances mean a noisy engine and increased wear on parts. Insufficient clearances prevent valves from seating properly, with consequent blowby and destruction of valves and seats.
- (f) Check and record closing point of inlet valve and opening point of exhaust valve. These points should fall within 5° of the position given in the timing table.
- (g) Adjust and record inlet and exhaust valves for the other cylinders as above.

16. STARTING AIR VALVE TIMING

- (a) Block the valve rocker shaft in its starting position (handle against the stop).
- (b) Spot piston at 5° B.T.C. at the end of the compression stroke and adjust the pushrod so that the valve is just opening. Check the closing point, which should fall within 5° of the position given in the table. (See Paragraph 10) On $7\frac{1}{2}$ " and larger bore left hand engines the air starting cam is a separate piece, bolted to the end of the inlet cam hub. Before making the push rod adjustment clamp the two cams together, indexing them with the clamp bolts approximately at the centers of the elongated holes in the air starting cam.
- (c) Adjust and record starting air valves for the other cylinders as above.

17. CAMSHAFT GEARING

The camshaft is driven from a gear on the crankshaft by means of an intermediate gear. The crankshaft gear is shrunk on the shaft adjacent to the forward crank web. If replaced the new gear should be heated to approximately 600° F. and slipped over the shaft. On $6\frac{1}{2}$ " bore engines use a temporary spacer to locate the gear $\frac{1}{4}$ " from the crank web. On $7\frac{1}{2}$ " and 9 " bore engines locate the gear against the shoulder on the shaft. Do not overheat the gear, as this will damage the steel structure, and once it is started on the shaft move it immediately to the final position, as it will be impossible to move it further once it begins to cool and seize the shaft.

The intermediate gear has replaceable bronze bushings and rotates on a case hardened steel shaft. The intermediate gear bracket in which the shaft is mounted is bolted and doweled to the centerframe cover on the governor end of the engine. It is adjusted before doweled to allow $.006$ " - $.008$ " gear backlash. If replaced the intermediate gear bushings should be reamed to 1.5000 " - 1.5005 " dia. after pressing in, which allows $.002$ " - $.004$ " running clearance. The bearing is lubricated by oil from the pressure pump.

FUEL SUPPLY SYSTEM

The complete fuel system may be conveniently divided into two parts, the fuel supply system and the fuel injection system. The fuel supply system is made up of the fuel transfer pump, the fuel day tank and the fuel filter, while the fuel injection system includes the high pressure fuel pumps, the fuel rail, the accumulator, the fuel pressure regulating valve, the fuel spray valves, and the necessary connecting tubing.

1. IMPORTANCE OF CLEANLINESS IN FUEL HANDLING

The high pressure fuel pumps and fuel spray valves have been referred to as the heart of the Diesel engine and the proper functioning of these parts is necessary for the successful operation of the engine. These pumps depend upon lapped plungers working in cylinders with clearances measured in hundred thousandths of an inch and it is vital that the fuel entering these parts be kept free of any grit or foreign matter. The engine is equipped with filters for this purpose but it is also necessary for the operators to use every possible care in getting clean fuel oil and in keeping it clean until it is delivered to the engine. Fuel tanks and piping should be thoroughly cleaned when installed and should be kept covered at all times.

The fuel filter should be periodically cleaned and serviced according to the detail instructions given in Paragraph 3. The best filters obtainable will be useless if dirt is introduced into the fuel after it has passed through them, and it is therefore of great importance that every effort be made to protect the fuel pipes after the filter during repairs and overhauls. Cleanliness in handling fuel, piping and injection equipment is of vital importance and will pay good dividends in trouble-free operation. Many times mysterious and expensive pump and fuel spray valve troubles have been traced to careless handling of fuel and carelessness in storing and installing spare parts.

2. FUEL TRANSFER PUMP

The gear type fuel transfer pump, together with the lubricating oil sump and pressure pumps, is mounted on one of the centerframe doors. It supplies fuel under pressure to the day tank and high pressure fuel pump, sucking from the fuel service tank. The three pumps are grouped together into one unit, gear driven from the camshaft. The drive is described in Section T under Lubricating Oil System. The fuel transfer pump is clamped in a saddle on the centerframe door, assuring correct alignment of the shaft. The packing gland should not be kept tighter than necessary, allowing a very slight leakage for lubrication of the shaft.

3. FUEL OIL DAY TANK & FILTER

The fuel oil day tank and filter are shown in Fig. N-1. A continuous flow of fuel oil from the fuel transfer pump enters the unfiltered fuel compartment (4) through tube (1). Metal edge type fuel filter (2) is mounted in the side of tank (6). It has .003" spacing and is provided with a cleaning knife (3), operated by

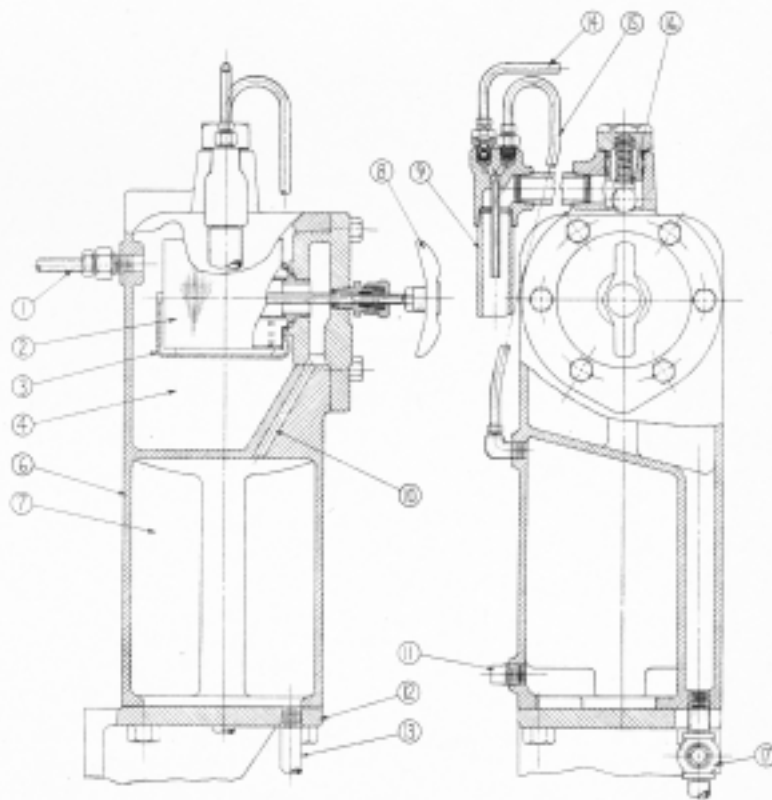

FIG. N-1

Section N

handle (8), which scrapes the dirt and muck off the outside of the cleaning spool. The handle should be turned every four or five hours, and should always be turned immediately after stopping the engine, as the dirt can then settle freely through the quiescent fuel. The dirt and sediment collects in the sludge compartment at the bottom of the tank, and should be drained off through cock (17) at frequent intervals. This may be done to advantage when the engine is running, the pressure in compartment (4) assuring thorough cleaning.

After passing the filter the fuel flows through hole (10) into the clean fuel compartment (7), and then to the high pressure fuel pump through pipe (13). This pipe is screwed into mounting bracket (12) which forms the bottom of the tank. Compartment (7) can be drained by removing plug (11). The excess fuel from the transfer pump passes through relief valve (16) and returns to the service tank through overflow pipe (9). The relief valve maintains a pressure of 6 lbs. per sq. in. in the filtered fuel compartment. When the high pressure system of the engine is being primed air is admitted to compartment (7) through tubes (14) and (15) allowing the fuel to flow to the priming pump. The check valve in tube (14) permits sucking air when priming and prevents escape of fuel oil when the engine is in operation. When the engine starts the air in compartment (7) escapes through tube (15). The pressure in filtered fuel compartment (7) assures a continual flow of fuel through tube (15) into the overflow pipe, with no possibilities of reverse flow of unfiltered fuel from the overflow pipe to compartment (7).

FUEL INJECTION SYSTEM1. HIGH PRESSURE FUEL PUMP

The high pressure fuel pump is located on top of the centerframe on the operating side. The pump consists of one or two plungers actuated by cross heads and connecting rods from a crankshaft which is bolted to the end of the camshaft. One or two plungers are used depending on the engine bore and the number of cylinders. All engines with 6-1/2" bore have high pressure pumps equipped with one pump plunger which is also used on all 3-Cyl. models with bores up to and including 9 inches. 4 and 6-Cyl. models of engines with 7-1/2" or larger bores are equipped with two plunger pumps such as shown on Fig. O-1. The construction of the high pressure pumps with one and two plungers are however similar and the following description applies to either model. Both single and two plunger high pressure pump units are equipped with one hand operated plunger which is used for priming the fuel system and for building up fuel pressure when the spray valves are being timed or tested.

Referring to Fig. O-1 cast iron guides (4) are located in holes in the centerframe and are secured by capscrews. Cross heads (6) work in these guides and are actuated by the crankshaft and connecting rods (19). The bronze connecting rods have a clearance of .0015" to .003" on their crankpins and a side play of .005" to .009". The cross head pin bearing is formed directly in the upper end of the connecting rod and the pins have a clearance of .001" to .002" in the cross heads and in the connecting rods. Each cross head has a replaceable bronze sleeve (3), held in place by a shoulder on the lower end of the cross head and by oil guard (2) and plug (1) at the upper end. The clearance between the sleeve and the cross head guide is .002" to .004" and if it should become excessive new sleeves should be installed. Lubrication is by spray from the cranks.

Pump housing (31) and top cover (8) are both secured to the centerframe by means of through bolts (10). Top cover (8) carries the individual pump bodies (9) to which pump barrels (16) are secured. One of the pump bodies also carries the hand operated priming pump. Pump barrel (16) is threaded into the pump body and is seated at the upper end. A copper gasket (11) at this end provides a fuel tight seal. Spring

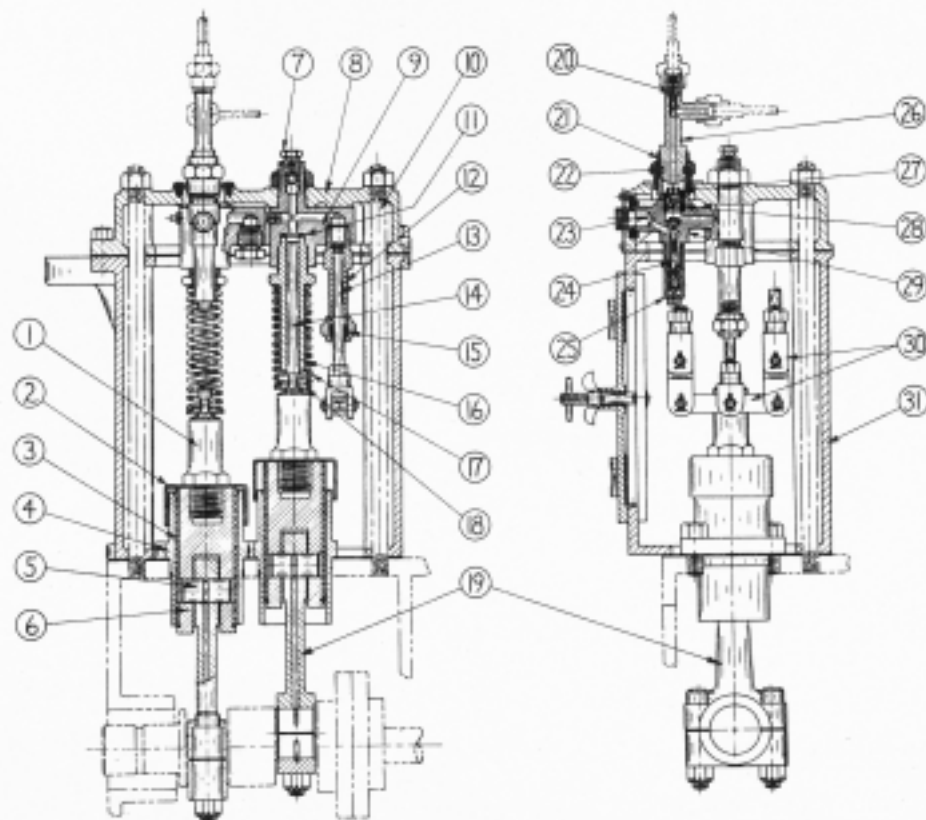

FIG. O-1

Section O

(17) is retained at the lower end of plunger (14) by washer (18) and forces the plunger downward on the suction stroke. The plungers and barrels are lapped together in matched pairs and are not interchangeable. In other words a plunger must always be used with the particular barrel to which it was lapped. If either piece becomes scored or damaged both must be replaced. Always wash parts thoroughly in clean solvent or fuel oil and lubricate with clean engine oil before replacing.

The suction and discharge valves are contained in housing (29) which in turn is screwed into pump body (9). Fuel under slight head from the filter and day tank unit is supplied through port (23). The fuel is discharged on top through discharge fitting (26) which is provided with two discharge connections, one being connected to the fuel rail and accumulator and the other to the fuel pressure regulating valve. In the case of high pressure pumps with two plungers the top outlet of one pump is connected to the side outlet of the second pump. On both single and two pump units a second discharge valve (20) is provided at the top discharge connection leading to the rail and accumulator. The seat and guide for suction valve (24) is formed in cage (29). The suction valve spring is enclosed by bonnet (25) which also prevents fuel leakage at that end. A flat is provided on the suction valve guide, connecting the bonnet space with the fuel supply. Discharge valve seat (28) is hardened and is pressed into cage (29). The discharge valve lift is limited by the lower end of fitting (26).

Both the suction and discharge valves may be removed and serviced by unscrewing nut (21) holding the discharge fitting to the valve cage by means of split collar (22). If the valves are leaky lapping the seats lightly with fine grinding compound is recommended but if this is not successful new valves and cage assembly should be installed. If the lower end of discharge fitting above the discharge valve shows signs of heavy hammering this is usually due to discharge valve seat (28) being loose in the cage. The cage and seat must then be replaced.

Priming pump barrel (12) is threaded into pump housing (9) and priming pump plunger (13) is actuated by linkage from the vertical priming lever on the pump housing top cover. Packing and nut (15) prevents leakage past the plunger. The upper end of the plunger is formed as a valve head which engages a seat in the barrel, preventing leakage when the priming pump is not in use. If the pump leaks while the engine is running the plunger valve head should be lapped in. If leakage takes place when the fuel system is being primed, packing (15) should be either tightened or replaced. When priming the fuel system loosen plug (7) which will allow air in the pump to escape. Tighten the plug when solid fuel appears.

Fuel leakage from the pumps and the priming pump collects on top of the centerframes inside the pump housing and is drained off through a hole in the end of the centerframes. The high pressure fuel pump has been designed to give long trouble-free performance, but it must be given reasonable care. Water, dirt and other impurities in the fuel will materially shorten the life of the plungers and barrels. The normal working pressure is 3000 to 4500 pounds per square inch but the pump is capable of building up pressures far in excess of these figures. It is consequently important that the fuel pressure regulating valve is functioning properly so that excessive pressures are not built up which may injure the pumps and may also damage other parts of the injection system.

2. FUEL RAIL

The fuel rail is located on the operating side of the engine level with the tops of the cylinder heads. One end of the rail is connected directly to the high pressure fuel pump and the other end is connected to the accumulator, pressure relief valve, pressure gauge and back to the high pressure fuel pump.

Isolating valves are built into the fuel rail at the outlets to the spray valves and an additional valve is provided for the purpose of testing the spray valves.

The fuel rail consists of a length of 3/4" O.D. x 3/8" I.D. seamless steel tubing inserted in and brazed to the bodies of the isolating valves. The isolating valve stems, which have hardened conical ends, are threaded into the valve bodies. The valve seats are replaceable tobin bronze washers and are held in place by plugs which are screwed into the valve bodies and to which the injection lines from the spray valve are connected.

3. INJECTION TUBING

All of the high pressure lines used in the injection system are seamless steel tubing. The ends are formed by brazing union sleeves to the tubing, and union nuts fasten these ends to the various fittings. 1/4" O.D. x .065" wall thickness tubing is used between the fuel rail and the spray valves and from the accumulator to the fuel pressure gauge. A high grade tubing is used, made especially for this service,

and standard seamless steel tubing should never be substituted.

The importance of keeping the injection lines clean cannot be overemphasized. When an injection line is removed from the engine the open ends should be covered with clean paper which should not be removed until the tubing is to be placed on the engine again. If there is any doubt as to the cleanliness of an injection line it should be thoroughly cleaned before installing. To clean a line it should be washed repeatedly in cleaning solvent or gasoline and should be blown out with an air hose between each washing. This cleaning process should be carried on until there is no uncertainty as to the cleanliness of the tubing.

4. ACCUMULATOR

To prevent large pressure fluctuations in the injection system each time a spray valve opens or a pump delivers fuel the volume of the system is increased by the addition of an accumulator. The fuel in the accumulator, due to its compressibility, tends to maintain a constant pressure in the fuel system without appreciable fluctuations. The accumulator is a welded steel bottle mounted on top of the centerframe and is connected to the fuel rail.

5. FUEL PRESSURE REGULATING VALVE

Injection pressure control is afforded by the adjustable pressure relief valve. This valve is of the by-pass type in which the opposing forces of a spring and the fuel pressure acting on the stem of a needle valve maintain constant fuel pressures. If the pressure starts to drop the spring closes the needle slightly reducing the amount of fuel by-passed with the result that the pressure is held constant.

Referring to Fig. O-2 the regulating valve is built around valve body (7). The hardened steel valve seat (8) is held between the body and adapter stud (9) which screws on the bottom of the body and through which passage (18) allows the by-passed fuel to escape. Fuel inlet elbow (16) is threaded into the side of the body, supplying fuel to the annular space around the reduced section of the valve stem (17). The top of the body is bored to receive stem packing (15) and packing gland (14). Screwed to the top of the body is relief valve spring cage (5). This cage is screwed down upon the drain cup holding the latter in place against a shoulder on the body.

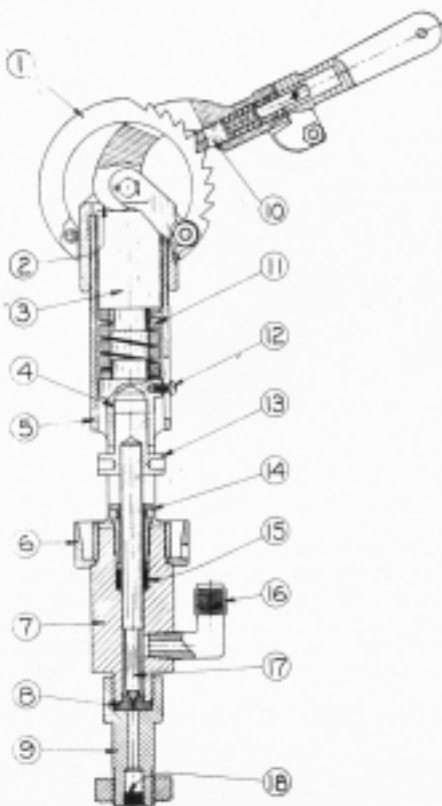

FIG. O-2

Cage (5) carries upper spring seat (3), Spring (11), and the lower spring seat. Valve spring adjusting screw (13) which is bored to receive the upper end of the valve is threaded into the bottom of the lower spring seat. A small machine screw in the lower spring seat engages a slot in the cage and prevents rotation of the seat when the adjusting screw is being turned. The bearing assembly which holds the control handle and sector (1) is threaded to the upper end of cage (5). The lower part of the control handle is shaped to form a cam which actuates the upper spring seat. A spring loaded pawl (10) in the handle engages teeth in sector (1) so that the handle will remain in position after it has been adjusted. A downward force on the end of the handle pulls the pawl away from the sector and allows the handle to be lowered.

The injection pressure is normally changed by moving the handle up or down. Moving the handle in an upward direction increases the pressure, downward movement lowers the pressure. The pressure increase or decrease per notch is approximately 600 to 800 lbs. However, the pressure in any notch may be changed by means of adjusting screw (13).

Packing (15) will need replacing when the fuel leakage around the valve stem (17) becomes excessive. Tighten the packing gland just enough to prevent leakage. Never attempt to stop leakage by tightening the gland severely when new packing is needed. A loss of fuel pressure can often be traced to dirt lodged between valve stem (17) and the seat (8). This condition can be remedied by removing adapter stud (9) and valve seat (8) from

the bottom of the relief valve and thoroughly cleaning the valve and its seat. Occasionally it may be necessary to lap the needle and its seat to prevent excessive by-passing and a low fuel pressure. After performing this operation all traces of grinding compound should be carefully washed off before the valve is reassembled.

6. SPRAY VALVES

The purpose of the spray valve (or fuel injection valve) is to meter the fuel accurately, to deliver it precisely at a definite moment, in a definite time into the combustion chamber in the form of a finely atomized spray. It might be stated that the successful operation of the engine depends upon the proper functioning of the spray valves more than on any other item. If the engine does not perform properly and the exhaust is smoky, the functioning of the fuel valves should be checked first of all. In the great majority of cases servicing the fuel valves and making them function properly corrects the trouble.

Fundamentally, the spray valve is a heavily spring loaded needle valve. Referring to Fig. 0-3 the seat of the needle valve is incorporated in the tip or nozzle (1) just above the entrances to the spray orifices. The lower end of valve body (4) is counterbored to receive the end of the spray valve tip. A shoulder on the spray tip (1) which is centered in the counterbore, is held securely against the lower end of the body by nut (2). Valve assembly (3) is made up of two sections. The lower section has a conical end which is ground to the seat in the spray valve tip. This lower stem section is pressed into an extension (10) to which the spring loading is applied and by which the stem is lifted. A shoulder on the extension carries a small ball type thrust bearing (14) which acts as a lower spring retainer. Upper spring retainer (12) screws into the upper end of valve spring casing (13) which in turn is threaded to the upper end of valve body (4).

The flange used for clamping the valve is drilled and tapped to receive fuel elbow (6) which supports the small metal edge type filter (15). Fuel is carried from this point to the nozzle in the annular space surrounding stem (3). Leakage upward along the stem is prevented by packing (7) held between an upper and lower gland and secured by packing nut (8).

7. REMOVAL OF SPRAY VALVE FROM ENGINE (See Fig. 0-3)

- (a) Remove the cotter pin from one end of pin (37) at the fulcrum end of spray valve rocker (36). Drive the pin out with a brass drift.
- (b) Remove horseshoe shaped collar (16) which forms the link between the rocker and the upper end of the spray valve and swing the rocker out of the way.
- (c) Disconnect the injection line at the spray valve filter.
- (d) Loosen the clamp nut and slide spray valve clamp (11) out of position.
- (e) Remove the spray valve from the engine. It may be necessary to work the valve loose by rotating it back and forth and in some cases to pry it upward with a bar to remove it. As the valve is removed, note whether copper gasket (5) remains in the cylinder head or on the end of the valve.

8. TEST EQUIPMENT

All the parts for a spray valve test stand are included in the tool equipment supplied with the engine. The spray test clamp which holds the spray valve directly below the flanged section of the body can be mounted on the centerframe of the engine or at some other convenient location near the engine. The long stud supplied with this equipment screws into the outer end of the clamp. The test handle is supported on the upper end of the stud by a nut which can be screwed up or down on the stud until the desired height of fulcrum has been obtained. Fuel is supplied from the extra fuel rail valve through a length of tubing supplied with the tool equipment. Fuel pressure is obtained by means of the hand operated priming pump located at the forward end of the high pressure fuel pump. To test a spray valve proceed as follows:

- (a) Clamp the spray valve in the test stand and connect it to the fuel rail.
- (b) Close all the isolating valves on the fuel rail and open the valve which supplies the test stand.
- (c) With the priming pump build up a pressure of about 2000 to 4000 lbs. per square inch.
- (d) Open the valve quickly three or four times by hitting the end of the test handle

sharp blows with the fist, watching as the valve operates to see if a fine fuel spray comes out of each hole in the tip.

(e) Wipe off the tip carefully, pump up the pressure to about 4000 lbs. per square inch again and operate the spray valve as described in step 4 until the pressure has dropped to about 2000 lbs. per square inch. Then watch the bottom of the tip for a period of time to see if drops of fuel form, indicating tip leakage.

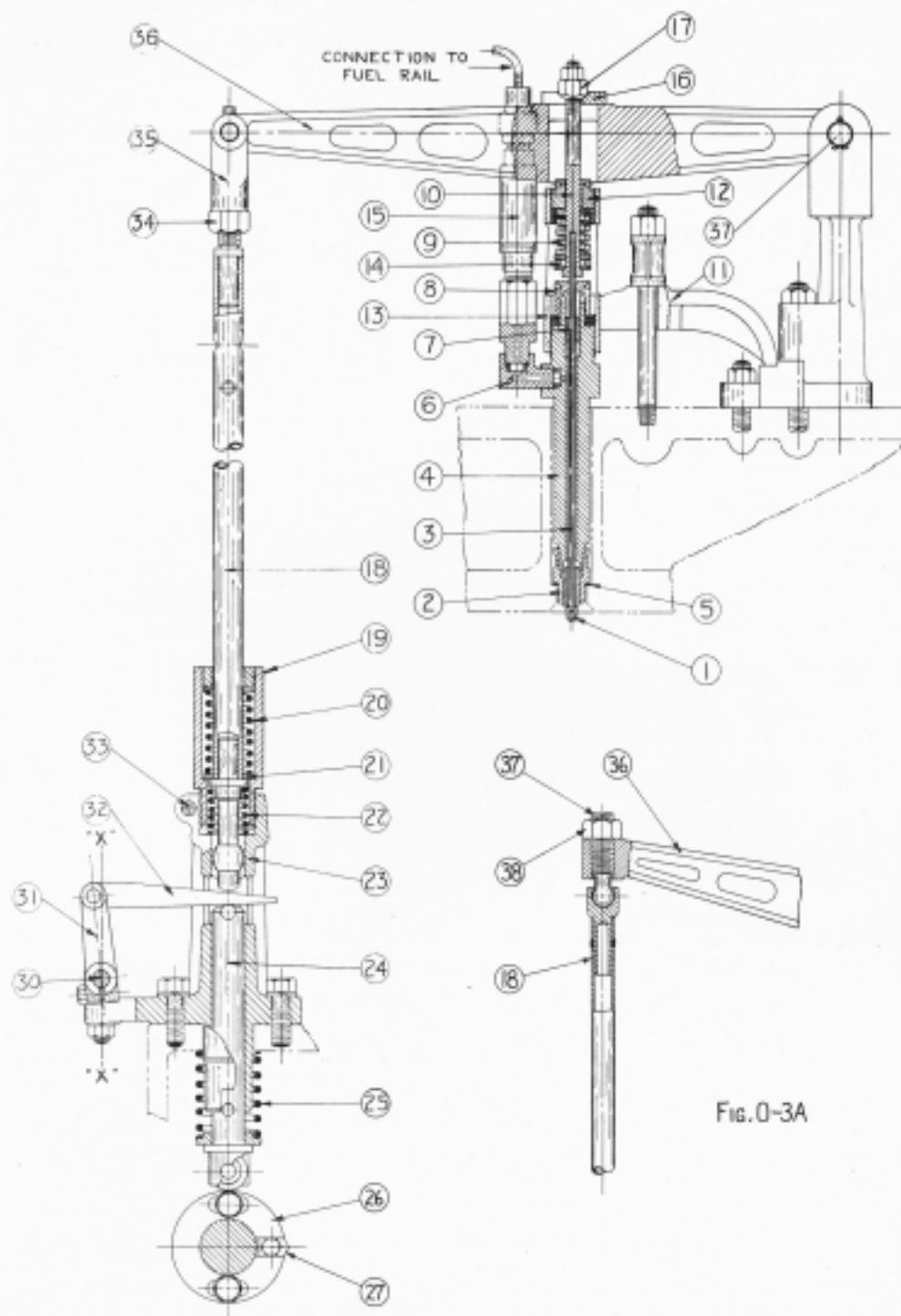

FIG. O-3A

Section O

9. DISASSEMBLY OF SPRAY VALVE (See Fig. O-3)

If the sprays are not uniform, if one or more orifices are entirely plugged up, or if drops of fuel form on the end of the tip after testing as described in step (e) of the preceding section, the spray valve must be taken apart and serviced. Proceed as follows:

- (a) Clamp the spray valve at the flanged section of the body in a vise.
- (b) Unscrew upper spring retainer (12) with a suitable pin or drift.
- (c) Loosen packing nut (8) and remove stem assembly (3 and 10) together with the retainer (12), spring (9) and thrust bearing (14).
- (d) Unscrew valve seat nut (2). Spray tip (1) will usually come off with the nut.
- (e) Drive the tip out of the nut with the punch supplied for this purpose in the tool equipment. Use care not to damage end of tip.
- (f) Clean the outer surface of the tip with a wire brush dipping the tip into cleaning solvent or fuel oil frequently during the brushing.

10. CLEANING THE SPRAY ORIFICES

If the sprays are not uniform or an orifice is plugged up the holes in the spray tip must be cleaned. Again, if it is necessary to disassemble the spray valve for some other reason such as leakage, it is good practice to clean the orifices at the same time. It sometimes happens that all of the orifices become slightly clogged with the result that they deliver less fuel. Such a condition cannot be detected when the spray valve is tested but if the holes are cleaned every time service work is performed upon the spray valves this condition will be taken care of.

The cleaning of the orifices should be performed only with the music wire and pin vise supplied with the tool equipment, not with the ends of hat pins and other such devices. If the original wire is lost obtain a piece of music wire of not more than .007" dia. for this purpose. (On engines with 9" bore a wire diameter of .009" may be used.) Work the wire in and out of each orifice until the holes are clean. This operation should be performed carefully so that the orifice will not be deformed.

11. CORRECTING SPRAY VALVE TIP LEAKAGE

Leakage of the spray valve is usually due to a small amount of dirt between the needle and the valve seat. Often this condition can be remedied by washing the tip thoroughly and cleaning the end of the valve stem. This procedure should be attempted first in all cases of valve leakage.

If, after washing the tip and spindle, drops of fuel still form on the bottom of the tip shortly after the fuel valve is sprayed, it will be necessary to reseat the valve by lapping. The procedure of reseating a tip is as follows:

- (a) Clamp the valve body in a vise horizontally.
- (b) Loosen spring retainer (12).
- (c) Apply a small amount of fine valve grinding compound to the end of valve stem (3).
- (d) Place the tip over the valve stem and insert it fully into the valve body.
- (e) Adjust retainer (12) so that the stem exerts a light pressure on the tip.
- (f) Oscillate the tip back and forth and rotate the spindle slowly. Be sure that the tip is held against the body as this operation is being performed so that the tip will be properly guided.
- (g) Repeat steps "c", "d", and "f" if necessary.

It should not be necessary to lap the tip more than two or three times to correct ordinary cases of leakage. However, if the seat in the tip has been badly damaged no amount of lapping will remedy the situation. In such instances a new tip should be installed. When installing a new tip the joint between the tip and the valve body must first be lapped. A small amount of fine valve grinding compound is applied to the upper face on the shoulder of tip (1). The tip is then installed in the end of the valve body and oscillated back and forth. The tip is held gently against the body as this operation is being performed. One light lapping process should be sufficient to produce a perfect seal between the tip and valve body. The tip is then lapped to the valve stem by the method described in this paragraph.

12. VALVE PACKING ADJUSTMENT

Packing nut (8) should never be appreciably more than finger-tight. A small amount

of fuel leakage past the packing is necessary for proper lubrication of the spindle. Too tightly adjusted packing will prevent this lubrication and will result in a scored spindle and sluggish valve action. If a spray valve leaks excessively along the spindle after the packing has been lightly tightened up the need for new packing or a new spindle or both is indicated.

13. ASSEMBLY OF THE SPRAY VALVE - SPRAY VALVE "LIFT"

Referring to Fig. O-3, spring (9) must be adjusted to a certain tension in order to assure proper functioning of the spray valve. It is further important that the adjustment of all the spray valve springs be the same or that the "lift" on all the spray valves be the same. With "lift" as used in the following instructions is understood the lift which spring (9) will allow before its coils touch each other and prevent further upward movement of the valve stem. (The actual lift when the spray valves are operating in the engine is of course determined by the position of fuel wedge (32), the adjustment on pushrod (18) and cam (27). This actual lift is less than the "lift" as defined in this paragraph.) Proceed as follows to assemble the valve and adjust for proper "Lift" (or opening tension):

- (a) Wet spindle (3) with clean fuel oil and slip it into position in the valve body.
- (b) Clean the spray valve tip and install it carefully on the valve body. Tighten valve seat nut (2) securely.
- (c) Screw down on spring retainer (12) carefully until the coils of spring (9) just touch. Be careful not to screw down so hard that valve stem (3) bends, rendering it useless. It is best to have the valve in the test stand when performing this operation and determine when spring (9) becomes solid by means of the test handle. When it is not possible to lift the spray valve stem by means of the test handle the spring coils are touching. The "Lift" is then zero.
- (d) Unscrew spring retainer (12) $3/4$ to $7/8$ turns which will make the "lift" $1/16$ ". The "lift" on all the valves should be between $1/16$ " and $5/64$ ".
- (e) Screw down on packing nut (8) until it is just finger-tight.
- (f) Test the functioning of the valve as described in paragraph 8.

14. ASSEMBLY OF SPRAY VALVE IN ENGINE

The spray valve is installed in the engine in the reverse order of its removal. Again referring to Fig. O-3, if copper gasket (5) is in the cylinder head merely lower the valve into position. If the copper gasket (5) was removed with the valve, the gasket can be held in position on the lower end of the valve by a thin coating of grease applied to the washer.

After installing the valve it will be necessary to reset the push rod as described in paragraph 18. After timing, in order to clear the cylinder of excess oil, always turn the engine over on air with the snifter valves open and with the fuel isolating valves closed.

15. SPRAY VALVE FUEL FILTERS

In addition to the fuel filter at the high pressure fuel pump an individual filter (15) is supplied at each spray valve. The spray valve filters are of the metal edge type and have a spacing of .0015". They are installed in housing (15) which screw into the fuel inlet elbows at the spray valves. The frequency at which these filters will need cleaning will depend upon the quality of the fuel and the condition of the filter located at the high pressure fuel pump. After disassembling the housings it will be possible to unscrew the filter unit. Wash each unit thoroughly in clean solvent or fuel and blow it clean with compressed air, being careful not to injure the windings when handling it.

16. SPRAY VALVE OPERATING MECHANISM (See Fig. O-3)

The spray valve is actuated by cam (27), lifter or cam follower (24), pushrod (18), and rocker arm (36). Lifter (24) and latch (29) are held against the cam by spring (25). Motion of the lifter is transmitted to the pushrod through wedge (32). As can readily be seen in Fig. O-3, moving the wedge inward will decrease the gap between the lifter and the pushrod. Consequently the spray valve will open sooner, will lift higher, and will close later. Moving the wedge outward produces the opposite results. The outer end of the wedge is pinned to lever (31) which is clamped to the wedge shaft, which in turn is connected to the governor. Accordingly the governor, by rotating the wedge shaft, completely controls the action of the spray valves.

When the engine was tested at the factory, wedge levers (31) were adjusted to be parallel to each other and in line on wedge shaft (30) and were then clamped and

Section O

pinned to the shaft. If new levers or a new wedge shaft are installed it is important that they be lined up in accordance with the above. The position of the fulcrum of wedges (32) for the full load full speed position (wedges fully in) should be about 1/4" inside the vertical line X-X through the center of the wedge shaft. The position of the wedge fulcrum for idling at low speed should be as shown in Fig. 11, that is, about 1/4" outside line X-X. In other words, line X-X should approximately divide the total movement of the wedge fulcrum in two equal parts.

Lever (35) should be approximately parallel for all the spray valves. This is accomplished by means of adjusting nut (17) which bears down on horseshoe collar (16) which in turn bears down on lever (36). With the lever disconnected from push rod fork (35) hold it up against collar (16) and nut (17) without opening the spray valve. Then adjust nut (17) for the proper lever position and lock by means of the lock nut on top.

Buffer spring assembly (19), positions the pushrod relative to the lifter and assists spray valve spring (9) in returning the valve mechanism (rocker, pushrod, etc.) as the spray valve is being closed. The weak spring (22) below buffer spring (20) merely holds the pushrod against washer (21). As buffer spring assembly (19) is screwed down buffer spring (20) and washer (21) force the pushrod downward against the weaker spring and bring the end of the pushrod closer to the wedge and lifter. Proper adjustment of the buffer spring assembly is as follows:

- (a) Bar the engine until the fuel cam follower is on the base circle of the cam.
- (b) Set the wedge shaft and wedges in full load position (wedges "fully in" as determined by the governor weights being fully in) and unscrew cage (19) until there is clearance between the lower end of the pushrod and the upper face of the wedge.
- (c) Slowly screw down cage (19) and at the same time move the wedge back and forth sideways with fingers.
- (d) As soon as the wedge is felt to tighten unscrew the cage one-half turn and lock it in this position with the clamping screw.

NOTE: When timing the spray valves as described in the following the buffer spring assembly should always be unscrewed about one or two turns. When timing is completed adjust the buffer spring in accordance with instructions in this paragraph.

17. SPRAY VALVE TIMING (See Fig. O-3)

The timing procedure described in the following is for a spray valve opening of 8° B.T.C. (Before Top Center) and a spray valve closing of 18° A.T.C. (After Top Center). The proper spray valve timing to use is stamped in the engine name plate and should always be followed. If the timing in the name plate differs from 8° - 18° opening and closing the following instructions should be modified accordingly. Proceed as follows:

- (a) Shift the camshaft to the AHEAD position and unscrew all Buffer Spring Cages one or two turns. Shut off all the isolating valves in the fuel rail except for Number 1 cylinder.
- (b) Be sure that wedges are in the full load position ("fully in") as determined by the governor weights being against their inner stops. (Normally the wedges will be "fully in" when the engine is shut down but it is well to check this point.)
- (c) Spot Number 1 cylinder at 5° A.T.C. on the power stroke. (Half way point between 8° B.T.C. opening point and 18° A.T.C. closing point.) Then unbolt and turn the fuel cam until the center of the toe is directly in line with the axis of the lifter. Clamp the fuel cam temporarily.
- (d) Set the crankshaft 8° B.T.C. on the compression stroke. Bar the engine up to this point in the ahead direction of rotation.
- (e) Pump up a fuel pressure of about 1500 lbs. per sq. inch with the hand pump.
- (f) Slowly lengthen the spray valve pushrod until the needle of the pressure gauge drops indicating that the spray valve has opened. Check this adjustment by backing the engine up a few degrees, pumping the fuel pressure up again and barring the engine slowly in the ahead direction until the pressure again drops. If the flywheel pointer is not at 8° B.T.C. readjust the pushrod and check again.

To adjust the length of pushrod (18) loosen locknut (34) and turn the pushrod, using a pin or drift in the holes provided at its upper end. Then tighten the

locknut. On 6-1/2" bore engines the pushrod length is not changed. Referring to Fig. O-3A ball stud (37) in rocker (36) is screwed up or down instead. To adjust loosen locknut (38) and turn ball stud (37) with a screw driver. Tighten locknut (38) after the adjustment has been accomplished.

- (g) Bar the engine over to 25° A.T.C. and again pump up the fuel pressure. Then bar the engine backwards slowly until the pressure drops. This point, which is the closing of the spray valve, should be 18° A.T.C.
- (h) If this point is past 18° A.T.C. too long a spray period is at hand. It will be necessary to advance the fuel cam slightly and repeat steps "d", "e", "f", and "g". If on the other hand the spray valve closes before 18° A.T.C., retard the cam slightly and repeat steps "d", "e", "f", and "g".
- (i) Repeat steps "c" to "g" on the remaining cylinders. Check and record the spray valve timings for ASTERN. The timing going Astern may be slightly different than the ahead timing. However, the ahead timing is the more important and no changes should be made to favor the astern timing.
- (j) Adjust the buffer springs as per instructions in paragraph 16. Note that buffer spring cages should always be unscrewed when spray valves are timed.

18. BALANCING THE ENGINE FOR EQUAL LOAD ON ALL CYLINDERS

Theoretically, if the spray valves have been timed exactly and correctly (as outlined in the preceding paragraph) the amount of fuel injected in each cylinder should be the same. Consequently, the total engine load should also be equally divided between all the cylinders. Practically however, it is impossible to time all the spray valves exactly alike, and even if that could be accomplished manufacturing tolerances on such items as orifices in the spray valve tips, fuel cams, wedges, etc. are apt to affect the cylinder balance. The division of load between the various cylinders should consequently be checked after the engine is running, preferably at full load. Since the exhaust temperatures are proportional to the loads that the various cylinders are carrying the amount of fuel injected should be adjusted so that the exhaust temperatures for the various cylinders are alike, or nearly alike.

The amount of fuel injected and consequently the load carrying capacity of a cylinder may be changed by adjusting the length of pushrod (18), or in the case of 6-1/2" bore engines, by adjusting ball stud (37). (See Figures O-3 and O-3A respectively) It should be noted, however, that readjusting will affect the spray valve timing. Therefore, the adjustment should not be appreciable and should not exceed one-half turn of the pushrod or ball stud from the position obtained when timing the spray valve.

The proper procedure for balancing the engine can be summarized as follows:

- (a) Assuming that all the spray valves have been correctly timed to open at 8° B.T.C. and close at 18° A.T.C. it should be possible to balance the engine by merely lengthening or shortening the pushrods by one-half turn or less. In the case of 6-1/2" bore engines the rocker adjusting screw should not be turned more than one-half turn. Lengthening a pushrod or screwing down on the rocker adjusting screw will increase the exhaust temperature of the cylinder and vice versa.
- (b) If an adjustment of one-half turn is not sufficient the timing of all the spray valves should be checked and, if necessary, adjusted for an opening of 8° B.T.C. and a closing of 18° A.T.C. for full load wedge shaft position as described in Paragraph 16.
- (c) If the valve timing is found to be satisfactory or if, after making any necessary correction in the spray valve timing, a correction of one-half turn of the pushrod is still insufficient, defective combustion is indicated. This may be due to one or more spray tip orifices being plugged or to any of the defects dealt with under the heading "Smoky Exhaust" in the "Maintenance and Inspection" section.

When the engine was tested at the factory spray valves were carefully timed and adjusted to equalize the exhaust temperatures in the various cylinders and while the operator should not continually change adjustments in an effort to improve an engine that is operating satisfactorily he should keep the balance of the various cylinders fairly even. The cylinder balance should be checked whenever a spray valve has been changed. If the exhaust temperatures are kept within a total range of 20° the balance will be excellent, while a range of 50° may not be considered excessive and will give fairly satisfactory operation. However, do not allow the cylinder unbalance to exceed the last mentioned value.

GOVERNOR1. GOVERNOR

The flyball type governor is mounted on the forward end of the centerframe and is driven by the camshaft gear. It is illustrated in Fig. Q-1. Governor housing (21) which forms the governor bearing is bolted and doveled to the centerframe. It is located to allow .004" - .005" backlash between governor gear (22), which is keyed and pressed on governor body (20), and the camshaft gear. Lubricating oil from the pressure pump is piped to the bearing through a drilled hole in the housing. Governor weights (23) are mounted on fulcrum pins in governor body (20) and carry hardened steel rollers (24) on riveted pins. As the flyballs tend to move out due to centrifugal force, the rollers bear against thrust plate (12) and transmit the force developed by the weights through quill rod (11), thrust bearing (17) and spring block (14) to governor spring (3). The thrust reaction is taken by bearing (19), which is secured to the governor body by threaded retaining collar (18). Thrust clearance is adjusted to .010" and the collar is locked by a set screw, secured in place by a locking wire through the head.

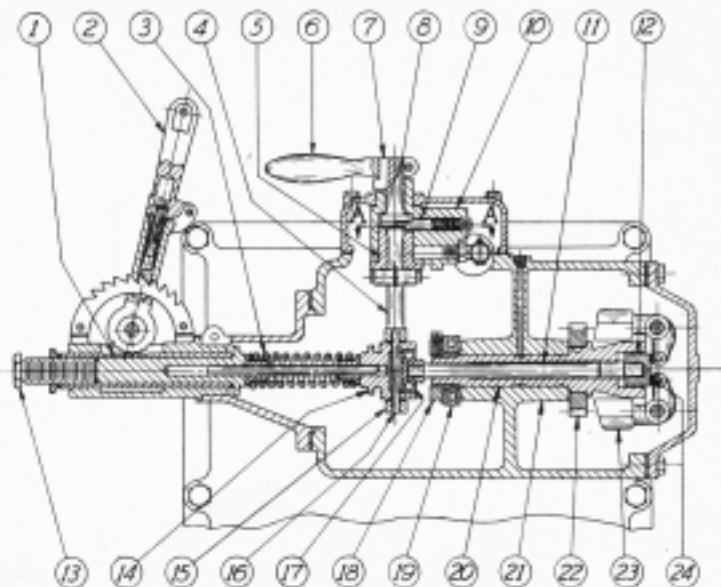

FIG. Q-1

Spring block (14) follows the motion of the weights resulting from variations in engine speed. This motion is further transmitted by means of pin (16) and fork (15) to vertical shaft (4), to which fork (15) is clamped. Additional linkage connects vertical shaft (4) to the fuel wedge shaft to which each of the wedges are linked, thus completing the connection from the governor weights to the fuel wedges. The engine speed is controlled by varying the tension of the governor spring through hand lever (2) and rack (1). The lever is held in place by a latch which engages a toothed quadrant. A break mechanism in the handle permits moving the lever to the left, which reduces the spring tension. This allows the governor weights to move out, withdrawing the fuel wedges and reducing the engine speed. Conversely moving the control lever to the right increases the engine speed. Adjusting screw (13) controls the engine speed and should be set to give the desired full load speed (see engine name plate) with the governor control lever in the last notch. The engine will then idle at the proper speed with the control handle in the first notch. The adjustment is secured by means of a lock nut.

2. STOPPING MECHANISM

The engine is stopped by rotating the hand lever on top of the governor housing. Lever (6) (See Fig. Q-1) is connected through a release mechanism to floating lever (10) on top of vertical shaft (4). Lever (10) is linked directly to the fuel wedge shaft. The release mechanism is shown in detail in Fig. Q-2 which is an enlarged section taken through A-A in Fig. Q-1. It serves to break the connection between Lever (10) and vertical shaft (4), releasing the wedge shaft from governor control. Referring to Fig. Q-2 it will be noted that set screw (25) and plunger (9), both of which are mounted in lever (10), form a rigid connection between levers (10) and (5). Lever

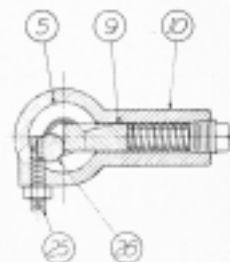

FIG. Q-2

Section Q

(5) is clamped to vertical shaft (4) and appears in Fig. Q-2 as the annular segment, the opposite ends of which bear against the diagonally milled flat on the lower side of plunger (9) (shown dotted in Fig. Q-2) and the end of setscrew (25). This is the normal position of the mechanism when the engine is running, levers (10) and (5) operating as a single unit. When hand lever (6) is pulled to stop the engine, eccentric (26) on the lower end of shaft (8) engages the end of plunger (9) and forces it back against its spring, out of engagement with lever (5). Lever (10) is then free to rotate counterclockwise without interference with lever (5). As control lever (6) is moved further the projecting key (7) engages a boss extending from the top of lever (10) (not shown in Fig. Q-1) and thereafter lever (10) follows the motion of hand lever (6), pulling out the fuel wedges and stopping the engine.

REVERSE GEAR AND THRUST BEARING1. GENERAL

Five different size reverse gears are used on the various Atlas Reverse Gear Marine Engines, in accordance with the following table.

NO. OF CYLS.	BORE & STROKE	REVERSE GEAR SIZE	ILLUSTRATION
2-3-4	6½ x 8½	14"	Fig. S-1
3 & 4	7½ x 10½	19"	Fig. S-3
3 & 4	8 x 10½	19"	Fig. S-3
3	9 x 12	19"	Fig. S-3
4	9 x 12	21"	Fig. S-3
3	10 x 13	21"	Fig. S-3
4	10 x 13	24"	Fig. S-4
4	10½ x 13	24"	Fig. S-4
3 & 4	11½ x 15	28"	Fig. S-4
3 & 4	13 x 16	28"	Fig. S-4

The gear is made up of a planetary transmission, a disc clutch, and two brakes, operating on the drum of the transmission and on the propeller shaft. The resulting drive permits complete control of the propeller shaft by means of the clutch control mechanism. Its operation is described under Paragraph 6. The reverse gear is closely associated with the thrust bearing, and both units are shown in the illustrations and included in the following description. The different size gears are quite similar in design and the description applies to all of them with the exception of certain differences that are mentioned in the text. Fig. S-1 and Fig. S-2 show longitudinal and transverse sections through the 14" gear, Fig. S-3 illustrates the design of the 19" and 21" gears and Fig. S-4 the 24" and 28" gears. The

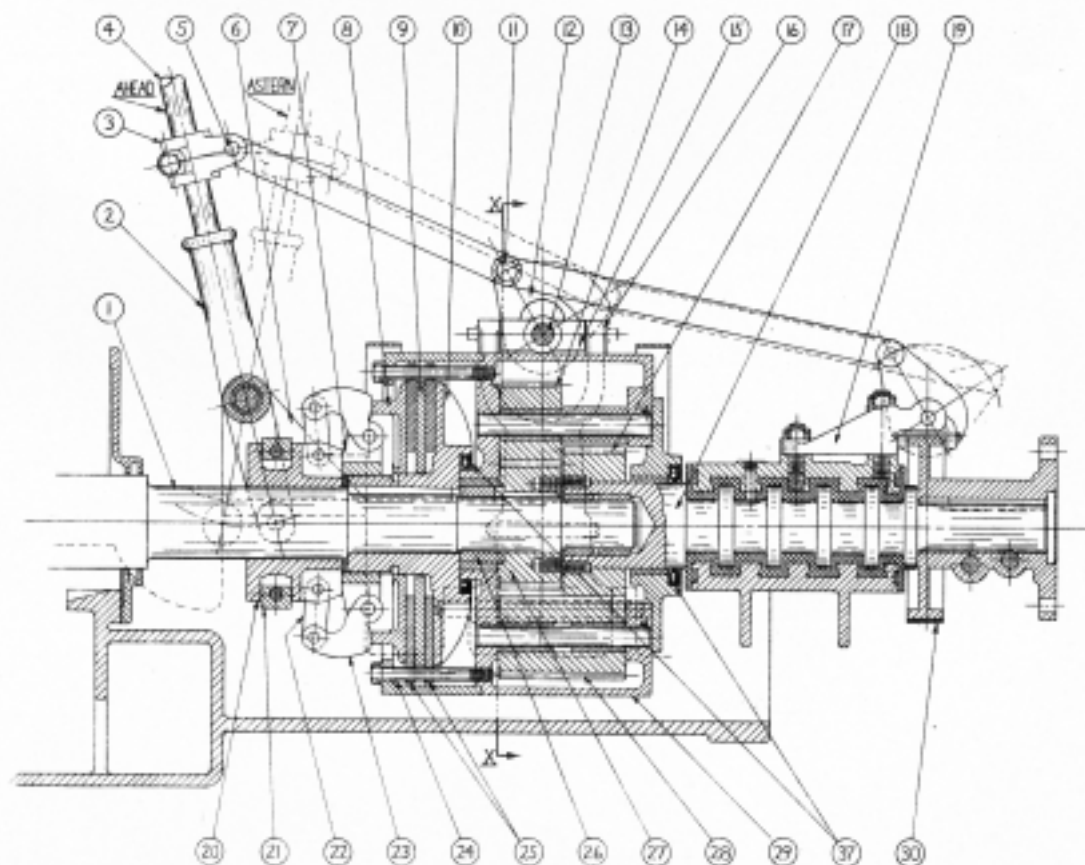

FIG. S-1

Section S

size designation of the gears is the diameter of the transmission drum in inches. Two different types of control mechanism are used, a single operating lever on the 14", 19", and 21" gears, and a rotating shaft, operated by a handwheel and geared to the clutch crowder collar on the 24" and 28" gears.

2. PLANETARY TRANSMISSION

Referring to Fig. S-1, the planetary transmission is housed in a rotating drum (29). It consists of two shaft gears (17) and (27), mounted side by side on adjacent ends of crankshaft (1) and thrust shaft (18), and interconnected by three pairs of "planet" gears, (14) and (28). These planet gears rotate on bronze bushings on pins mounted in drum (29). The long planet gears (28) extend across the faces of both of the shaft gears, meshing with the larger thrust shaft gear (17) and clearing the smaller crankshaft gear (27). The short planet gears (14) are in line with the crankshaft gear and the extension of the long planet gears, meshing with both of these gears and completing the gear train between the two shafts. Fig. S-2 shows a section taken through the planetary transmission at XX in Fig. S-1 and illustrates the planet gear mounting. The above general description applies to all of the different size gears, but there are a number of minor differences in design, the most important of which are as follows:

(a) Drum Mounting

In all of the gears the after end of the drum rotates on the forward end of the thrust shaft. A bronze bushing is pressed into the one piece drum cover on the 15", 19" and 21" gears, but on the 24" and 28" gears a babbit bearing is used, poured in the cover, which is split into two halves. On the 19" and 21" gears, the forward end of the drum rotates on the after end of the clutch drive hub. This hub is larger in diameter than the crankshaft gear so that the drum may be removed without disturbing

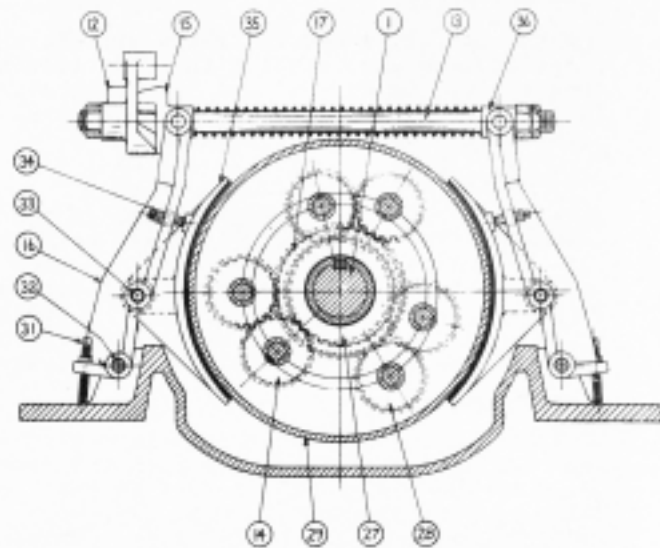

FIG. S-2

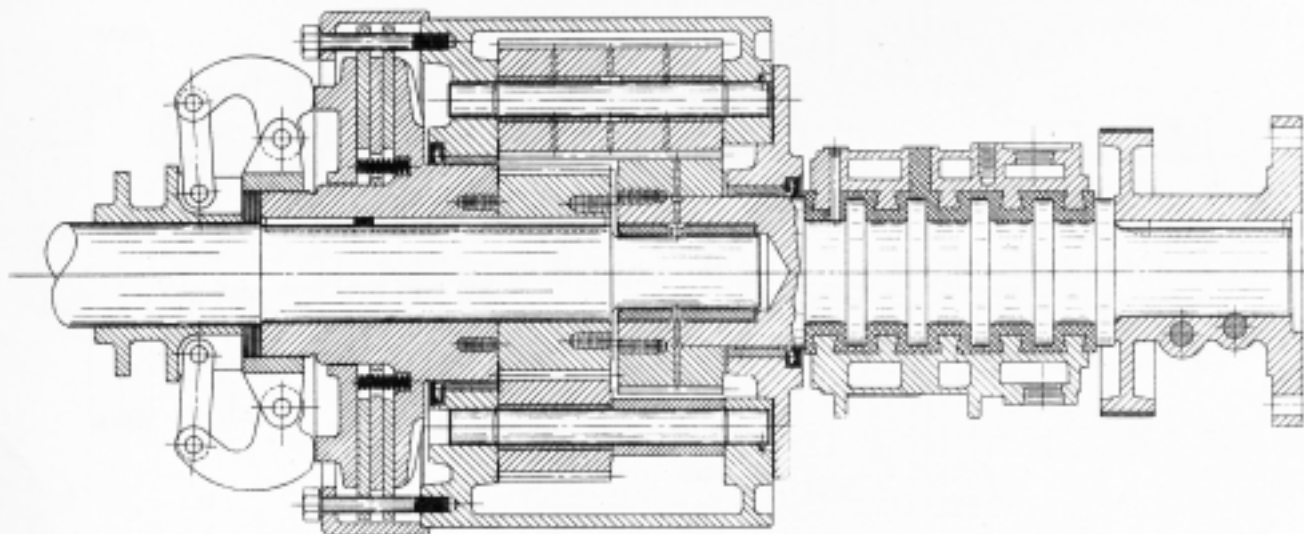

FIG. S-3

the gear. On the 14", 24" and 28" gears however, the bearing in the forward end of the drum is smaller than the crankshaft gear so that the latter must be pulled off the shaft before the drum can be removed. On the 14" gear the forward end of the drum rotates on a spacer on the crankshaft between the clutch driving hub and the crankshaft gear. On the 24" and 28" gears it rotates directly on the crankshaft. In all gears a bronze bushing pressed into the forward end of the drum provides the

bearing. The construction differences may be clearly seen by a comparison of Fig. S-1, Fig. S-3 and Fig. S-4.

(b) Oil Seals

On the 14", 19", and 21" gears oil seals (37) are incorporated into the drum bearings at each end, sealing the drum to the shaft and preventing leakage of oil along the shaft. On the 24" and 28" gears oil seals are not used however, and a heavier grade of lubricant must be used in these drums. Service instructions in regard to lubrication are given in paragraph 9 (a) under MAINTENANCE.

(c) Shaft Keys

The crankshaft drive gear and the clutch driving hub are pressed and keyed to the crankshaft or stub shaft (the 28" gear is mounted on a stub shaft bolted to the end of the crankshaft.) Taper keys are used on the 14" and 28" gears, and straight keys on the 19", 21", and 24" gears. Detailed instructions in regard to fitting the taper keys are given in Paragraph 8 under REASSEMBLY. The straight keys on the 19" and 21" gears are broken under the clutch hub and a felt packing inserted between the ends of the two keys to prevent oil leakage along the shaft.

(d) Thrust Ring

The 24" and 28" gears are provided with thrust rings, shown in Fig. S-4. Four springs acting on this ring push the drum forward when the clutch is disengaged, holding the clutch plates free so that they do not drag. In the 19" and 21" gears similar springs shown in Fig. S-3, work between the plates to hold them apart. No springs are used in the 14" gear. These springs should be replaced when overhauling if they are broken.

3. CLUTCH

The plate clutch acts between the crankshaft and the planetary transmission drum. Referring to Fig. S-1 the clutch driving hub (10) is keyed and pressed on the after end of the crankshaft, just forward of the crankshaft drive gear. Crowder collar (7) is screwed and clamped to the end of the clutch driving hub and a square hub on the latter engages the driving plates (8) and (9). The driven plates (25) are connected to transmission drum (29) by capscrews (24) which engage holes in the plates and also retain the clutch cover to the drum. Four floating clutch plates - two drive and two driven - are used on the 14", 19", and 21" gears, and five are used on the 24" and 28" gears. (On earlier engines only three floating plates were used on the large gears.)

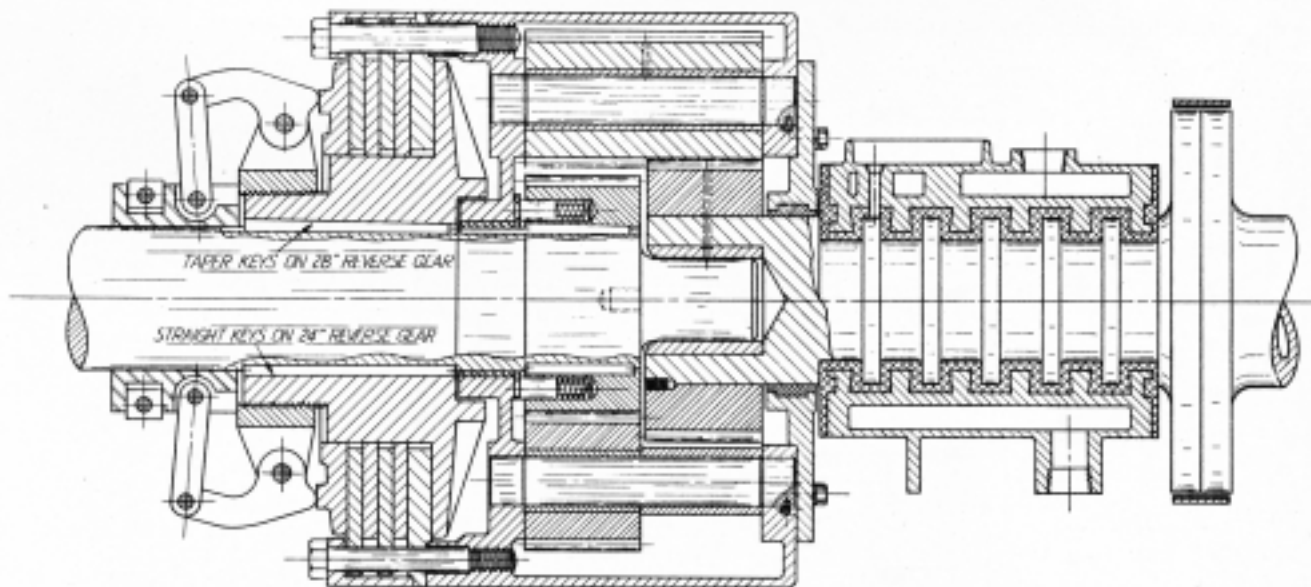

FIG. S-4

The clutch is engaged or disengaged by means of shifter cone (20) (See Fig. S-1) which slides fore and aft on the crankshaft and to which links operating the crowd-ers (23) are pinned. When the clutch is engaged the cone is aft, bearing against crowder collar (7). In this position the center line of links (22) are inclined slightly forward. In other words the pins connecting the links to the cone have been moved in past center, so that the crowding force tends to hold the cone aft,

Section S

with the clutch engaged, rather than to push it forward, disengaging the clutch. The cone is moved by means of fingers extending down from cone shifter (2) and engaging pins projecting from each side of cone collar (21). The cone shifter is mounted on a shaft supported by brackets (6) on each side of engine base. On the 14", 19", and 21" gears the cone shifter is turned directly by clutch operating lever (4) which is inserted into a socket cast in the shifter. On the 24" gear which is equipped with the handwheel clutch control a pinion on the handwheel shaft engages an internal gear sector which is bolted to a flange on one end of the cone shifter casting. Both the shifter and handwheel shaft are mounted on bracket stands bolted to either side of the engine base. On the 28" gears a jack shaft is used between the shifter and handwheel shaft. A pinion on the handwheel shaft engages a gear on the jack shaft, and two pinions on the latter engage the shifter sectors. The two sectors rotate on a third shaft, and levers cast integrally with them extend down to engage the pins in the cone shifter collar.

Instructions covering the care and adjustment of the clutch are given in Paragraph 9 (b) under MAINTENANCE.

4. PLANETARY TRANSMISSION DRUM BRAKE

The brake controlling the planetary transmission drum consists of two shoes (35) (See Fig. S-2) which float on pins (33) on each side of the drum. The pins are carried by brake posts (16), which are supported at the bottom on fulcrum pins (32) extending through lugs on the engine base. Blocks, (15) & (36) swiveled in the tops of the posts are tied together by means of tie rod (13). Swivel block (15) is cam shaped and bears against a mating cam or crowder (12), which is rotated by means of a link connecting to the clutch operating lever. As the crowder is rotated it climbs up on the cam, shortening the tie rod and pressing the brake shoes in against the drum, applying the brake. The foregoing applies to all of the brakes except that on the 24" reverse gear, in which a sliding wedge mechanism is used for the crowder in place of the rotating cam. On the 28" gear two rotating crowder cams are used, one on each side, operated from levers on the handwheel jack shaft.

5. PROPELLER SHAFT BRAKE

A brake band (30) (See Fig. S-1) is used for the propeller shaft brake, wrapped around the drum on the shaft coupling. It is supported by a bracket (19) bolted to the top of the thrust bearing cap, and is operated by a link from the gear drum brake mechanism. A rotating crowder cam is used on most of the designs, but in some cases a sliding wedge is used. In either construction the cam or wedge design is such that the brake is applied and released at the desired points in the operating cycle. Instructions for adjusting and servicing the brakes are given in Paragraph 9 (c).

6. OPERATION OF REVERSE GEAR

When the clutch is engaged the crankshaft is coupled to the drum of the planetary transmission. The transmission is locked and provides a positive connection between the crankshaft and thrust shaft, the propeller shaft rotating with the engine. Both brakes are released. This is the AHEAD position, and the clutch control lever on the 14", 19", and 21" gears is slightly forward of the vertical. As the control lever is moved aft to NEUTRAL the clutch is released, breaking the drive between the crankshaft and thrust shaft. The same motion of the control lever applies the propeller shaft brake, stopping rotation of this shaft. The planetary transmission drum then rotates in the ahead direction somewhat slower than the engine. When the control lever is moved further aft to the ASTERN position, the propeller shaft brake is released and the drum brake is applied. As the drum stops rotating the propeller shaft begins to rotate astern, reaching full speed astern when the drum comes to rest. The operation of the 24" and 28" gears is the same as described above, except that the control is by means of the handwheel instead of by the operating lever.

7. THRUST BEARING

The multi collar thrust bearing is mounted on the after end of the engine base and carries all loads in a fore and aft direction resulting from the propeller thrust. It is made up of three parts, the bearing, the cap and the shaft. Both bearing and cap contain a series of dovetailed circumferential grooves, which when lined with babbitt about 1/4" thick, form grooves for the thrust shaft collars. Between the grooves the cylindrical areas are also babbitt lined and bear against the shaft so that sufficient journal area to carry a substantial radial load is incorporated in the bearing. Five different sizes of thrust bearing are used, corresponding to the five reverse gear sizes. All are very similar in design, with the exception of that in the 14" reverse gear, which is not water jacketed. The four larger sizes are jacketed both in the bearing and cap and a small amount of water is piped from the water pump to the bearing and is then discharged overboard. All of the bearings are lubricated from the engine lubricator. Instructions for the proper care of the thrust bearing are given in Paragraph 9 (d).

8. DISMANTLING AND REASSEMBLING THE REVERSE GEAR

When dismantling the reverse gear, proceed as follows:

- (a) Remove all the clutch and brake control rigging.
- (b) Break the propeller shaft coupling and slide the propeller shaft aft a sufficient distance to remove the thrust bearing. If an intermediate shaft is used it may be removed if desired, rather than shifting the propeller shaft.
- (c) Remove the bolts and dowels holding the thrust bearing to the base.
- (d) Remove the capscrews holding the after cover to the reverse gear drum.
- (e) Remove the thrust bearing with the shaft and drum cover. Note that the bearing must be moved straight back until the pilot on the after end of the crankshaft clears the bore in the thrust shaft.
- (f) Pull the crankshaft gear. Tapped holes in accordance with the following tabulation are provided in the gear and clutch hub and in the end of the crankshaft for use when dismantling and reassembling these parts.

Reverse Gear Size	Hole In Gear	Hole In Clutch Hub	Hole In Crankshaft
14"	5/8"-11 thds/in.	5/8"-11 thds/in.	1"-8 thds/in.
19"	5/8"-11 "	5/8"-11 "	1"-8 "
21"	3/4"-10 "	3/4"-10 "	1-1/4"-7 thds/in.
24"	1"-8 "	7/8"-9 "	1-1/2"-6 "
28"	1"-8 "	1"-8 "	1-1/2"-6 "

- (g) Remove the capscrews holding the clutch cover to the drum and remove the drum. NOTE: On the 19" and 21" gears only, the drum can be removed without resorting to Step (f). (See Fig. S-3.) On the 14", 24" and 28" gears however, the crankshaft gear must be pulled before removing the drum.
- (h) Press or drive the planet gear pins out of the drum. These pins are a press fit in the forward end of the drum and a sliding fit in the after end.
- (i) Pull the clutch driving hub off the crankshaft.
- (j) Loosen the crowder collar clamp bolts and unscrew the collar from the clutch hub. The clutch plates may then be removed from the hub.

Reassemble in the reverse order, noting particularly the following instructions in regard to fitting the keys:

On the 14" and 28" gear where the clutch hubs and crankshaft gears are held by taper keys (and also on some of the older designs where taper keys were formerly used), new keys must be fitted if the parts are replaced. The keys must be fitted individually, pressing each piece on the shaft in turn, fitting its key, removing it, and then proceeding with the next piece. On the 14" gear, clutch hub (10) (See Fig. S-1) must be pressed on the shaft without shifter cone (20) being in place. The taper key is driven in and marked at the end of the hub. The hub is then pulled and the key cut off where marked. The crankshaft gear is then pressed on to its final location, allowing exactly the correct space behind it for the clutch hub and spacer (26). The key is fitted and driven in and the end marked, leaving sufficient projection to engage the notch in the end of the spacer. The parts may then be finally assembled on the shaft, pressing the clutch hub and gear home on their respective keys. The end of the key for the clutch hub must be securely blocked to prevent its backing away as the hub is pressed against it. Substantially the same procedure is followed on the 28" gear, the difference being that spacer (26) is not used. (See Fig. S-4.) The key for the gear is allowed to extend along the shaft to the clutch hub, and the extension is filed down to the contour of the shaft. This is necessary to prevent oil leakage along the shaft. The keys must be fitted for each part individually prior to the final assembly, as described above for the 14" gear.

9. ADJUSTMENT AND MAINTENANCE

(a) Planetary Transmission

On engines with 14", 19", and 21" gears, in which oil seals are used, the drum should be kept from one third to one half full of a good grade of 600W cylinder oil. Pipe plugs for filling are provided in the after end of the drum and the level should be inspected frequently and oil added as necessary. The drum should be

Section S

drained and refilled with new oil every six months to a year, depending on the service. On the larger engines, with 24" and 28" gears the drum is not entirely oil tight and a heavier lubricant must be used. A mixture of half 600W and half cup grease is recommended. The bronze bushings in the drum and drum cover and in the planet gears are subject to wear and should be replaced when clearances become excessive. New bushings must be reamed after pressing in. Allow clearance of .001" per inch of journal diameter. The floating bronze bushing between the crankshaft pilot and the thrust shaft should be replaced when the clearance in either part exceeds .003" per inch of diameter. On the 24" and 28" gears it may be necessary to repour the babbitt bearing in the after drum cover. If this is done great care must be taken to keep the bore concentric with the finished outside diameter. The oil seals in the smaller gears should be replaced when worn. Whenever the clutch hub is pulled on the 19" and 21" gears the felt packing between the two keys should be replaced when reassembling.

(b) Clutch

On all of the different size gears the clutch adjustment is determined by the location of the crowder collar on the clutch hub. As the clutch plates wear, the collar must be screwed farther onto the hub to keep the clutch tight. It should be sufficiently tight to prevent slipping but should not be unduly tightened, causing excessive strain on the parts. Keep the clamp bolts tight to maintain the adjustment, but use care not to bend or break the clamp ears on the crowder collar.

The clutch plates should be oiled occasionally through holes provided in the clutch cover. If the plates become rough the clutch will tend to grab, and if this condition becomes troublesome it may be corrected by facing off the plates. When the plates have been worn or faced down about 1/16" to 1/8" the crowder collar adjustment will be all taken up and it will be impossible to keep the clutch from slipping. It will then be necessary to replace the clutch plates. Excessive wear in the driving pin holes in the plates may be corrected by drilling new holes or by fitting oversize pins. If new holes are drilled they must be very carefully located to line up with the pins.

The shifter cone collar should be kept well lubricated and should be replaced if excessively worn. Wear in the crowder pins and links will have the same effect as wear of the plates, that is it will reduce the effect of the crowder collar adjustment. It may therefore be possible to postpone replacement of the plates, necessitating a complete overhaul of the clutch, by replacing these minor items. The coil springs tying adjacent pins together take up lost motion and prevent rattling and should be kept in place. The thrust springs between the clutch plates should be replaced if broken.

(c) Brakes

If the drum brake is kept properly adjusted the lining will give long service, but if the adjustment is neglected it may be ruined very quickly. The adjustment is practically the same for all of the different size gears and is described below for the 14" gear. (See Fig. S-2.) Adjusting screws (31) should be set to allow clearance between the drum and the center of the brake shoes equal to approximately 1/32" on the 14" drum and up to 1/16" on the 28" drum. Adjusting nuts (34) should then be set to equalize the clearance at top and bottom of the shoe. If this adjustment is neglected the shoes will drag on the drum and wear the lining unevenly. The adjusting nuts on the tie rod determine the force that is applied to the brake shoe, and should not be set any tighter than is necessary to stop the drum when the gear is in reverse.

The brake shoe lining should be replaced before it wears down to the rivet heads, or the drum will be scored and must be turned down. Use "Raybestos" or other good grade of lining, 1/4" thick.

Referring to Fig. S-1 clamp (3) securing the brake operating link to the clutch control lever is adjustable on the lever, and should be set so that the brakes take up at the proper time in the control cycle. Use care however that this clamp is not raised so high on the lever that the linkage will buckle, that is so that pin (11) will drop down into line with pins (5) and (13) and will then be forced down rather than up when the clutch is thrown out. If this occurs the mechanism will jam and it will be impossible to release the clutch. This condition will be approached gradually as the plates wear, and if not watched for may occur when least expected.

The only adjustment for the propeller shaft brake is the band clearance, and it should be kept just sufficiently tight to stop the shaft when the reverse gear is in NEUTRAL. The instructions above, covering relining the shoes, apply equally well to both brakes.

(d) Thrust Bearing

In all of the reverse gear designs the forward end of the thrust shaft is piloted on the aft end of the crankshaft, with a floating bronze bushing between the two pieces. If the two shafts are out of line this bushing will wear rapidly and the crankshaft will be severely stressed. It is therefore most important that the thrust bearing be kept accurately aligned with the crankshaft. Dowels between the bearing and base provide means of maintaining the original transverse alignment, which was carefully determined in the factory when the engine was erected. The vertical alignment is determined by the shim thickness under the bearing however, and it is essential that the original thickness be maintained when reassembling. Note carefully the shim thickness under each side when dismantling and replace with exactly the same shims. If the thrust bearing is ever replaced or rebabbitted it must be very carefully aligned with the crankshaft and new dowel holes drilled.

In all of the bearing designs the thrust shaft gear is shrunk on the forward end of the shaft. If replaced the new gear should be heated to 600° F. and slipped over the end of the shaft, keeping the end of the gear flush with the end of the shaft. Drill and tap dowel holes down the joint, that is half in each piece and screw in studs for dowels. Cut off flush and prick punch to lock. Use the same number and size of dowels as in the old pieces, and drill oil holes through the gear and shaft corresponding to those in the old parts.

LUBRICATING OIL SYSTEM

1. The lubricating oil system on engines with 6½" bore consists of the day tank (not mounted on the engine), the lubricating oil pressure and sump pumps, the manifold in the base, with leads connecting to the main bearings, and the necessary piping to carry the oil through the system. Engines having 7½", 8", and 9" bore are also equipped with lubricating oil filters and coolers. In addition to the main lubricating oil system as outlined above there is also the Madison-Kipp lubricator, supplying a measured quantity of oil to each piston and cylinder liner. The normal oil flow is from the day tank to the pressure pump, then through the oil cooler (if used) to the manifold in the base supplying the main bearings. Drilled holes in the crankshaft carry oil to the crankpin bearings and the rifle drilled connecting rods feed the piston pins. The oil from the bearings drains down to a sump in the after end of the base, from which it is sucked up by the scavenge pump and discharged back to the day tank.

On engines equipped with lubricating oil coolers, a four way cock interconnecting the piping to and from the cooler permits bypassing the oil flow around the cooler. The cock should always be thrown quickly from one position to the other and should never be left in an intermediate position.

A relief valve, connected in the line leading to the base manifold, provides means for regulating the pressure on the system. The discharge should be piped by the customer to the lubricating oil day tank, and the valve should be adjusted for 35 to 40 lbs. per square inch, as indicated on the pressure gauge, with the oil hot. Note that low lubricating oil pressure may not necessarily be due to relief valve adjustment, but may result from one or more of the following causes, and their possibilities should be investigated before attempting to correct by readjusting the valve.

- (a) Low lubricating oil level in day tank.
- (b) Restriction in suction pipe to either of the lubricating oil pumps.
- (c) Broken pressure pipe or fitting.
- (d) Crankshaft bearing failure.
- (e) Excessive pump leakage.
- (f) Viscosity of oil too low, excessive temperature of oil, or thinning out with fuel oil.

2. LUBRICATING OIL DAY TANK

The cylindrical lubricating oil day tank, has a capacity of about 12 gallons on engines with 6½" bore and about 17 gallons on engines with 7½" or larger bore. It should be mounted vertically, with the bottom at least three feet above the engine room floor, and should be piped by the customer to the discharge from the lubricating oil sump pump and the suction of the pressure pump. The connections should be of 1" pipe, the former leading to the pipe tap hole in the casting soldered to the top of the tank and the latter to the hole 6" above the bottom of the tank. A drain valve should be connected to the bottom connection.

A gage glass near the top indicates the oil level, which should be maintained between the center and top of the glass when the engine is running. Under no circumstances should it be permitted to drop below the glass. The tank should be drained and flushed out at intervals to keep the sludge in the bottom from building up to the pump suction connection. New oil should be added to the system through the filler hole in the top of the tank, which is protected by a screen.

3. LUBRICATING OIL PUMPS.

The rotary pump group, illustrated in Fig. T-1, is built into one of the center frame doors (3). It includes the lubricating oil pressure and sump pumps (14) and (17) and the fuel transfer pump (1), together with drive shaft (10) and gear (9), which meshes with a driving gear on the cam shaft. The door is positioned and doweled on the centerframe for .004" gear backlash. The door gasket should be 1/32" thick to maintain this adjustment.

The gear is pressed on the drive shaft, which rotates on ball bearings (11) and (8). The bearings are retained in the housing by pressure pump body (13) and cover (5). The end clearance of the shaft is determined by the thickness of gaskets (12) and (6) under these two pieces, and should be maintained between .005" and .010". The gasket thickness should be 1/32". Never assemble without these gaskets, or the assembly will bind and the bearings will soon fail. The large bearing is mounted directly on the drive shaft, and the small one is mounted on sleeve (4), which is pressed over the fuel transfer pump end of the shaft and serves to align the two shafts. Flats on the mating ends of the shafts form the drive, and an oil seal pressed into cover (5) prevents oil leakage along the sleeve. When replacing the

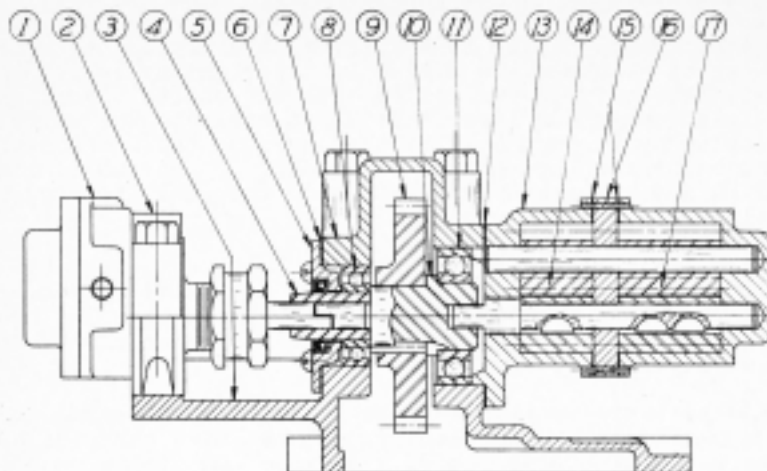

FIG. T-1

saddles bored in the centerframe door and are retained in place by caps (2) and (7) bolted to the door. The lubricating oil pressure pump is centered in the saddle bore by a spigot turned on the end of pump housing (13), so that alignment between the two pumps and the drive shaft is assured.

4. LUBRICATING OIL FILTER (Engines with $7\frac{1}{2}$ " or larger bore)

The lubricating oil filter is connected in a bypass line from the lubricating oil pump discharge. The filtered oil supplies the bearings on each end of the camshaft, the intermediate gear bearing, the governor and the water pump drive.

The filter is of the metal element type as shown on Fig. T-2. The elements are made up of flat metal ribbon wound around a central spool, adjacent layers being slightly separated from each other by raised ridges running across the ribbon. The successive layers of the ribbon are spaced .003" apart and it is these spaces that form the filtering medium. The oil flows from the outside toward the center and leaves the dirt on the outside of the spool. The filter may be cleaned by turning the cleaning handles on top, which rotates a knife bearing on the edge of the windings, scraping off the dirt and allowing it to settle to the bottom of the sump tank. The filter should preferably be cleaned when the engine is not running so that the dirt may settle to the bottom, although there is no objection to cleaning with the engine running. Cleaning should be at sufficiently frequent intervals to prevent stoppage of oil flow and the sump tanks should be drained before the dirt in the bottom builds up to the level of the elements. Experience will determine the correct in-



FIG. T-2

oil seal, assemble in the cover as shown in Fig. T-1.

Spacer (16) separates the lubricating oil sump and pressure pumps, and .004" thick paper gaskets (15) seal the spacers to the two pump housings and also determine the end clearances for the pump gears, which should be from .002" to .005". Never assemble the pumps without these gaskets or the gears will bind. Alignment between the two pumps is maintained by means of dowel pins between the pump housings and spacer (16).

The drive shaft assembly and the fuel transfer pumps are mounted in

tervals.

5. LUBRICATING OIL COOLER (Engines with $7\frac{1}{2}$ " or larger bore)

The Ross tube type lubricating oil cooler is mounted vertically on the water inlet manifold. The tube sheets at each end are brazed to the seamless copper shell, and the ends of the admiralty bronze tubes are rolled into the sheets. Vertical baffles in the water inlet manifold flange and lower tube sheet separate the water inlet and discharge, the water flowing up through half of the tubes to the bonnet which covers the upper tube sheet and returning through the other half of the tubes. The flow of oil around the tubes is guided by bronze baffles inside the shell to produce the most efficient heat transfer.

The necessity for cleaning the cooler will depend upon the service and the nature of the cooling water and lubricating oil used, and will be indicated by decrease in cooling efficiency and increase in pressure drop through the unit. The cooler should be inspected after the first 500 hours of operation and should be regularly inspected, and cleaned whenever necessary.

There are many good scale solvents available on the market for removing the lime and iron rust scale from the water side of the cooler, but use care that the solution used does not attack the material of the cooler. Be sure that it is recommended by the manufacturer for the type of cooler on which it is to be used. A satisfactory solution may be made up of 10% muriatic acid (one pint of acid per gallon of water) with 1 lb. Grasselli No. 3 inhibitor to 50 gallons of solution. Plug the oil connections to the cooler, remove the top bonnet and immerse in the solution. The cleaning action of the solvent is evidenced by bubbling and foaming. When the bubbling stops inspect the tubes and if all scale has not been removed the process should be repeated with a fresh solution.

As soon as all scale is removed the cooler should be very thoroughly washed by flushing with fresh water and then dried with compressed air.

The oil side of the cooler can best be cleaned with carbon-tetra chloride, although gasoline or kerosene can be used. The carbon-tetra chloride will do the job better and quicker, and is non-inflammable. In any event the cleaning should be done in the open or in a well ventilated room. The cleaning solvent should be forced through the core with a hand pump until all of the sludge and dirt has been washed out. Never use wires or prods, as they can only reach a small area adjacent to the openings and may damage the tubes. Never allow the cooler to stand before cleaning after the oil has been drained, as the carbon deposit and sludge will soon harden and will be much more difficult to remove.

6. LUBRICATOR AND DRIVE

The Madison-Kipp lubricator supplies a measured quantity of lubricating oil to the pistons, introduced at the center of the liner on each side. Nipples screwed into the liners and projecting through the cylinders and sealed thereto by packing glands carry the oil through the water jackets. It also feeds oil to the air compressor cylinder and to the thrust bearing.

The lubricator is fully described in the Madison-Kipp bulletin attached at the end of the book. Oil feeds to the pistons should be adjusted to 20-25 drops per minute when the engine is new, but this may be reduced to approximately 15 to 20 drops per minute after the pistons and rings have been well worn in. **KEEP THE LUBRICATOR WELL FILLED WITH CLEAN OIL.** Use the same oil that is used in the engine. Do not under any circumstances allow it to run dry as serious damage to the pistons and liners may result. This should be made a regular part of the engine room routine and should never be neglected. The lubricator is mounted on a bracket on the forward end of the engine, and is driven from an eccentric on the end of the camshaft.

WS - Ed 2 (3)

1. COOLING WATER SYSTEM (2 Cylinder engines with 6½" bore only)

The single acting plunger type cooling water pump is mounted on the forward end of the centerframe and is driven by a connecting rod from a crank on the end of the camshaft. The crank disc is secured to the shaft by a taper key. The bronze plunger is guided in the cylinder bore and is sealed to the cylinder by a packing gland. Do not tighten the gland more than necessary, allowing slight leakage for lubrication. The spring loaded rubber disc valves are mounted in bonnets on a grid which is bolted to the pump body. The construction of the pump is illustrated on the Parts Catalog Plate facing the water pump group list sheet. The cooling water inlet manifold carries the water from the pump to the cylinder water jackets, and pass-over pipes form the connections between the cylinders and the heads. The water outlet manifold collects the flow from each head and discharges into the forward end of the exhaust manifold water jacket. The overboard discharge is taken from the after end of this manifold.

A parallel flow, through the air compressor water jacket, is taken from the water inlet manifold and discharges into the water outlet pipe from the exhaust manifold.

The cooling system may be drained by loosening one of the cover plates on the water inlet manifold. If the engine is to stand in freezing weather the water pump must also be drained by removing the pipe plug in the suction valve bonnet.

2. COOLING WATER SYSTEM (3 & 4 Cylinder Engines with 6½" and larger bores)

All engines included under this listing are equipped with centrifugal circulating water pumps and plunger type bilge pumps, and engines with 7½" and larger bore also have lubricating oil coolers.

The cooling water enters the engine at the suction flange of the circulating water pump and is piped to the water inlet manifold extending along the cylinders. On engines equipped with lubricating oil coolers, the cooler is mounted on the water inlet manifold, cored passages in this casting conducting the water through the cooler tubes and then distributing it to the separate cylinder water jackets. The water is carried from the cylinder to the head by means of an external pass-over pipe, or by pipe nipples screwed into the top of the cylinders and projecting up into the cylinder head. These nipples are sealed with rubber grommets. Always use new grommets and do not coat with white lead or other sealing compound. The water outlet manifold carries the water from the cylinder heads to the forward end of the exhaust manifold water jacket, and the overboard discharge of the engine is from the after end of this manifold.

In addition to the main flow described above there are two minor parallel circuits as follows:

- (a) The air compressor circuit, leading from the water inlet manifold to the air compressor cylinder, through a pass over pipe to the head and discharging into the exhaust manifold jacket outlet pipe.
- (b) On engines with 7½" or larger bore, the thrust bearing circuit. Water is piped from the inlet manifold to the bottom of the thrust bearing jacket, up into the cap through a pass-over pipe and is discharged overboard. A cock in the inlet pipe just below the bearing provides means of draining the engine cooling system.

Be sure that all water is drained from the jackets before pulling a cylinder liner, or it will spill inside the engine. The circulating water pump and bilge pump are not emptied by this drain, and if the engine is allowed to stand in freezing weather these pumps must be drained. A plug is provided in the bottom of the circulating water pump casing, and the bilge pump can best be drained by loosening the capscrews holding the valve grid to the pump body.

3. CIRCULATING WATER PUMP (3 & 4 Cyl. Engines with 6½" and larger bores)

The centrifugal water pump is mounted on the manifold side of the engine and is chain driven from a sprocket on the crankshaft. All of the parts that come in contact with the water are brass or bronze. The impeller is screwed, riveted and doweled to the shaft, which rotates in a babbitt lined bushing pressed into the pump housing. A grease cup provides for lubrication and should be screwed down daily. The .010" paper gasket under the suction cover allows approximately .020" end clearance for the impeller. A packing gland forms the water seal for the shaft, and should not be tightened unnecessarily. Some leakage should be allowed for lubrication of the flax packing.

The drive end of the shaft is supported by a roller bearing, which is clamped in a bracket bolted to the pump housing. An oil cup provides lubrication. The pump body

Section W

is bolted to the engine base and should be carefully shimmed up into line with the drive shaft and the shafts aligned horizontally before tightening the mounting bolts.

4. CIRCULATING WATER PUMP DRIVE (3 & 4 Cyl. engines with 6½" bore)

The crankshaft sprocket for the water pump drive chain is pressed onto a hub on the compressor eccentric, and is locked in place by two 1/2" threaded dowels screwed into holes drilled and tapped down to the joint, that is half in each piece.

The pump drive shaft is mounted in a bracket bolted to the side of the engine base. The two ball bearings on which the shaft rotates are mounted in split adaptors which are clamped in saddles in the bracket. The adaptors are located in the saddles by dowels, and oil cups in the saddle cap provide for lubrication. The inner races of the bearings are locked in place on the shaft by clamp type adaptors, secured by lock nuts. The chain sprocket is pressed on the shaft between the two bearings. The bearings may be moved fore and aft in the adaptors before the saddle clamps are tightened, and the assembly should be adjusted to line up the sprocket with the crankshaft sprocket. Then the two halves of the coupling between the pump shaft and drive shaft should be bolted together after making sure that both shafts are in proper alignment.

The two keyed hubs of this coupling should be separated by 1/8". Keep coupling well lubricated, using SAE #70 or heavier oil (not grease). An oil hole is provided for this purpose. When full, oil will run out through space between hub and outer flange. If the Atlas clamp type of coupling is used, no lubrication is required, but extreme care must be exercised when assembling that both pump and drive shaft are in perfect alignment. An idler sprocket mounted on the end of the centerframe provides means of tightening the Whitney Silent type drive chain. The idler sprocket mounting bracket is clamped to the centerframe, and the chain adjustment is secured by means of a stud projecting from the bracket up through the top of the centerframe. As the nut on the stud is screwed down the bracket is raised, tightening the chain. A jam nut locks the stud adjustment. Slotted holes for the bracket mounting bolts allow the bracket to move, and of course the bolts must be loosened when making the adjustment. Keep the chain tight enough to prevent whipping, but do not tighten unduly.

The idler sprocket rotates on ball bearings which are clamped together against a spacer by the mounting shaft. The sprocket is held in place by a snap ring between the two bearings. Lubricating oil from the pressure pump is fed to the bearings through the hollow mounting shaft.

5. CIRCULATING WATER PUMP DRIVE (Engines with 7½" & larger bore)

The water pump drive for the larger engines is similar to that described in Paragraph 4, with the following exceptions:

- (a) The drive sprocket on the crankshaft is split into two halves and is bolted to the air compressor eccentric.
- (b) The mounting of the pump drive shaft bearings is slightly different, although the general arrangement is quite similar. The bearings are mounted directly in the drive housing and end cover thereto, without use of the clamping adaptors. The driven sprocket is pressed on the shaft and secured by a taper key. It should be located to line up with the crankshaft sprocket. An oil seal in the housing cover seals the shaft against oil leakage. Oil cups are provided for lubrication.
- (c) The idler sprocket for adjusting the chain tension is mounted on an eccentric shaft, so arranged that the position of the sprocket can be adjusted by rotating the shaft. The sprocket turns on a roller bearing on the eccentric part of the shaft. When dismantling, remove the adjusting flange from the projecting end of the shaft and then the two bearings on which the shaft is mounted. The shaft and sprocket can then be moved to place the eccentric part of the shaft in line with the hole in the housing and the shaft withdrawn from the bearing.

The assembly is locked in place, after securing the correct adjustment, by means of an indexing pin. Do not run chain tighter than necessary to prevent whipping. The idler housing is bolted to the top of the pump drive bracket on the side of the base, the entire pump drive assembly being contained within the one unit. An oil line from the pressure pump to the end of the eccentric shaft provides lubrication. The construction is illustrated in the Parts Catalog Plate facing the centrifugal water pump group drive sheet.

6. BILGE PUMPS (3 & 4 Cylinder engines with 6½" & larger bore)

The single acting plunger type bilge pump is mounted on the forward end of the cen-

terframe and is driven by means of a connecting rod from a crank pressed on the end of the camshaft. The crank disc is secured to the shaft by a taper key. The bronze plunger is guided in the cylinder bore and is sealed to the cylinder by a packing gland. Do not tighten the gland unnecessarily, allowing slight leakage to provide lubrication. The spring loaded disc valves are mounted in bonnets on a grid which is bolted to the pump body. The pump construction is illustrated on the Parts Catalog Plate facing the bilge pump group sheet. The bilge pump discharge is connected by means of a three way cock to the water inlet manifold, and in an emergency the engine may be run, AT SLOW SPEED ONLY, on this pump. Means should be provided for connecting the suction to a sea cock if this use is anticipated. The bilge pump is not drained by the main drain cock at the thrust bearing, and if the engine is to be exposed to freezing weather the drain plug in the suction valve bonnet should be removed.

W5 - Ed 2 (3)

AIR COMPRESSOR1. SINGLE STAGE AIR COMPRESSOR

(1) 2 P3 - 2 X

The single stage, single acting air compressor is located on the after end of the engine. A 3" bore compressor is used on 6 $\frac{1}{2}$ " bore engines and a 4" compressor on larger engines. The cast iron, water jacketed cylinder is bolted to the top of the centerframe directly behind the aftermost cylinder. The spring loaded poppet type suction and discharge valves are mounted in the cylinder head, the suction valve in a replaceable guide bushing pressed into the head and the discharge valve in a cage. Both valves seat directly in the head. A grid between the cylinder and head prevents possibility of the suction valve dropping down onto the piston in the event of breakage of the valve stem or of the spring retaining nut coming loose. The manual unloading handle is mounted on the discharge valve cage retaining cap. When the air pressure in the receiver has been built up to the desired value, usually about 225 lbs. per sq. inch, the compressor should be unloaded by turning the handle in line with the inlet valve, which it then holds open. If the compressor is not unloaded the safety valve will pop at 250 lbs. per sq. inch.

The piston, which is driven from the crankshaft by a connecting rod, strap and eccentric, is fitted in the cylinder with a clearance of .002" to .004" on the 3" compressor and .003" to .005" on the 4" unit. Three 1/4" wide piston rings are used, all above the pin. The top two are compression rings and the bottom one is a ventilated oil control ring. Ring side clearance is .002 to .004" and the gap clearance should be .012" for the compression rings and .006" for the oil rings.

The wrist pin has a fit .0005" loose or .0005" tight in the piston bore and a clearance of .0005" to .0015" in the connecting rod bushing. If the bushing is replaced it should be reamed to size or .0005" oversize after pressing in. The pin is secured in the piston by a setscrew threaded into one of the pin bosses and engaging a recess in the pin. It is locked by a jam nut. Shims between the foot of the connecting rod and the strap allow adjustment of the piston height. The top of the piston should be set so that it just comes up to the bottom of the grid, which should be placed in position without any gasket between it and the cylinder. In final assembly when the gasket is in place between the grid and cylinder the gasket thickness will allow the proper clearance between the piston and grid. Be sure that the cylinder nuts are tight when making the adjustment. The strap is allowed a diametral clearance of .005" - .009" and a side clearance of .003" - .006".

MAINTENANCE & INSPECTION1. GENERAL RULES

Observing the following general rules will go a long way toward insuring satisfactory and trouble-free operation. Refer to preceding sections for detail instructions.

KEEP YOUR ENGINE CLEAN

Inspect the engine regularly and keep it wiped clean. If oil is left standing it quickly hardens and must be washed or scraped off. It is much easier to keep the engine clean than to get it clean, and there is always less trouble with a clean engine than with one that is covered with oil and dirt.

LEAVE WELL ENOUGH ALONE

When the engine is running satisfactorily and smoothly, do not continually try to better the operation with minor adjustments.

NEVER ALLOW YOUR ENGINE TO SMOKE

When the exhaust from an engine is smoky it clearly indicates that combustion is not perfect and that residue, in the shape of smoke, is clinging to the oily surfaces of the cylinders, pistons, piston rings, valves, etc. When this happens you are creating trouble for yourself and doing an injustice to the engine. Therefore, the first thing in consideration of the operation of a Diesel engine is: DO NOT ALLOW YOUR ENGINE TO SMOKE.

KEEP A COMPLETE LOG OF ENGINE OPERATION

A complete log should always be kept of the engine operation, and back sheets should be consulted frequently and compared with present conditions. In this way gradual changes can be detected and investigated and insignificant troubles corrected before becoming real ones. Any unusual noises or other irregularities should be logged so that they will be investigated at the regular routine inspections.

INSPECTING REPAIRS

At completion of any adjustment or repair job, always make a thorough inspection to see that all parts have been correctly replaced, that bolts and nuts are tight, and that all cotter pins and locking wires are in place. If work involved rotating parts, bar engine around at least two full revolutions (so that camshaft is turned one revolution) to be sure that all parts are clear. Be sure that no tools or rags are left inside the engine.

2. SMOKY EXHAUST

Smoky exhaust indicates defective combustion which is usually due to one of the following causes:

- (a) Excessive carbon on spray valve tips.
- (b) Leaking spray valve.
- (c) Leaky exhaust, inlet, or air starting valves.
- (d) Buffer springs may be incorrectly adjusted.
- (e) Fuel cam or roller may be worn.
- (f) Leaky or stuck piston rings.
- (g) Uneven cylinder load balance.

If exhaust smoke is not even but occurs in the form of puffs it is likely that the combustion is defective in one or two cylinders only. Where the trouble lies can usually be determined by cutting out spray valves one at a time. When this is done however, the engine should not carry more than about 3/4 load or the remaining cylinders will be overloaded.

3. INSPECTION AND MAINTENANCE ROUTINE

The following routine for regular inspection and maintenance work is suggested as a

Section Z

guide for the operator, but experience with the engine over a period of time may indicate changes that should be made in the schedule.

It will be noted in the following schedules that spray valve cleaning has not been included. It is believed the spray valves should be cleaned only when necessary, rather than at definite intervals. The necessity for cleaning will be indicated by increased or uneven exhaust temperatures or smoky exhaust and at either of these indications the spray valves should be inspected and cleaned, if necessary.

In the following, work to be done under each routine should include work listed under preceding routines. For example, work under "Annual Routine" includes everything listed under all other routines.

4-HOUR ROUTINE

(a) Hand oil the following points:

1. The inlet and exhaust valve stems.
2. The rocker arms at their fulcrums and at their push rod ends.
3. Inlet and exhaust lifters, fuel wedges, lifter and buffers.
4. Wedge shaft bearings.
5. Tachometer drive (if engine is equipped with tachometer)
6. Circulating or Bilge pump connecting rod - both ends.
7. Mechanical lubricator strap.

For oiling the inlet and exhaust valve stems it is preferable to use penetrating oil. If this is not available a mixture of equal parts of engine lubricating oil and kerosene may be used. (A mixture of two-thirds engine fuel oil and one-third lubricating oil can be used in an emergency.) For all other points in above schedule use engine lubricating oil.

- (b) Check the oil level in the mechanical lubricator. Fill the lubricator with clean engine oil of the grade used in the engine when necessary.
- (c) Turn the handle of the lubricating oil filter (on engines equipped with lubricating oil filters)
- (d) Turn the handle of the fuel oil filter.

Always turn filter handles immediately after stopping the engine.

DAILY OR 24-HOUR ROUTINE

- (a) Clean out the sump tanks of the lubricating oil and fuel oil filters.
- (b) Check the feeds on the mechanical lubricator.
- (c) Hand oil reverse gear clutch plates if clutch is grabbing.

200 TO 300-HOUR ROUTINE

- (a) Check intake and exhaust valve timing.
- (b) Check spray valve timing. (After starting engine check cylinder load balance.) (See Section O)
- (c) Clean out lubricating oil day tank if lubricating oil is dirty or dark in color.
- (d) Remove crankcase doors and inspect connecting rods. Be sure that all connecting rod bolts are tight and that everything is in order. Inspect lower part of cylinder liner bore.
- (e) Check level of lubricant in the reverse gear drum (See Section 8, Paragraph 9 (a)).

SEMI-ANNUAL ROUTINE

- (a) Pull cylinder heads and pistons, remove rings and clean pistons and grooves thoroughly. Check rings for side and end clearance.
- (b) Examine cylinder liner walls. Watch for shoulders due to ring travel.

- (c) Grind intake and exhaust valves. Check valve springs for length and tension and for defects.
- (d) Recondition spray valves. Inspect stem packing and repack if necessary. Inspect stem for wear and replace if worn. Inspect and clean spray valve tips. Grind stem to tip.
- (e) Inspect main and connecting rod bearings. Check clearances and inspect bearing surfaces. Adjust clearances if necessary.
- (f) Inspect gear train carefully, observing backlash, indications of wear on teeth, and clearance on intermediate gear bearings.
- (g) Inspect camshaft. Watch for worn or loose cams, loose or worn rollers or pins on the lifters. Be sure all keys and lock bolts are in place and tight.
- (h) Inspect water pump. Repack stuffing box if necessary.
- (i) Drain reverse gear drum and refill with lubricant as recommended in Paragraph 9 (a) of Section S.
- (j) Check propeller shaft coupling bolts and thrust bearing and fly-wheel clamp bolts.
- (k) Check all hold-down bolts between engine and foundation. If they are loose check the engine alignment.

ANNUAL ROUTINE

- (a) Check crankshaft and thrust shaft alignment. If shaft needs re-alignment it is recommended that the work be done by an experienced and careful mechanic.
- (b) Examine cylinder jackets and exhaust manifold water jackets. If scale is over 1/16" thick it should be removed by scale removed solution. Then flush with water thoroughly.
- (c) Remove and inspect lubricating oil and fuel oil transfer pumps. Note conditions of bearings, shafts, seals and stuffing box. Replace or repack if necessary.
- (d) Inspect high pressure fuel pump. Note condition of pump plungers and barrels. Disassemble crossheads and connecting rods and inspect for wear. Inspect suction and discharge valves and grind seats.
- (e) Disassemble governor and inspect carefully all moving parts for wear and signs of distress. Inspect entire linkage between governor and wedge shaft for lost motion and wear. Fuel wedges, links and pins should also be inspected for wear and replaced if necessary.
- (f) Inspect Mechanical Lubricator and connections to cylinder liners. Inspect ratchet mechanism for wear and proper functioning. Hand crank lubricator and observe the feed to each liner. Watch for water leaks at the nipples going through the water jackets.
- (g) Clean out crankcase thoroughly. Be sure that all cleaning solution is drained out after cleaning is completed.

FOREWORD

This Parts Catalog has been compiled to serve the dual purpose of providing a means for ordering parts and to furnish illustrations to aid in the dismantling and reassembling of the various units of the engine.

This Parts Catalog is made to conform to the original construction of the engine, and the Atlas Imperial Diesel Engine Co. does not assume the responsibility or obligate itself to maintain this catalog to conform to any subsequent changes made on the engine after it leaves the factory. Complete records of all changes and service orders for each engine are maintained at the factory in an effort to always supply correct parts, but due to occasional substitution of parts in the field, of which we have no knowledge, and the fact that we have no assurance that parts furnished from the factory are installed, we cannot guarantee the furnishing of correct parts.

The right is reserved to change the construction or material of any part or parts without incurring the obligation of installing such changes on engines already delivered.

INSTRUCTIONS FOR ORDERING PARTS

Always furnish Engine Number when ordering parts or when communicating with factory or agency. This number will be found on name plate located on operating side of engine. It is VERY NECESSARY THAT THE ENGINE NUMBER BE GIVEN as it helps to insure the furnishing of correct parts and is also the means whereby the factory service records of each engine are maintained.

Always give PART NUMBER, PART NAME AND QUANTITY. If part has no Part Number then give a COMPLETE DESCRIPTION AND SIZE OF PART.

Be particular to state POST OFFICE ADDRESS, TOWN, COUNTY and STATE to which parts are to be shipped.

Specify how merchandise is to be shipped--whether by FREIGHT, EXPRESS or PARCEL POST.

Confirm all Telephone and Telegraph orders in writing.

Claims for shortages or errors must be made within five days from the receipt of goods or same will not be considered.

Broken or damaged goods should be refused, or a complete description made of damage by the carrier agent on the freight bill. If this is done, full damage can generally be collected from the transportation company.

No responsibility is assumed for delay or damage to merchandise while in transit. Our responsibility ceases upon delivery of shipment to the transportation company, from whom a receipt is received showing that shipment was in good condition when delivered to them; therefore, claims if any, should be made with the transportation company and not with the Atlas Imperial Diesel Engine Co.

Code Address: "ATGAS" - OAKLAND --- Codes: BENTLEY'S - PRIVATE

INSTRUCTIONS ON "HOW TO USE PARTS CATALOG"

In order TO LOCATE PART NUMBERS it is IMPERATIVE that the person concerned thoroughly understands the makeup of this book. He should CAREFULLY READ THE INSTRUCTIONS given on this and the following page; and thoroughly familiarize himself with the necessary steps involved. Particularly is this important when sub-assemblies are involved.

DO NOT ORDER PARTS BY REFERENCE NUMBERS as these numbers sometimes change and wrong parts might be supplied.

This catalog is made up of four basic sections, as follows:-

1. INDEX SHEET -- This sheet lists the various groups into which the engine is divided and must be used for obtaining the group sheet number.
2. GROUP LIST SHEET -- This sheet lists the parts which comprise the group, and are numbered with the prefix "L" or "2L".
3. PLATE (OR LINE DRAWING) -- Plates are arranged to face the group sheet to which they apply, and in most cases shows only the parts listed in the group. Occasionally a plate may include two or more groups making it necessary to always first obtain the group number from the index. If this is not done you may by chance turn to a plate showing the part wanted but will not find it listed on the group sheet facing this plate.

NOTE:----- If no plate is found facing the group sheet, then the part wanted can be identified by the description. This will apply mainly to piping, and in this connection the actual pipe and fittings on the engine should always be measured and then ordered accordingly, due to unavoidable variations between engines.

4. SUB-ASSEMBLIES -- The term "Sub-assembly" (or the word "Assembly" appearing in the part name) is used to indicate parts which are made up of two or more parts (or pieces) and yet must be considered as a unit part. For example, parts that are welded together, parts that have bushings pressed in, or parts that have to be machined together.

A Sub-assembly list will be found immediately following the last group sheet, and itemizes the various parts used in each assembly. These assemblies are arranged in numerical sequence and always have the prefix "X", "G" or "GA" in the assembly number.

NOTE:----- Certain parts of assemblies indicated by an "*" in place of a reference number, are not sold individually, and if wanted, the complete assembly must be ordered.

REFERENCE NUMBERS ON PLATES OR ASSEMBLY DRAWINGS

SINGLE NUMBERS or the TOP NUMBER (when more than one number appears in the circle) refers directly to a corresponding number on the group list sheet.

A circle with MORE THAN ONE NUMBER indicates part in question is a component part of a sub-assembly. The top number will refer to a corresponding number on the group list sheet, and the lower number will refer to a corresponding number in the sub-assembly.

TO FIND A PART WITH TWO REFERENCE NUMBERS IN THE CIRCLE PROCEED AS FOLLOWS:- (NOTE:- Select a part on any plate and follow step by step as explained.)

1st -- Using the top number in the circle locate corresponding reference number on the group list sheet, which will be an assembly ("X" or "G" number).

2nd -- Using the Part Number ("X" or "G" No.) of the assembly locate same in the numerical assembly list at rear of book.

3rd -- Refer back to the plate and obtain the second or lower number in the reference circle, then locate this number in the reference number column of the sub-assembly, and this will be the part desired.

If there are MORE THAN TWO NUMBERS in the reference number circle, proceed exactly as outlined above, only this time the part in the first assembly located will be another sub-assembly, so therefore it will be necessary to find the second assembly, and then referring back to the plate take the third number in the reference circle and match it with the corresponding number in the second assembly.

The following page will show a typical example and illustrate the above explanation step by step.

The following illustrated example will show the procedure as explained on opposite Page, for finding parts involved in sub-assemblies.

For this illustration assume that the part number for the Cylinder Head Cleanout Cover is wanted:-

We know that this cover would be listed with the "Cylinder Head" so we turn to the Index Sheet and locate the "Cylinder & Head Group" which gives us the sheet number.

PARTS CATALOG ---- INDEX ENGINE NO. 11830
6 Cyl. 13 x 16 Marine Engine

	No.	Group
BASE SECTION		
Base -- (Studs - Covers - Bearing Caps Etc.).....	1	2L27
Base Oil Piping-(Main Manifold - Crank Brg.Oil Lines).....	1	2L829
Crankshaft & Flywheel -- (Thrust Shaft & Bearing).....	1	2L30
CYLINDER & VALVE MECHANISM SECTION		
Cylinder & Head.....	6	L-9776
Valve Rockers & Push-Rods.....	6	L-9777
Valve Lifters & Guide.....	6	L-8919
Piston & Connecting Rod.....	6	2L351

We find the sheet number for this group to be L-9776, and now we turn to this sheet and opposite we find a Plate or group drawing.

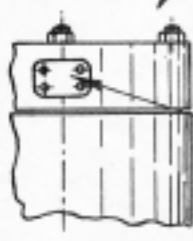

ALWAYS GIVE PART NUMBER-PART NAME-ENGINE NUMBER FOR STD. HARDWARE WITHOUT PART NUMBER GIVE DESCRIPTION AND SIZE * INDICATES PART NOT SERVICED INDIVIDUALLY				PLATE NO.
				L-9776
REP. NO.	PART NO.	NO. REQ'D.	PART NAME	ASSEM. DRWS. NO.
1	X1283	1	CYLINDER ASSEMBLY	
2	753A-FB4	4	WASHER - Cyl. to Centerframe Stud	
3		4	NUT -- 1 3/4-5-NC-Hex. - - (Steel)	
4	X2810	1	HEAD ASSEMBLY - Cylinder	
5	C-3957	1	GASKET - Head to Cylinder	
6	610A-03	8	GROMMET - Cyl. to Head Water By-Pass Pipe	
7		8	NUT -- 1 1/2-6-NC-Hex. - - (Steel)	
8	785	1	FLANGE - Cyl. Head Water Outlet Hole (Blind)	
NAME CYLINDER & HEAD GROUP				L-9776
ORIGINALLY ISSUED FOR 13 x 16 MAR. - STAT.				
FOR TOTAL REQUIREMENT PER ENGINE MULTIPLY NO. REQ'D GIVEN ABOVE BY NO. REQ'D FOR THIS GROUP GIVEN ON INDEX SHEET				
PARTS LIST		ATLAS IMPERIAL DIESEL ENGINE CO.		
		OAKLAND, CALIF.		
		MATTOMO, ILL.		

Looking at the Plate we locate the part we want and find the reference number to be 4-1-8. We now take the top number "4" and match this with the reference number "4" on the group list sheet. We find this to be X2810 Head Assembly, so that this assembly must next be found in the sub-assembly list at rear of book.

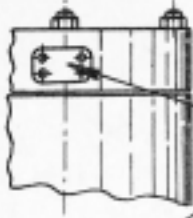

REF. PART NO.	NO. REQ'D.	NAME
X2810		HEAD ASSEM. - CYLINDER -- Includes
1	1	HEAD ASSEM.
2	1	VALVE & CAGE ASSEM.
3	1	VALVE & CAGE ASSEM.
4	2	RING - Piston

After finding assembly X2810 in sub-assembly list, we now take the second of the reference numbers in the oval which is "1" and match this with the corresponding number of the sub-assembly. We find this to be X2818 Head Assembly so we now have to proceed to this assembly.

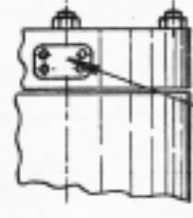

REF. PART NO.	NO. REQ'D.	NAME
X2818		HEAD ASSEM. - CYLINDER -- Includes
*	1	HEAD CYLINDER
*	6	PIPE PLUG -- 1 1/4 Std.
1	4	STUD - In. & Exh. Cage
2	2	STUD - Air Valve Cage
7	2	NOZZLE - Cooling
8	2	COVER - Cleanout (Blind)

After this assembly X2818 is found we now take the bottom reference number in the oval which is "8" and match this with the corresponding reference number in X2818. We now have the unit part which we want.

PARTS CATALOG

ATLAS IMPERIAL DIESEL ENGINE CO.

INDEX CATALOG APPLIES ONLY
TO ENGINES INDICATED

ENG. NO. 12719

ENG. SIZE 9 x 12

No. CYL 4

TYPE Marine - R.H.

TO

INCL

GROUP NAME	NO. USED	GROUP SHEET NUMBER
Base - (Studs - Covers - Brg. Caps - Lube Man.).....	1	L-9877
Crankshaft & Flywheel - (Bear. Shells - Comp. Eccent.)..	1	L-9879
Clutch - Reverse Gear.....	1	L-9867
Reverse Gear & Thrust Bearing.....	1	L-9880
Control - Reverse Gear.....	1	L-8436
Brakes - Rev. Gear Drum & Prop. Shaft.....	1	L-9883
Centerframe & Covers - (Covers - Breather - Pointers)....	1	L-9887
Gear - Intermediate.....	1	L-9504
Camshaft & Fuel Pump Crank (Bearings).....	1	L-9880
Cams.....	4	L-7001
Valve Lifters & Guides.....	4	L-6827
Cylinder & Head (Valves - Compression Relief Valves).....	4	L-9889
Valve Rockers & Push-Rods.....	1	L-9892
Piston & Connecting Rod.....	4	L-8884
Spray Valve - (Clamps - Filter Etc.).....	4	L-9483
Tip - Spray Valve.... ---- Part No. 5843 ----	4	
Manifold - Inlet & Exhaust -- (Air Suct. Silencer).....	1	L-9895
Manifold - Air Starting.....	1	L-8823
Manifolds - Water Inlet & Outlet (& Cooler).....	1	2L443
Fuel Pumps - (Priming & High Pressure).....	1	2L455
Pumps - Lube Oil & Fuel Transfer.....	1	L-9906
Water Pump - Centrifugal.....	1	2L1381
Drive - Centrifugal Water Pump.....	1	2L1384
Pump - Bilge.....	1	L-9902
Governor (Housing - Covers Etc.).....	1	2L865
Control - Governor Speed.....	1	L-3074
Spring - Governor.....	1	L-8076
Control - Fuel Wedge Shaft Hand.....	1	L-7123
Wedge Shaft - Fuel -- (& Linkage to Governor).....	1	L-6904
Spring - Fuel Wedge Shaft.....	1	L-6205
Cylinder & Head - Air Compressor.....	1	L-8508
Piston, Connect. Rod & Eccentric Strap - Air Compressor	1	L-8889
Fuel System (Rail-Tubes-Accumulator-Regulat. Valve).....	1	L-9909
Tank - Fuel -- (Filter).....	1	L-3011
Bracket - Fuel Tank.....	1	L-4552
Piping - Fuel (Low Pressure).....	1	L-8480
Lubricator (Drive - Piping Etc.).....	1	L-9909
Piping - Lube Oil Pressure.....	1	L-9913
Piping - Lube Oil Pressure.....	1	2L446
Filter - Lube Oil.....	1	L-8468
Piping - Water.....	1	L-9915
Pressure Gages.....	1	L-6881

NOTE: When ordering parts substitute the following for those listed:-

High Press. Fuel Line (To Press. Gage - 34" Lg.) -- X146

Gage Board & Bracket are special - order by description only

DATE TYPED 4-2-47

ISSUE NO. 1

INSTR 24 (M-S)

SPEC. NO. 1489-2

ES NO.

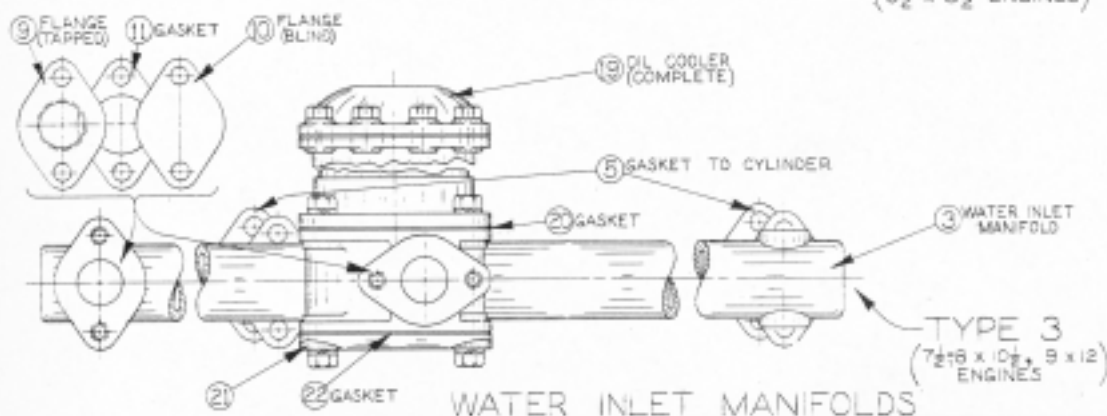
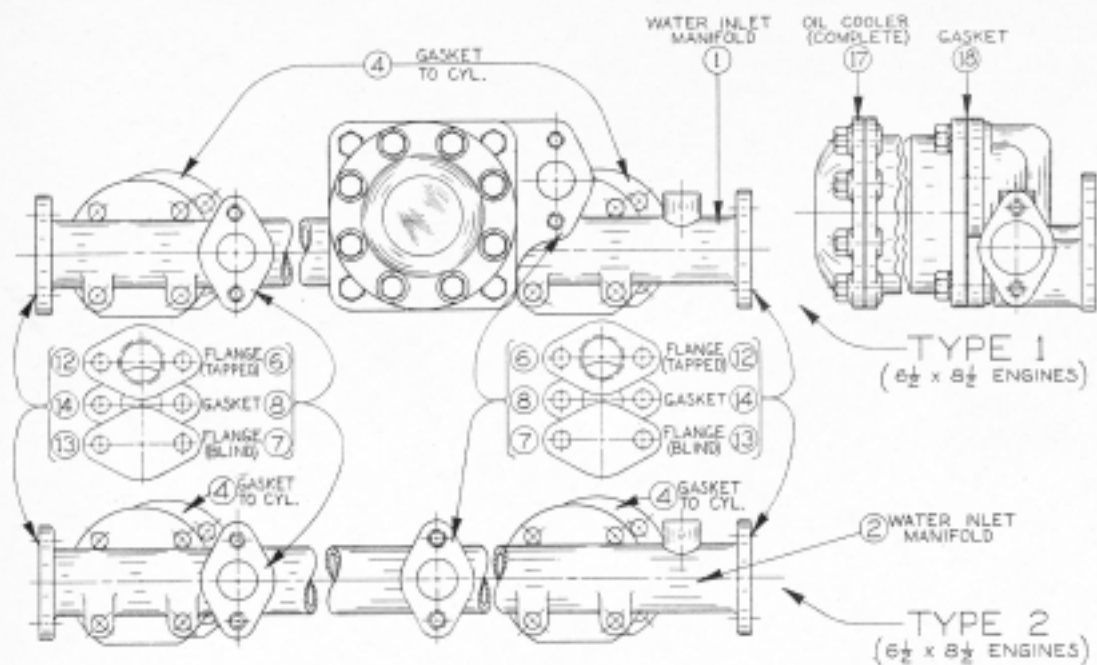

WATER INLET MANIFOLDS

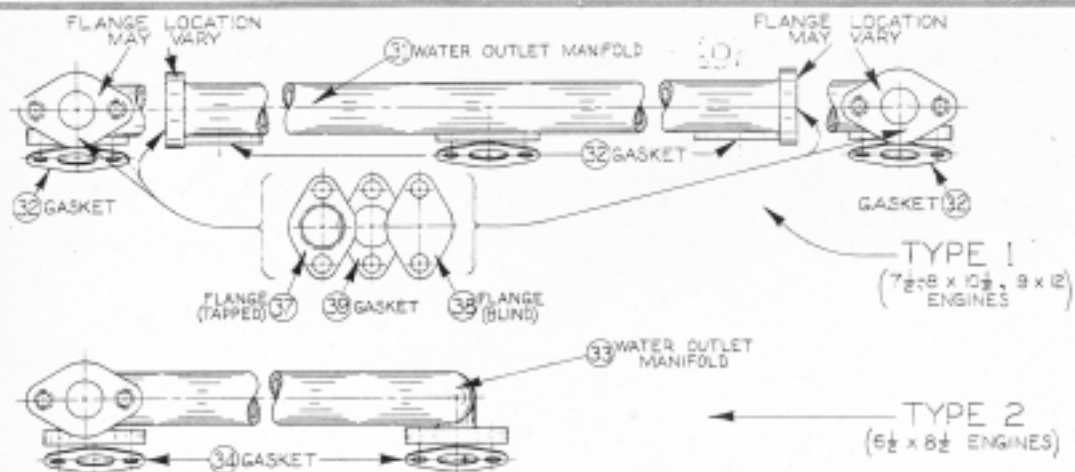

WATER OUTLET MANIFOLDS

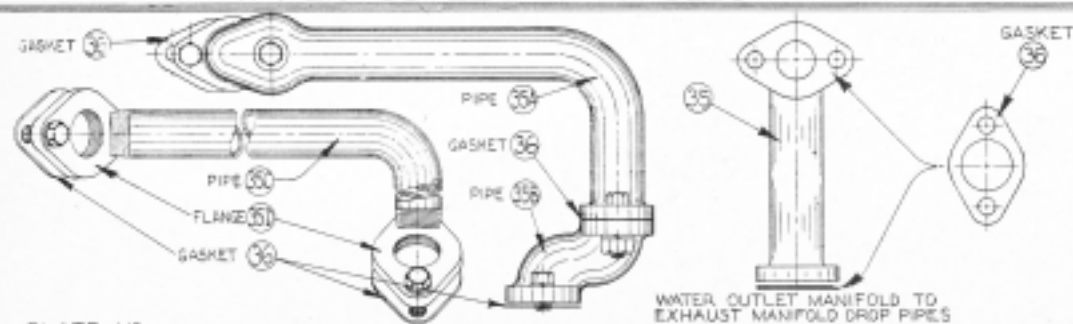

PLATE NO.
K-2154 EP

DO NOT ORDER PARTS BY REF. NUMBERS

#1 Revised & Retyped from 12-17-40

CHANGES

CHANGES

2L443

ALWAYS GIVE PART NUMBER—PART NAME—ENGINE NUMBER
FOR STD. HARDWARE WITHOUT PART NUMBER GIVE DESCRIPTION AND SIZE
* INDICATES PART NOT SERVICED INDIVIDUALLY

PLATE NO. K-2154

LINE NO.	DRWG. NO.	REF. NO.	PART NO.	NO. REQD.	PART NAME	ASSEM. DRWG. NO.
1		3	K-1340	1	MANIFOLD - Water Inlet	
2				1	REDUCING BUSHING (Man. End)--3/4 x 3/8 Std. (C.I.)	
3				1	PIPE PLUG -- 3/4 Std. - - C't's'k Hd.-(C.I.)	
4				1	PIPE PLUG -- 3/8 Std. - - (C.I.)	
5		5	S-1042	4	GASKET - Manifold to Cyl.	
6				8	CAPSCREW -- 1/2-13-NC x 1 1/4 Lg. - (St.)	
7				8	LOCKWASHER -- 1/2 SAE Reg. - - (St.)	
8		9	C-7491	2	FLANGE - Man. Water In. (Cent. & Bilge Pump)	
9		11	S-1042	2	GASKET - Flange to Manifold	
10				4	CAPSCREW -- 1/2-13-NC x 1 1/4 Lg. - (St.)	
11				4	LOCKWASHER -- 1/2 SAE Reg. - - (St.)	
12	2C132	19	2C132-P	1	COOLER - Lube Oil	
13		20	C-5324	1	GASKET - Cooler to Manifold	
14				4	CAPSCREW -- 1/2-13-NC x 1 1/4 Lg.-(St.)	
15				4	LOCKWASHER -- 1/2 SAE Reg. - - (St.)	
16		21	C-8383	1	COVER - Water Inlet Manifold (Bottom)	
17		22	C-8384	1	GASKET - Cover to Manifold	
18				4	CAPSCREW -- 1/2-13-NC x 1 1/4 Lg. - (St.)	
19				4	LOCKWASHER -- 1/2 SAE Reg. - - (St.)	
20						
21		31	F-5512	1	MANIFOLD - Water Outlet	
22		32	S-2334	4	GASKET - Manifold to Cyl. Head	
23				8	CAPSCREW -- 1/2-13-NC x 1 1/4 Lg. - (St.)	
24				8	LOCKWASHER -- 1/2 SAE Reg. - - (St.)	
25	C-8463	35	790-C3	1	PIPE - Water Man. to Ex. Man. Drop	
26		36	S-1042	2	GASKET - Drop Pipe to Manifolds	
27				4	CAPSCREW -- 1/2-13-NC x 1 1/4 Lg. - (St.)	
28				4	LOCKWASHER -- 1/2 SAE Reg. - - (St.)	
29	C-3056	38	786	1	FLANGE - Water Outlet Manifold (Blind)	
30		39	S-1042	1	GASKET - Flange to Manifold	
31				2	CAPSCREW -- 1/2-13-NC x 1 1/4 Lg. - (St.)	
32				2	LOCKWASHER -- 1/2 SAE Reg. - - (St.)	
33						
34						
35						
36						
37						
38						
39						
40						
41						
42						
43						
44						
45						
46						
47						
48						
49						
50						

FOR OFF. HAND REG
2L444

NAME WATER INLET & OUTLET MANIFOLD GROUP

ORIGINALLY ISSUED FOR 4 CYL. 9 x 12 MARINE - R.H.

FOR TOTAL REQUIREMENTS PER ENGINE MULTIPLY NO. REQ'D GIVEN ABOVE BY NO. REQ'D FOR GROUP GIVEN ON INDEX SHEET

PARTS LIST

ATLAS IMPERIAL DIESEL ENGINE CO.
OAKLAND, CALIF. MATTOON, ILL.

2L443

CHANGES

CHANGES

2L446

ALWAYS GIVE PART NUMBER-PART NAME-ENGINE NUMBER
 FOR STD. HARDWARE WITHOUT PART NUMBER GIVE DESCRIPTION AND SIZE
 * INDICATES PART NOT SERVICED INDIVIDUALLY

PLATE NO.

LINE NO.	DRWG. NO.	REF. NO. *	PART NO.	NO. REQ'D.	PART NAME	ASSEM. DRWG. NO. A-218 -- A-219
1					-- Base to Four Way Cock (Inlet & Outlet) --	
2	2C160		2C160-P 1/2	2	UNION ELBOW	
3				1	PIPE(Base Outlet)--1/2 x 22 Lg.(Thr'd. Both Ends	
4					(Brass)	
5				1	PIPE(Base Inlet)--1/2 x 22 Lg.(Thr'd. Both Ends)	
6					(Brass)	
7	2C167		2C167-P 1/2	2	UNION TEE	
8				2	CLOSE NIPPLE -- 1/2 Std. - (Brass)	
9				1	PIPE PLUG -- 1/2 Std. - (Brass)	
10	C-9055		C-9055-P 3/4	1	COCK - Four Way	
11				4	REDUCING BUSHING -- 3/4 x 1/2 Std. - (Brass)	
12						
13						
14					--- Four Way Cock to Cooler (Inlet) ---	
15				1	CLOSE NIPPLE -- 1/2 Std. - (Brass)	
16	2C160		2C160-P 1/2	1	UNION ELBOW	
17				1	PIPE--1/2 x 15 Lg.(Thr'd. 2 Ends)-(Brass)	
18	2C157		2C157-P 1/2	1	UNION	
19				1	CLOSE NIPPLE -- 1/2 Std. - (Brass)	
20						
21						
22					-- Cooler to Four Way Cock (Outlet) --	
23				1	CLOSE NIPPLE -- 1/2 Std. - (Brass)	
24				1	TEE -- 1/2 Std. - (M.I.)	
25				1	PIPE PLUG -- 1/2 Std. - (C.I.)	
26				1	NIPPLE -- 1/2 x 9 Lg. - (Brass)	
27	2C160		2C160-P 1/2	1	UNION ELBOW	
28				1	NIPPLE -- 1/2 x 5 Lg. - (Brass)	
29				1	ELBOW -- 1/2 Std. 45° - (M.I.)	
30				1	CLOSE NIPPLE -- 1/2 Std. - (Brass)	
31				1	STREET ELL -- 1/2 Std. - (M.I.)	
32						
33						
34					-- Base Inlet Pipe to Pressure Gage --	
35	C-9801		C-9801-P 1/4	1	CONNECTOR - Tube Fitting	
36				1	TUBE -- 1/4 O.D. x .030 x 48 Lg. -(S.D. Cop.)	
37	C-9801		C-9801-P 1/4	1	CONNECTOR - Tube Fitting	
38				1	REDUCER (Bell)--1/4 x 1/8 Std. - (M.I.)	
39						
40						
41						
42						
43						
44						
45						
46						
47						
48						
49						
50						

2L446

FOR OFF. HAND SEE

NAME LUBE OIL PIPING GROUP

FOR OFF. HOT. SEE

ORIGINALLY ISSUED FOR 3-4 CYL. 9 x 12

FOR TOTAL REQUIREMENTS PER ENGINE MULTIPLY NO. REQ'D GIVEN ABOVE BY NO. REQ'D FOR THIS GROUP GIVEN ON INDEX SHEET

PARTS LIST

ATLAS IMPERIAL DIESEL ENGINE CO.
 OAKLAND, CALIF. MATTOON, ILL.

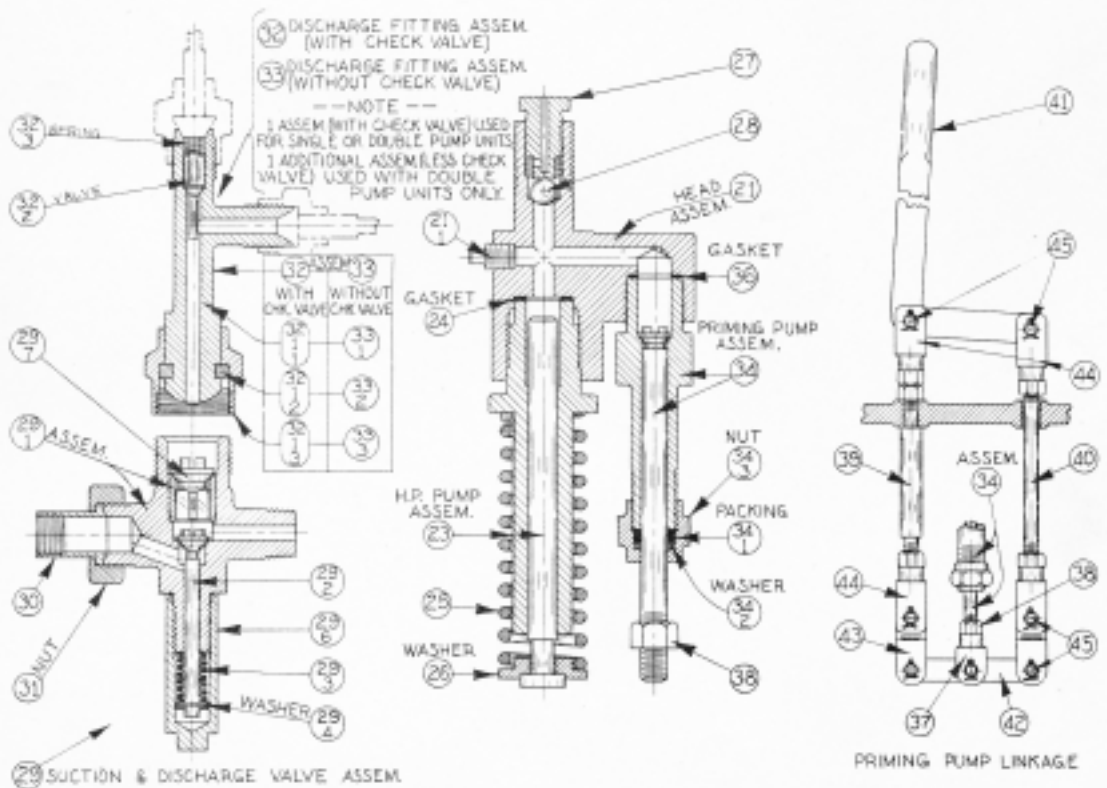
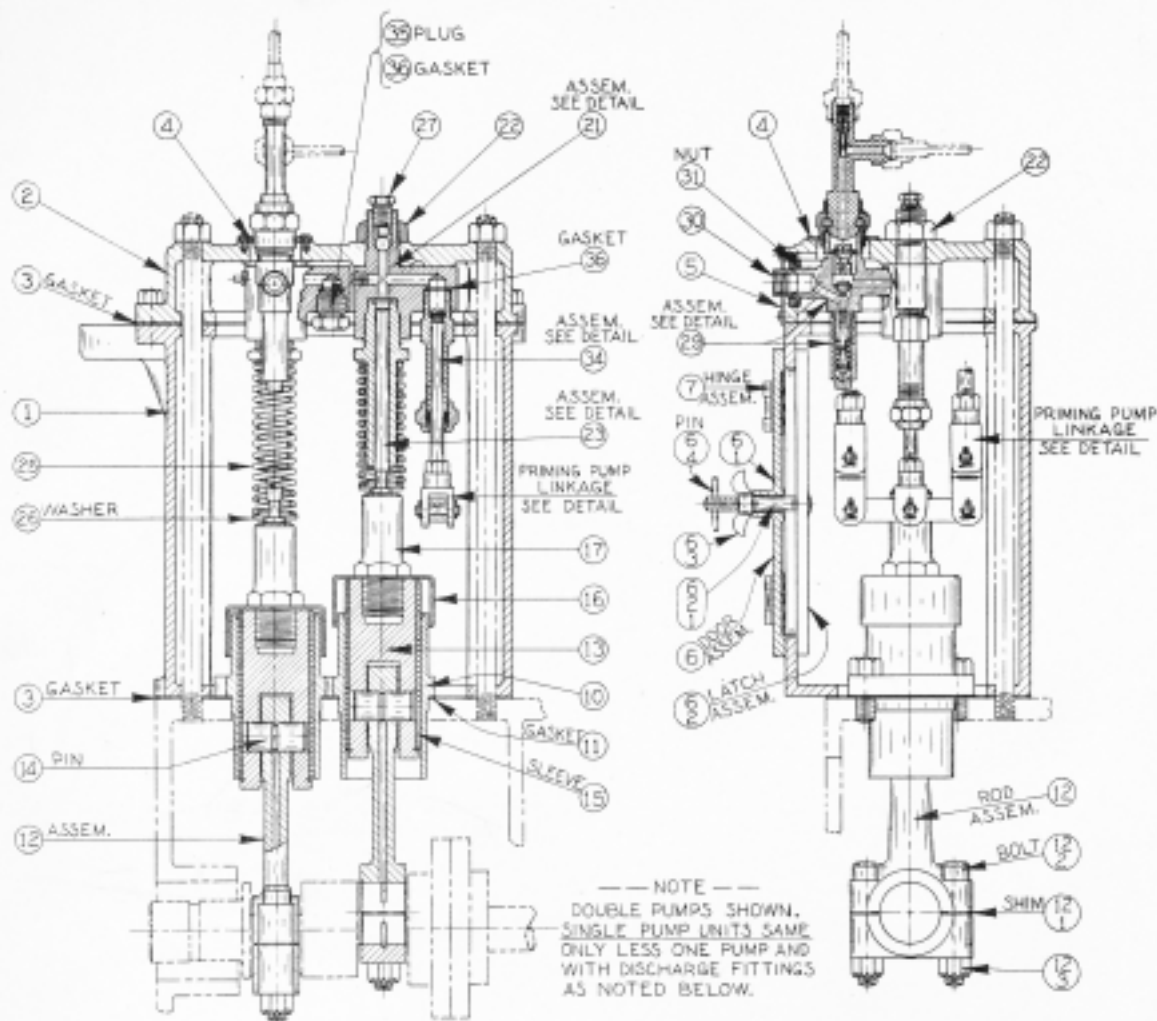

#1 Retyped From 12-19-40 - H.P.F. Pump Assem. Was X5352 - Added Part Nos. C-6222 & S-2936
 #2 9-24-41 Added Part No. 2C2160 - For Part No. 2C2119 No. Req'd. Was 1
 #3 5-17-44 Lines 31 & 33 Added Drz. Nos.
 #4 7-12-46 Line 15 Drwg. No. Added.

2L455

ALWAYS GIVE PART NUMBER-PART NAME-ENGINE NUMBER FOR STD. HARDWARE WITHOUT PART NUMBER GIVE DESCRIPTION AND SIZE * INDICATES PART NOT SERVICED INDIVIDUALLY

PLATE NO. K-2149

LINE NO.	DRWG. NO.	REF. NO. *	PART NO.	NO. REQ'D.	PART NAME	ASSEM. DRWG. NO.
1	W-926	1	846-FB4	1	HOUSING - H.P. Fuel Pump	
2	W-925	2	817-PB42	1	PLATE - H.P. Fuel Pump Mounting	
3		3	C-7916	2	GASKET - Housing & Plate	
4				4	NUT -- 5/8-11-NC-Hex. - - (St.)	
5				2	CAPSCREW -- 1/2-13-NC x 1 1/4 Lg. - (St.)	
6		4	S-1255	2	COVER - Pump Mounting Plate (Top)	
7		5	S-679	2	COVER - Pump Mounting Plate (Side)	
8				10	MACHINE SCREW--#10-24 x 3/8 Lg.-Rnd.Hd. -(St.)	
9		6	G847-FB4	1	DOOR ASSEM. - H.P. Fuel Pump Housing	
10	C-6651	7	G847C-RB3	2	HINGE ASSEM. - Pump Housing Door	
11				12	MACHINE SCREW--#10-32 x 1/2 Lg.-Flat Hd.-(St.)	
12	C-554	10	829-RB31	2	GUIDE - H.P. Fuel Pump Crosshead	
13		11	C-3055	2	GASKET - Crosshead Guide	
14				4	CAPSCREW -- 5/8-11-NC x 1 1/2 Lg. - (St.)	
15	F-7718	12	G823-RB3	2	ROD ASSEM. - Fuel Pump Connect.	
16	C-552	13	831-RB3	2	CROSSHEAD - Fuel Pump Connect. Rod	
17	S-553	14	828C-RB3	2	PIN - Connect. Rod to Crosshead	
18	C-553	15	831C-RB3	2	SLEEVE - Crosshead	
19	S-878	16	831D-RB31	2	GUARD - Crosshead Oil	
20		17	C-7905	2	PLUG - Crosshead	
21						
22		21	X3225	2	HEAD ASSEM. - H.P. Fuel Pump	
23		22		2	NUT -- 1-14-NF-Hex. - - (St.)	
24		23	X5353	2	PUMP ASSEM. - H.P. Fuel	
25		24	S-2882	2	GASKET - Pump Body to Head	
26		25	C-6222	2	SPRING - Pump Plunger	
27		26	S-2936	2	WASHER - Spring Retainer	
28		27	C-8875	2	PLUG - Fuel Pump Bleeder	
29		28		2	STEEL BALL -- 7/16 Dia. - (St.)	
30	F-5832	29	X2605	2	CAGE ASSEM.-H.P. Fuel Pump Suction & Disch. Valve	
31	2C3944	30	802B-E	2	UNION SLEEVE	
32						
33	2C3943	31	802A-E	2	UNION NUT	
34						
35		32	G796-EB32	1	FITTING ASSEM.-Pump Discharge(With Check Valve)	
36		33	G796-E	1	FITTING ASSEM. - Pump Discharge	
37		34	X3227	1	PUMP ASSEM. - Fuel Priming	
38		35	2C2160	1	PLUG - Pump Head (Priming Pump Hole)	
39		36	2C2119	2	GASKET - Priming Pump & Plug to Head	
40	S-2592	37	1279-RB3	1	EYE - Priming Pump Plunger	
41		38		1	NUT -- 7/16-20-NF-Hex. - (St.)	
42	S-3364	39	1284A-RB3	1	ROD - Handle & Link Fulcrum	
43	S-3365	40	1284-RB3	1	ROD - Link & Handle Connecting	
44	F-2274	41	1281-RB3	1	HANDLE - Priming Pump	
45	C-175	42	1280-RB3	1	LINK - Pump Plunger to Rod Connect.	
46	S-2603	43	1279A-RB3	2	LINK - Plunger Link to Rod Eye	
47	S-218	44	1279B-RB3	4	EYE - Connect. Rod & Fulcrum Rod	
48				4	NUT -- 1/2-13-NC-Hex. - (St.)	
49	S-2626	45	1280A-RB3	7	PIN - Eye to Links & Handle	
50				14	COTTER PIN -- 3/32 x 3/4 Lg. - (St.)	

2L455

FOR OFF. HAND BLE 2L456 FOR OFF. ROT. SEC

NAME FUEL PUMP GROUP

ORIGINALLY ISSUED FOR 4 CYL. 7 1/2 x 10 1/2 -- 9 x 12 -R.H.

FOR TOTAL REQUIREMENTS PER ENGINE MULTIPLY NO. REQ'D GIVEN ABOVE BY NO. REQ'D FOR THIS GROUP GIVEN ON INDEX SHEET

PARTS LIST

ATLAS IMPERIAL DIESEL ENGINE CO. OAKLAND, CALIF. MATTOON, ILL.

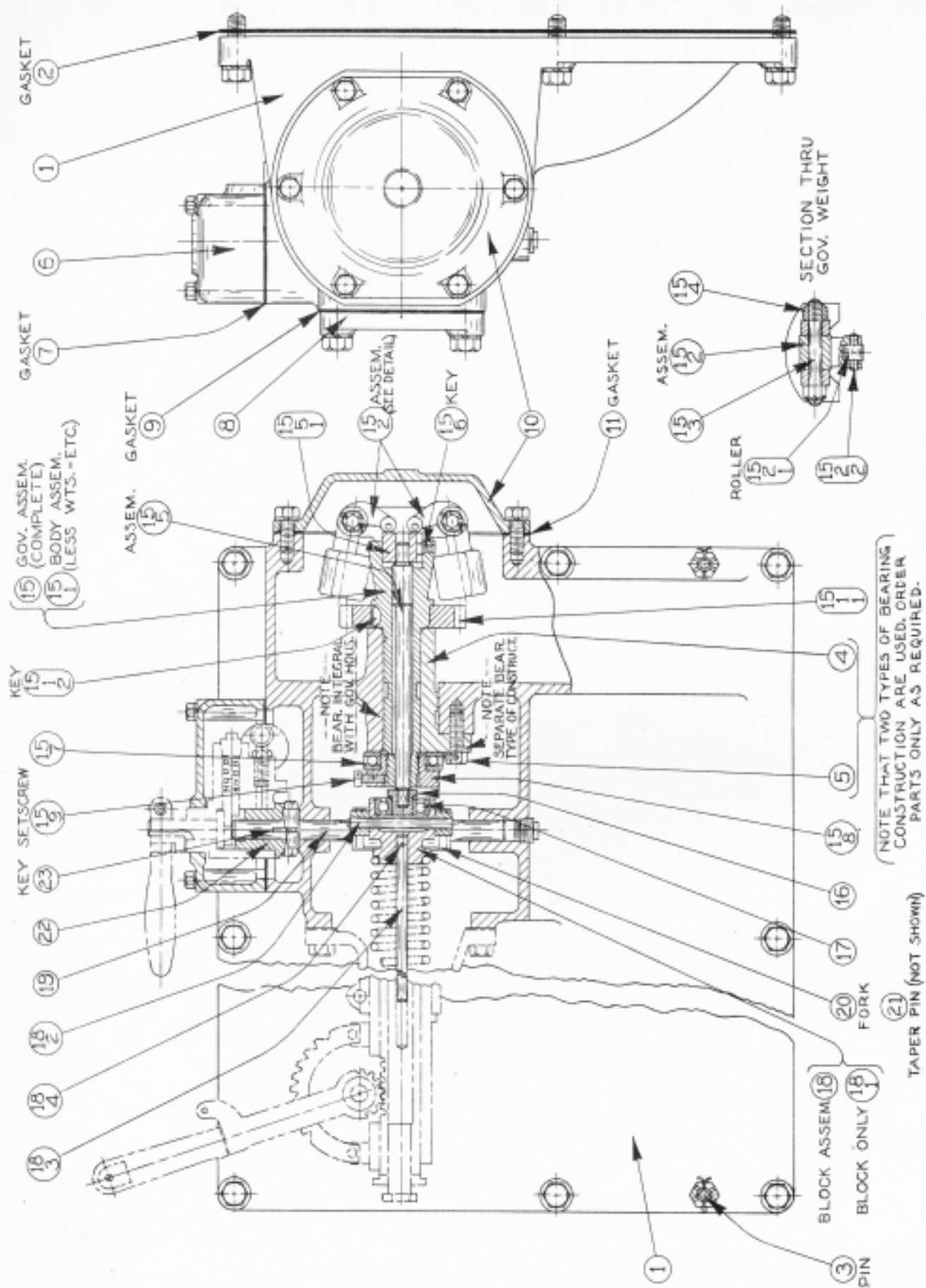

NOTE THAT TWO TYPES OF BEARING CONSTRUCTION ARE USED. ORDER PARTS ONLY AS REQUIRED.

PLATE NO.
W-2129

DO NOT ORDER PARTS BY REF. NUMBERS

CHANGES

CHANGES

ALWAYS GIVE PART NUMBER - PART NAME - ENGINE NUMBER
FOR STD. HARDWARE WITHOUT PART NUMBER GIVE DESCRIPTION AND SIZE
* INDICATES PART NOT SERVICED INDIVIDUALLY

2L865

PLATE NO. W-2129

LINK NO.	DRWG. NO.	REF. NO. *	PART NO.	NO. REQ'D.	PART NAME	ASSEM. DRWG. NO. K-730
1		1	K-1294	1	HOUSING - Governor	
2		2	S-2363	1	GASKET - Housing to Centerframe	
3				8	CAPSCREW -- 1/2-13-NC x 1 1/2 Lg. - (St.)	
4				8	LOCKWASHER -- 1/2 SAE Reg. - - (St.)	
5	C-7950	3	C-7950L1 3/4	2	PIN - Housing to Centerframe Dowel	
6				2	CASTLE NUT -- 3/8-24-NF-Hex. - - (St.)	
7				2	COTTER PIN -- 3/32 x 3/4 Lg. - (St.)	
8				1	PIPE PLUG -- 1/2 Std. - - (C.I.)	
9		6	S-3206	1	COVER - Governor Housing Top	
10		7	S-868	1	GASKET - Cover to Housing	
11				4	CAPSCREW -- 1/4-20-NC x 2 1/2 Lg. - (St.)	
12				4	LOCKWASHER -- 1/4 SAE Reg. - - (St.)	
13		8	C-1477	1	DOOR - Governor Housing (Side)	
14		9	C-1544	1	GASKET - Door to Housing	
15				4	CAPSCREW -- 1/2-13-NC x 1 1/4 Lg. - (St.)	
16				4	LOCKWASHER -- 1/2 SAE Reg. - - (St.)	
17		10	W-130	1	COVER - Governor Housing End	
18		11	C-3827	1	GASKET - Cover to Housing	
19				6	CAPSCREW -- 3/8-16-NC x 1 Lg. - (St.)	
20				6	LOCKWASHER -- 3/8 SAE Reg. - - (St.)	
21		15	X3484	1	GOVERNOR ASSEMBLY	
22		16	C-547	1	SOCKET - Thrust Quill	
23	C-9858	17	5868	1	BALL BEARING	
24	C-9799	18	X1810	1	BLOCK ASSEM. - Governor Spring	
25		19	S-3199	1	SHAFT - Governor Verticle	
26		20	F-3047	1	FORK - Governor	
27				1	CAPSCREW -- 3/8-16-NC x 1 1/4 Lg. - (St.)	
28		21		1	TAPER PIN -- #3 x 1 1/2 Lg. - (St.)	
29		22	S-3208	1	BUSHING - Governor Lever Drive	
30				1	CAPSCREW -- 3/8-24-NF x 1 1/2 Lg. - (St.)	
31				1	NUT -- 3/8-24-NF-Hex. - - (St.)	
32		23		1	WOODRUFF KEY -- 1/8 x 5/8 Std. - (St.)	
33						
34						
35						
36						
37						
38						
39						
40						
41						
42						
43						
44						
45						
46						
47						
48						
49						
50						

FOR OFF. HAND SEE

2L866

FOR OFF. NOT. SEE

NAME GOVERNOR GROUP

ORIGINALLY ISSUED FOR 3-4 CYL. 9 x 12 MARINE - R.H.

FOR TOTAL REQUIREMENTS PER ENGINE MULTIPLY NO. REQ'D GIVEN ABOVE BY NO. REQ'D FOR THIS GROUP GIVEN ON INDEX SHEET

PARTS LIST

ATLAS IMPERIAL DIESEL ENGINE CO.
OAKLAND, CALIF. MATTOON, ILL.

2L865

CHANGES

CHANGES

2L1381

PLATE NO. W-2109 (Ed 2)

ALWAYS GIVE PART NUMBER—PART NAME—ENGINE NUMBER
FOR STD. HARDWARE WITHOUT PART NUMBER GIVE DESCRIPTION AND SIZE
* INDICATES PART NOT SERVICED INDIVIDUALLY

LINE NO.	DRWG. NO.	REP. NO.	PART NO.	NO. REQD.	PART NAME	ASSEM. DRWG. NO.
1		1	X3834	1	PUMP ASSEM. - Centrif. Water	
2	C-7953	2	C-7953-B	1	SHIM - Pump to Base (1/32)	
3	C-7953	2	C-7953-D	2	SHIM - Pump to Base (.010)	
4	C-7953	2	C-7953-E	4	SHIM - Pump to Base (.003)	
5				2	CAPSCREW -- 1/2-13-NC x 1 1/4 Lg. - (St.)	
6		3A	F-7401	1	COUPLING - Pump Shaft to Drive Shaft	
7	C-6803	3B	C-6803L1 1/4	2	KEY - Coupling to Pump & Drive Shaft	
8						
9						
10					---- Pump Suction Fittings ----	
11				1	NIPPLE -- 1 1/4 x 2 1/2 Lg. - (Brass)	
12	2C155	4	2C155-P1 1/4	1	SWING CHECK VALVE	
13						
14						
15						
16						
17						
18						
19						
20						
21						
22						
23						
24						
25						
26						
27						
28						
29						
30						
31						
32						
33						
34						
35						
36						
37						
38						
39						
40						
41						
42						
43						
44						
45						
46						
47						
48						
49						
50						

NAME CENTRIFUGAL WATER PUMP GROUP - - - (1 1/4")
 ORIGINALLY ISSUED FOR 3-4 CYL. 7 1/2 - 8 x 10 1/2 MARINE
 FOR TOTAL REQUIREMENTS PER ENGINE MULTIPLY NO. REQ'D GIVEN ABOVE BY NO. REQ'D FOR GROUP GIVEN ON INDEX SHEET

PARTS LIST ATLAS IMPERIAL DIESEL ENGINE CO.
 OAKLAND, CALIF. MATTOON, ILL.

2L1381

FOR OFF. HAND. SEE
 FOR OFF. BOT. SEE
 PRINTED IN U.S.A.
 FORM 240 REV. 3-44 14 12 1945

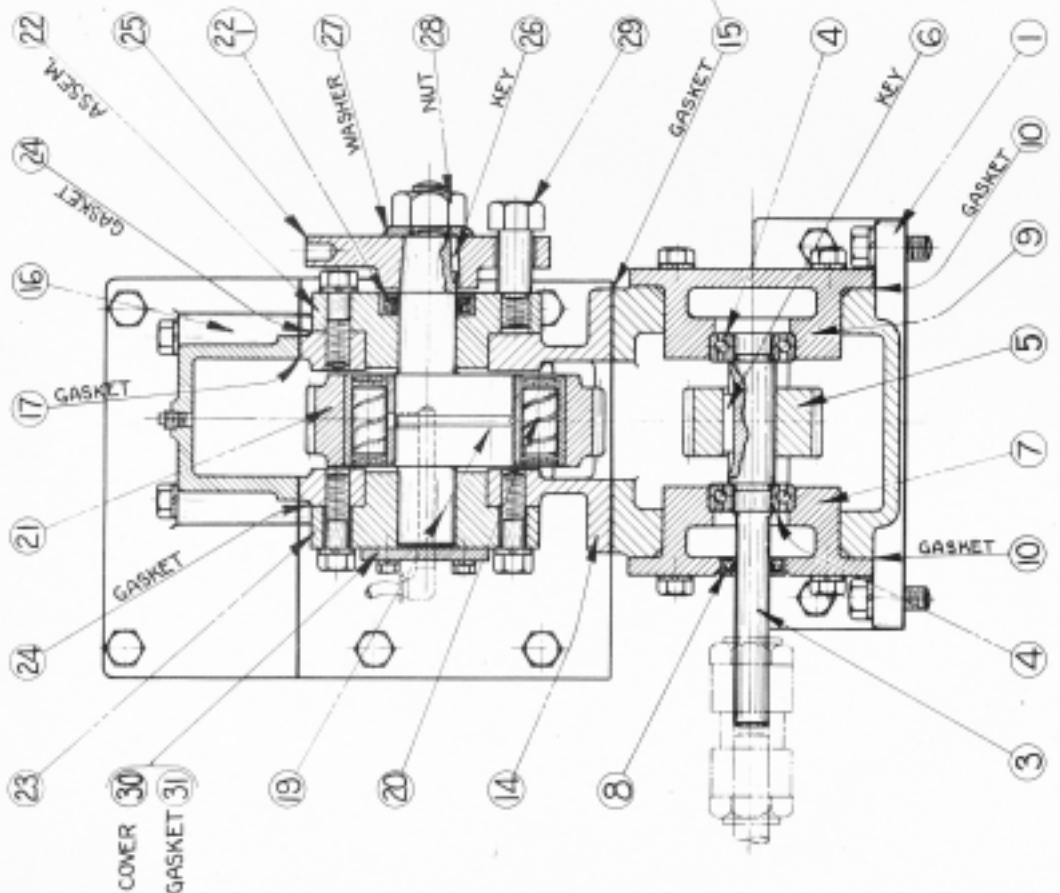
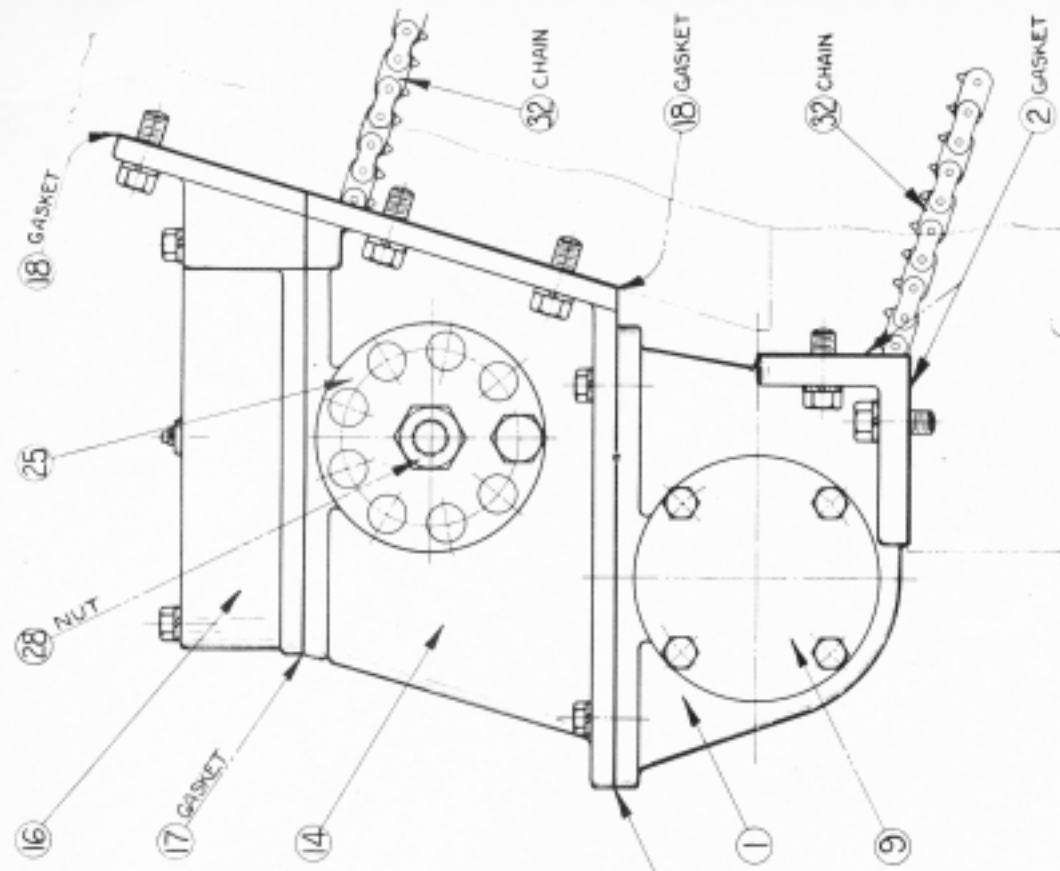

PLATE No. W-2280 DO NOT ORDER PARTS BY REF. NUMBERS

#1 4-1-47 Line 5 Part No. was 2C4155

CHANGES

CHANGES

2L1384

ALWAYS GIVE PART NUMBER—PART NAME—ENGINE NUMBER
FOR STD. HARDWARE WITHOUT PART NUMBER GIVE DESCRIPTION AND SIZE
* INDICATES PART NOT SERVICED INDIVIDUALLY

PLATE NO. W-2280

LINE NO.	DRWG. NO.	REF. NO.	PART NO.	NO. REQD.	PART NAME	ASSEM. DRWG. NO.
1		1	F-5453	1	BEARING - Centrif. Pump Drive	
2		2	C-8377	1	GASKET - Bearing to Base	
3				4	CAPSCREW -- 1/2-13-NC x 1 1/4 Lg. - (St.)	
4				4	LOCKWASHER -- 1/2 SAE Reg. - - (St.)	
5		3	2C5243	1	SHAFT - Centrif. Pump Drive	
6	C-9854	4	5988	2	BALL BEARING	
7	C-6639	5	1307-E	1	SPROCKET - Centrif. Pump Drive	
8	C-6704	6	C-6704L1 1/4	1	KEY - Centrif. Pump Drive Sprocket to Shaft	
9		7	F-5450	1	CAGE - Drive Shaft Brg.	
10		8		1	OIL SEAL -- National Motor Brg. Co. #50141	
11		9	F-5458	1	CAGE - Drive Shaft Brg. (Blind)	
12		10	S-2512	2	GASKET - Brg. Cage to Drive Brg.	
13				8	CAPSCREW -- 3/8-16-NC x 7/8 Lg. - (St.)	
14				8	LOCKWASHER -- 3/8 SAE Reg. - - (St.)	
15						
16						
17		14	F-5446	1	HOUSING - Cent. Pump Chain Idler	
18		15	S-2510	1	GASKET - Housing to Pump Drive Bearing	
19				4	CAPSCREW -- 3/8-16-NC x 1 Lg. - (St.)	
20				4	LOCKWASHER -- 3/8 SAE Reg. - - (St.)	
21		16	F-5447	1	COVER - Chain Idler Housing Top	
22		17	C-8361	1	GASKET - Cover to Housing	
23				4	CAPSCREW -- 3/8-16-NC x 3 1/4 Lg. - (St.)	
24				4	LOCKWASHER -- 3/8 SAE Reg. - - (St.)	
25		18	C-8362	1	GASKET - Idler Hous. & Cover to Centerframe	
26				6	CAPSCREW -- 1/2-13-NC x 1 1/4 Lg. - (St.)	
27				6	LOCKWASHER -- 1/2 SAE Reg. - - (St.)	
28				1	PIPE PLUG -- 1/8 Std. - - (C.I.)	
29		19	F-2097	1	SHAFT - Chain Idler	
30		20	C-5288	1	BEARING - Chain Idler Sprocket (Hyatt W-213)	
31		21	F-909	1	SPROCKET - Chain Idler	
32		22	X2149	1	BEARING ASSEM. - Idler Shaft (Adjust. Side)	
33	F-2098	23	4098	1	BEARING - Idler Shaft	
34		24	C-5270	2	GASKET - Bearing to Idler Housing	
35				8	CAPSCREW -- 1/2-13-NC x 1 1/2 Lg. - (St.)	
36				8	LOCKWASHER -- 1/2 SAE Reg. - - (St.)	
37		25	F-3000	1	DISC - Idler Adjusting	
38	S-3137	26	5112	1	KEY - Adj. Disc to Idler Shaft	
39		27	S-3186	1	WASHER - Adj. Disc Retainer	
40		28		1	NUT -- 3/4-10-NC-Hex. - - (St.)	
41		29	S-1857	1	PIN - Adj. Disc Lock	
42	F-398	30	846B-JX	1	COVER - Idler Shaft End	
43		31	S-1060	1	GASKET - Cover to Brg.	
44				4	CAPSCREW -- 1/4-20-NC x 5/8 Lg. - (St.)	
45				4	LOCKWASHER -- 1/4 SAE Reg. - - (St.)	
46		32		1	CHAIN -- Whitney #B-207 Silent Chain - 1/2 Pitch - 138 Links Lg. - Chain to Include one Straight Connect. Link Complete	
47						
48						
49						
50						

FOR OFF. HAND REC
2L1385

FOR OFF. NOT. REC

NAME CENTRIFUGAL WATER PUMP DRIVE GROUP

ORIGINALLY ISSUED FOR 3-4 CYL. 9 x 12 MARINE - R.H.

FOR TOTAL REQUIREMENTS PER ENGINE MULTIPLY NO. REQ'D GIVEN ABOVE BY NO. REQ'D FOR GROUP GIVEN ON INDEX SHEET

PARTS LIST

ATLAS IMPERIAL DIESEL ENGINE CO.

OAKLAND, CALIF.

MATTOON, ILL.

2L1384

EXTRA COPIES TO MATTOON

TYPED BY FR DATE 10-17-46

CHKD. *ABX* ISSUED BY *APC*

DATE 10-30-46

Retyped from 12-15-42 (No Changes)

#2

CHANGES

L-4552

ALWAYS GIVE PART NUMBER—PART NAME—ENGINE NUMBER
FOR STD. HARDWARE WITHOUT PART NUMBER GIVE DESCRIPTION AND SIZEPLATE
No.

LINE NO.	DRWG. NO.	REF. NO.	PART NO.	NO. REQ'D.	PART NAME	ASSEM. DRWG. NO.
1			P-3375	1	BRACKET - Fuel Oil Day Tank	
2				3	CAPSCREW -- 3/8-16-NC x 1 Lg. - (St.)	
3				3	LOCKWASHER -- 3/8 SAE Reg. - (St.)	
4						
5						
6						
7						
8						
9						
10						
11						
12						
13						
14						
15						
16						
17						
18						
19						
20						
21						
22						
23						
24						
25						
26						
27						
28						
29						
30						
31						
32						
33						
34						
35						
36						
37						
38						
39						
40						
41						
42						
43						
44						
45						
46						
47						
48						
49						
50						

FOR OFF. HAND SEE

L-4553

FOR OFF. NOT. SEE

NAME FUEL OIL DAY TANK BRACKET GROUP

ORIGINALLY ISSUED FOR 6 1/2 x 8 1/2 - R.H.

FOR TOTAL REQUIREMENTS PER ENGINE MULTIPLY NO. REQ'D GIVEN ABOVE BY NO. REQ'D FOR GROUP GIVEN ON INDEX SHEET

PARTS LIST

ATLAS IMPERIAL DIESEL ENGINE CO.
OAKLAND, CALIF. MATTOON, ILL.FORM 240 REV. 1/45 2M TRANS.
PRINTED IN U.S.A.

L-4552

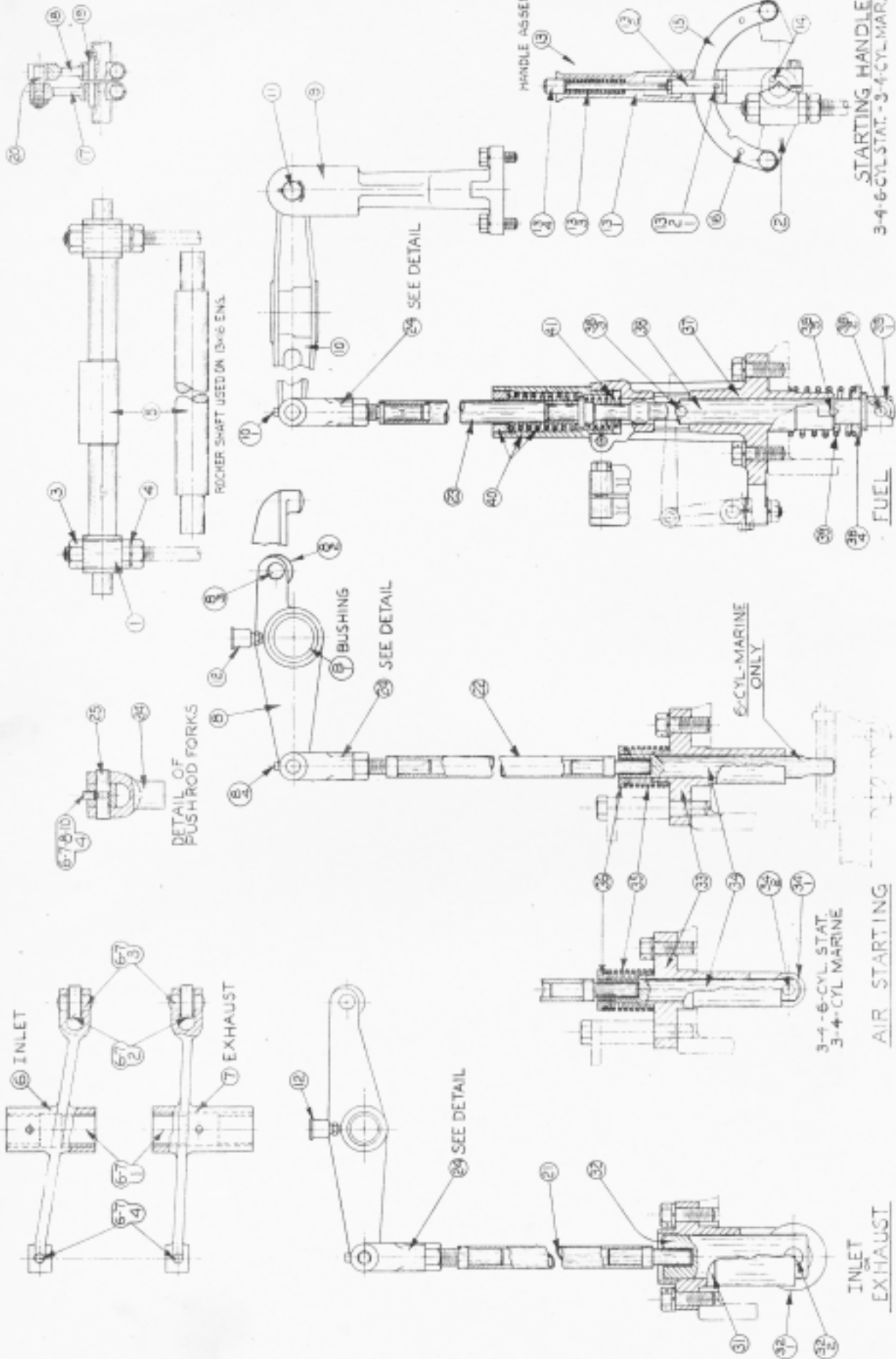

Retyped from 12-23-43 (no change)

CHANGES
6

CHANGES

L-6827

ALWAYS GIVE PART NUMBER—PART NAME—ENGINE NUMBER
FOR STD. HARDWARE WITHOUT PART NUMBER GIVE DESCRIPTION AND SIZE

PLATE No. K-192F

LINE NO.	DRWG. NO.	REF. NO.	PART NO.	NO. REQD.	PART NAME	ASSEM. DRWG. NO.
1	C-7988	31	529-C	2	GUIDE - In. & Ex. Valve Lifter	
2				4	CAPSCREW -- 5/8-11-NC x 1 3/4 Lg. - - (St.)	
3				4	LOCKWASHER -- 5/8 SAE Reg. - - (St.)	
4	C-8465	32	X1211	2	LIFTER ASSEM. - In. & Ex. Valve	
5						
6	C-7989	33	599-C	1	GUIDE - Air Start. Valve Lifter	
7				1	CAPSCREW -- 5/8-11-NC x 1 3/4 Lg. - - (St.)	
8				1	LOCKWASHER -- 5/8 SAE Reg. - - (St.)	
9	C-7531	34	G594-E	1	LIFTER ASSEM. - Air Start. Valve	
10	C-7452	35	888-C3	1	SPRING - Air Start. Valve Lifter	
11	C-7987	36	594A-E	1	COLLAR - Valve Lifter Spring Retainer	
12						
13		37	W-140	1	GUIDE - Fuel Spray Valve Lifter	
14				2	CAPSCREW -- 5/8-11-NC x 1 3/4 Lg. - - (St.)	
15				2	LOCKWASHER -- 5/8 SAE Reg. - - (St.)	
16				1	CAPSCREW (Clamp) -- 1/2-13-NC x 2 Lg. - - (St.)	
17	F-3238	38	X489	1	LIFTER ASSEM. - Fuel Spray Valve	
18		39	C-3291	1	SPRING - Fuel Spray Valve Lifter	
19						
20	C-1932	40	X490	1	SPRING ASSEM. - Spray Valve Push-Rod Buffer	
21		41	C-1933	1	SPRING - Spray Valve Push-Rod	
22						
23						
24						
25						
26						
27						
28						
29						
30						
31						
32						
33						
34						
35						
36						
37						
38						
39						
40						
41						
42						
43						
44						
45						
46						
47						
48					---- Cross-Reference Note ----	
49					For L.H. See L-7558	
50					For L.H. 6 Cyl. 10 x 13 with Wood. Gov. See 2L1104	

FOR OFF. HAND SEE

SEE NOTE

FOR OFF. NOT. SEE

NAME VALVE LIFTER & GUIDE GROUP

ORIGINALLY ISSUED FOR 3-4 CYL. 7x10 1/2 to 13x16 R.H.

FOR TOTAL REQUIREMENTS PER ENGINE MULTIPLY NO. REQ'D GIVEN ABOVE BY NO. REQ'D FOR GROUP GIVEN ON INDEX SHEET

PARTS LIST

ATLAS IMPERIAL DIESEL ENGINE CO.
OAKLAND, CALIF.

MATTSON, ILL. CO.

L-6827

#5 Retyped from 10-25-34 (No changes)

CHANGES

CHANGES

L-6881

ALWAYS GIVE PART NUMBER—PART NAME—ENGINE NUMBER
FOR STD. HARDWARE WITHOUT PART NUMBER GIVE DESCRIPTION AND SIZE
* INDICATES PART NOT SERVICED INDIVIDUALLYPLATE
NO.

LINE NO.	DRWG. NO.	REF. NO.	PART NO.	NO. REQD.	PART NAME	ASSEM. DRWG. NO.
1	2C4040		1217-AX3	1	GAGE - Fuel Pressure	
2	2C46		5898	1	GAGE - Lube Oil Pressure	
3				6	MACHINE SCREW -- 1/4-20 x 3/8 Lg.Rnd.Hd.(St.)	
4						
5			X2071	2	BRACKET ASSEM. - Pressure Gage	
6						
7						
8						
9						
10						
11						
12						
13						
14						
15						
16						
17						
18						
19						
20						
21						
22						
23						
24						
25						
26						
27						
28						
29						
30						
31						
32						
33						
34						
35						
36						
37						
38						
39						
40						
41						
42						
43						
44						
45						
46						
47						
48						
49						
50						

FOR OFF HAND SEE

FOR OFF. REV. SEE

NAME PRESSURE GAGE GROUP

ORIGINALLY ISSUED FOR 3-4 CYL. 7 $\frac{1}{2}$ -8 x 10 $\frac{1}{2}$ MAR.-STAT.

FOR TOTAL REQUIREMENTS PER ENGINE MULTIPLY NO. REQ'D GIVEN ABOVE BY NO. REQ'D FOR GROUP GIVEN ON INDEX SHEET

PARTS LIST

ATLAS IMPERIAL DIESEL ENGINE CO.
OAKLAND, CALIF. MATTOON, ILL.

L-6881

MASTER PARTS

EXTRA COPIES TO

URL-M

TYPED BY PR

DATE 9/11/46

CHKD

ISSUED BY

DATE

9-12-46

Retyped from C-9-45 (No Changes)

CHANGES #6

CHANGES

L-700L

PLATE No. K-2356(See Note)

ALWAYS GIVE PART NUMBER—PART NAME—ENGINE NUMBER FOR STD. HARDWARE WITHOUT PART NUMBER GIVE DESCRIPTION AND SIZE

LINE NO.	DRWG. NO.	REF. NO.	PART NO.	NO. REQD.	PART NAME	ASSEM. DRWG. NO.
1		51	P-4246	1	CAM - Inlet & Air Starting	
2	2C1432	57	2C1432L5 1/2	1	KEY - Cam to Camshaft	
3		58	P-4248	1	CAM - Exhaust	
4	S-2978	61	881-E	1	DISC - Spray Valve Cam	
5	C-2408	62	C-2408L1 1/2	2	CAPSCREW - Disc To Ex. Cam	
6	S-2233	63	881A-E	2	WASHER - Disc to Cam Capscrew	
7	F-1856	64	880-E	1	TOE - Spray Valve Cam Disc	
8	C-2406	65	C-2406L 3/4	1	CAPSCREW - Toe to Cam Disc	
9				1	WIRE -- #16 Ga. x 12 Lg. - (St.)	
10	2C1432	66	2C1432L4 1/2	1	KEY - Cam to Camshaft	
11						
12						
13						
14						
15						
16						
17						
18						
19						
20						
21						
22						
23						
24						
25						
26						
27						
28						
29						
30						
31						
32						
33						
34						
35						
36						
37						
38						
39						
40						
41						
42						
43						
44						
45						
46						
47						
48						
49						
50						

---- NOTE ----

For L.H. 7 1/2-8 x 10 1/2 & 9 x 12 Engines See L-9132
 For Larger Size Engines See 2L1005.
 For corresponding Cam Group used with Gas Conversion
 See 2L1220.
 For 9 x 10 1/2 Engines use Plate No. K-1833

FOR OFF. HAND SEE
SEE NOTE
 FOR OFF. NOT. SEE
L-7002

NAME **CAM GROUP - - - (INBOARD ROTATION)**
 ORIGINALLY ISSUED FOR

FOR TOTAL REQUIREMENTS PER ENGINE MULTIPLY NO. REQ'D GIVEN ABOVE BY NO. REQ'D FOR GROUP GIVEN ON INDEX SHEET

PARTS LIST

ATLAS IMPERIAL DIESEL ENGINE CO.
 OAKLAND, CALIF. MATTOON, ILL.

L-7001

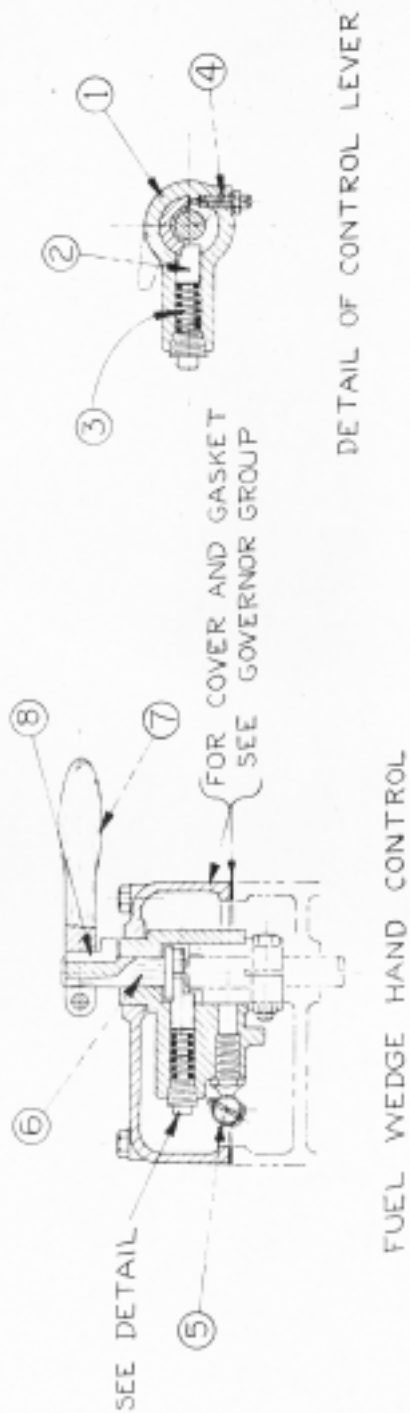
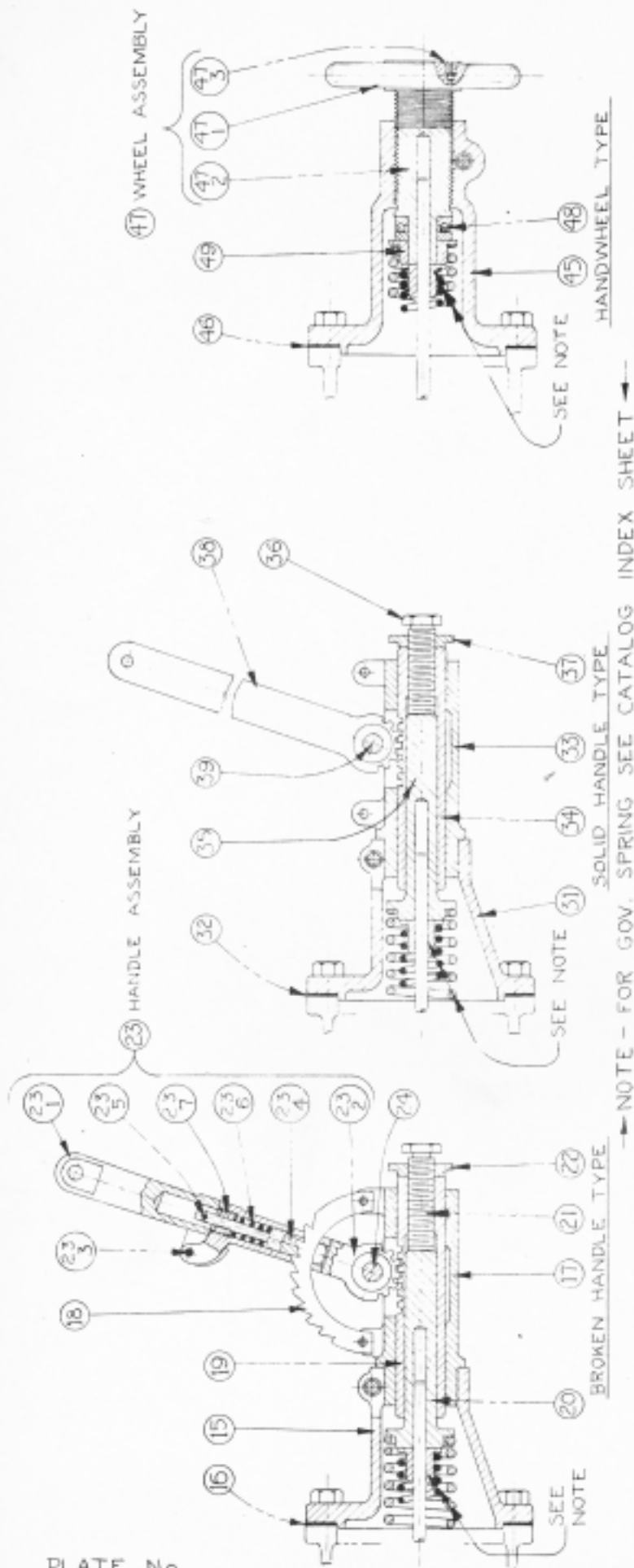

Retyped from 5-15-41 (No Changes)
#5

CHANGES

ALWAYS GIVE PART NUMBER—PART NAME—ENGINE NUMBER
FOR STD. HARDWARE WITHOUT PART NUMBER GIVE DESCRIPTION AND SIZEPLATE
No.

W-1861

L-7123

LINE NO.	DRWG. NO.	REF. NO.	PART NO.	NO. REQD.	PART NAME	ASSEM. DRWG. NO.
1		1	S-3207	1	LEVER - Wedge Shaft Control	S-3209
2		2	S-3334	1	PIN - Control Lever Drive	
3		3	S-3202	1	SPRING - Drive Pin	
4				1	PIPE PLUG -- 3/8 Std. -(Spring Retainer) - (St.)	
5		4	S-3193	1	SETSCREW - Governor Lever Stop	
6				1	HALF NUT -- 1/4-20-NC-Hex. - (St.)	
7		5	C-8410	1	JOINT - Ball & Socket	
8		6	S-3288	1	SHAFT - Wedge Control Handle	
9		7	S-819	1	HANDLE - Wedge Control	
10		8	S-3194	1	KEY - Handle	
11				1	CAPSCREW -- 5/16-18-NC x 1 1/4 Lg. - (St.)	
12						
13				1	LOCKWASHER(Ball Joint)--3/8 Shakeproof Type 12	
14						
15						
16						
17						
18						
19						
20						
21						
22						
23						
24						
25						
26						
27						
28						
29						
30						
31						
32						
33						
34						
35						
36						
37						
38						
39						
40						
41						
42						
43						
44						
45						
46						
47						
48						
49						
50						

FOR OPP. HAND SEE

L-7139

FOR OPP. ROT. SEE

NAME FUEL WEDGE HAND CONTROL GROUP

ORIGINALLY
ISSUED FOR

FOR TOTAL REQUIREMENTS PER ENGINE MULTIPLY NO. REQ'D GIVEN ABOVE BY NO. REQ'D FOR GROUP GIVEN ON INDEX SHEET

PARTS LIST

ATLAS IMPERIAL DIESEL ENGINE CO.
OAKLAND, CALIF. MATTOON, ILL.

L-7123

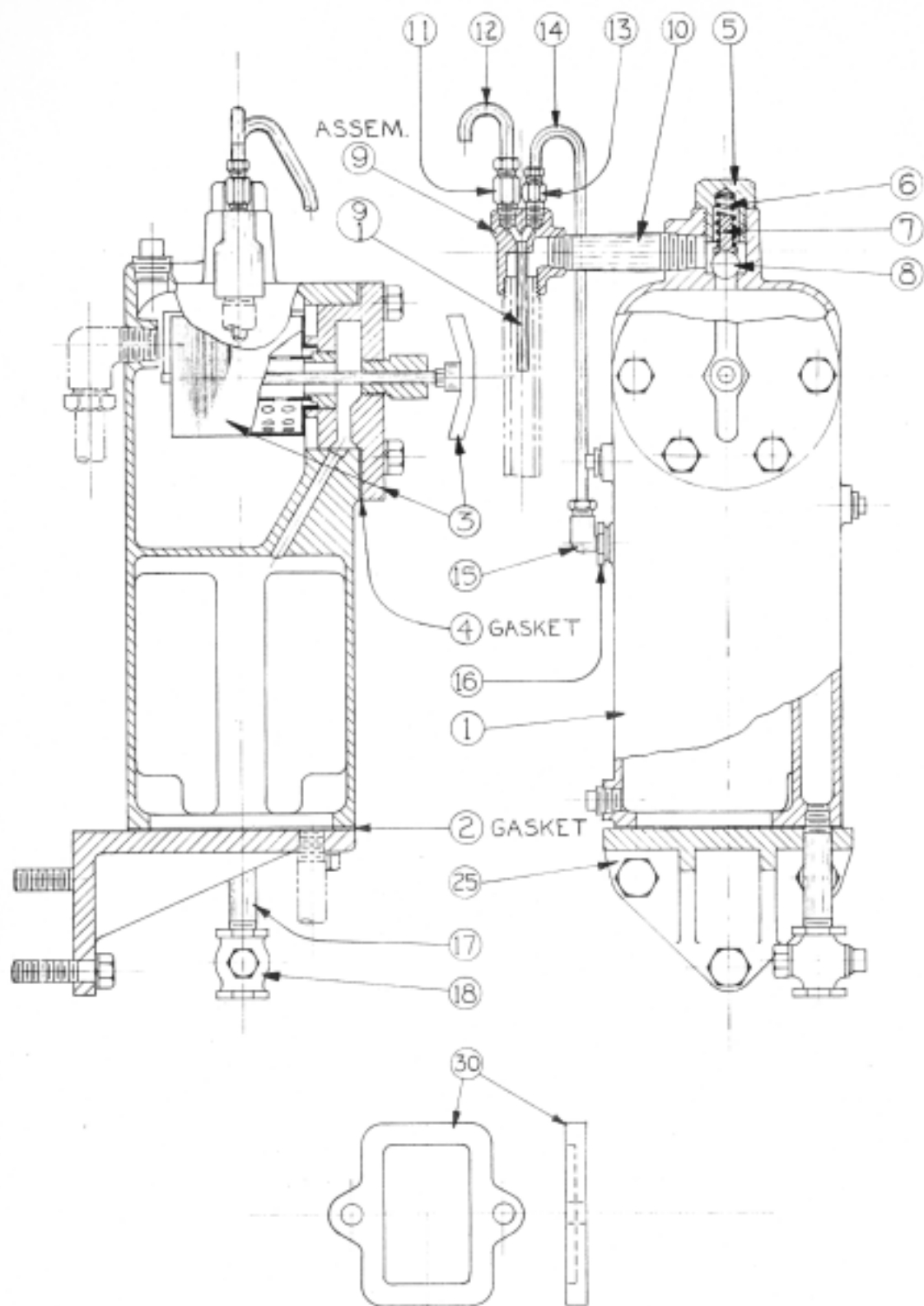

BRACKET TO CYLINDER BLOCK SPACER
7x8½ ENG. ONLY

Retyped from 5-26-41 (no change)

CHANGES #7

CHANGES

L-8011

PLATE #1842

ALWAYS GIVE PART NUMBER—PART NAME—ENGINE NUMBER
FOR STD. HARDWARE WITHOUT PART NUMBER GIVE DESCRIPTION AND SIZE

LINE NO.	DRWG. NO.	REF. NO.	PART NO.	NO. REQ'D.	PART NAME	ASSEM. DRWG. NO.
1		1	K-404	1	TANK - Fuel	3774
2				3	PIPE PLUG -- 1/4 Std. - (C.I.)	
3				1	PIPE PLUG -- 1/2 Std. - (C.I.)	
4	2	S-2346		1	GASKET - Tank to Bracket	
5				4	CAPSCREW -- 1/2-13-NC x 1 1/4 Lg. - - (St.)	
6				4	LOCKWASHER -- 1/2 SAE Reg. - - (St.)	
7	3	PG 78		1	ELEMENT - Filter	
8	4	S-1009		1	GASKET - Element to Tank	
9				6	CAPSCREW -- 1/2-13-NC x 1 1/4 Lg. - - (St.)	
10				6	LOCKWASHER -- 1/2 SAE Reg. - - (St.)	
11	5	S-2220		1	PLUG - Relief Valve Spring Retainer	
12	6	S-2345		1	SPRING - Relief Valve	
13	7	S-2673		1	SEAT - Relief Valve Spring	
14	8			1	STEEL BALL -- 5/8 Dia. Std. - - (St.)	
15						
16	9	X511		1	VENT ASSEM. - Fuel Tank	
17	10			1	NIPPLE -- 1/2 x 3 1/2 Lg. - - (St.)	
18	C-9840	11 C-9840-P 1/4		1	CHECK VALVE - (Tube Fitting)	
19		12		1	TUBE (Vent)--1/4 O.D. x .030 x 7 Lg. - (S.D.Cop.)	
20	C-9801	13 C-9801-F 1/4		1	CONNECTOR - Tube	
21		14		1	TUBE -- 1/4 O.D. x .030 x 14 1/2 Lg. - (S.D.Cop.)	
22	C-9804	15 C-9804-P 1/4		1	ELBOW - Tube	
23						
24						
25						
26						
27					--- Tank Drain ---	
28		17		1	NIPPLE -- 3/8 x 2 Lg. - (Brass)	
29	C-9053	18 C-9053-P 3/8		1	COCK - Drain	
30						
31						
32						
33						
34						
35						
36						
37						
38						
39						
40						
41						
42						
43						
44						
45						
46						
47						
48						
49						
50						

FOR OFF. HAND SEE

NAME FUEL DAY TANK GROUP

FOR OFF. NOT. SEE

ORIGINALLY
ISSUED FOR

FOR TOTAL REQUIREMENTS PER ENGINE MULTIPLY NO. REQ'D GIVEN ABOVE BY NO. REQ'D FOR GROUP GIVEN ON INDEX SHEET

FORM 240 REV. 1/48 24 TRAKS.
PRINTED IN U.S.A.

PARTS LIST

ATLAS IMPERIAL DIESEL ENGINE CO.
OAKLAND, CALIF. MATTOON, ILL.

L-8011

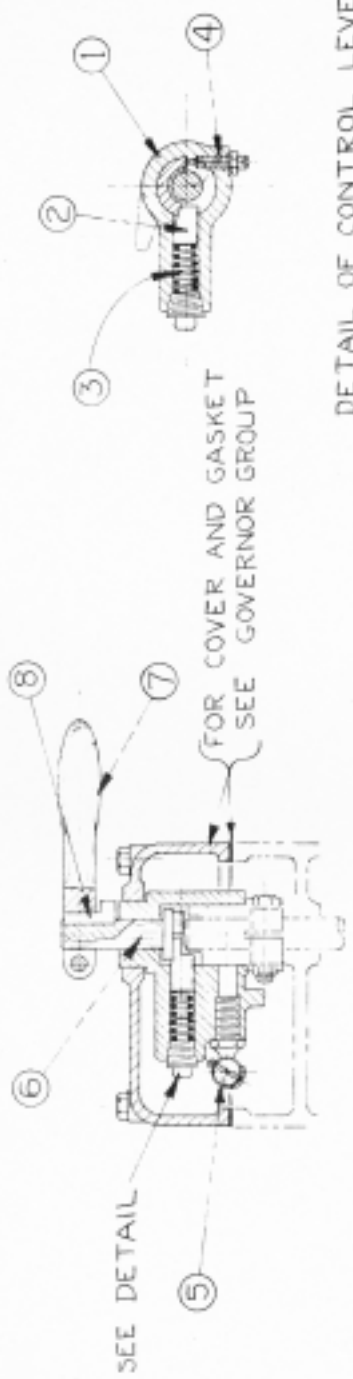
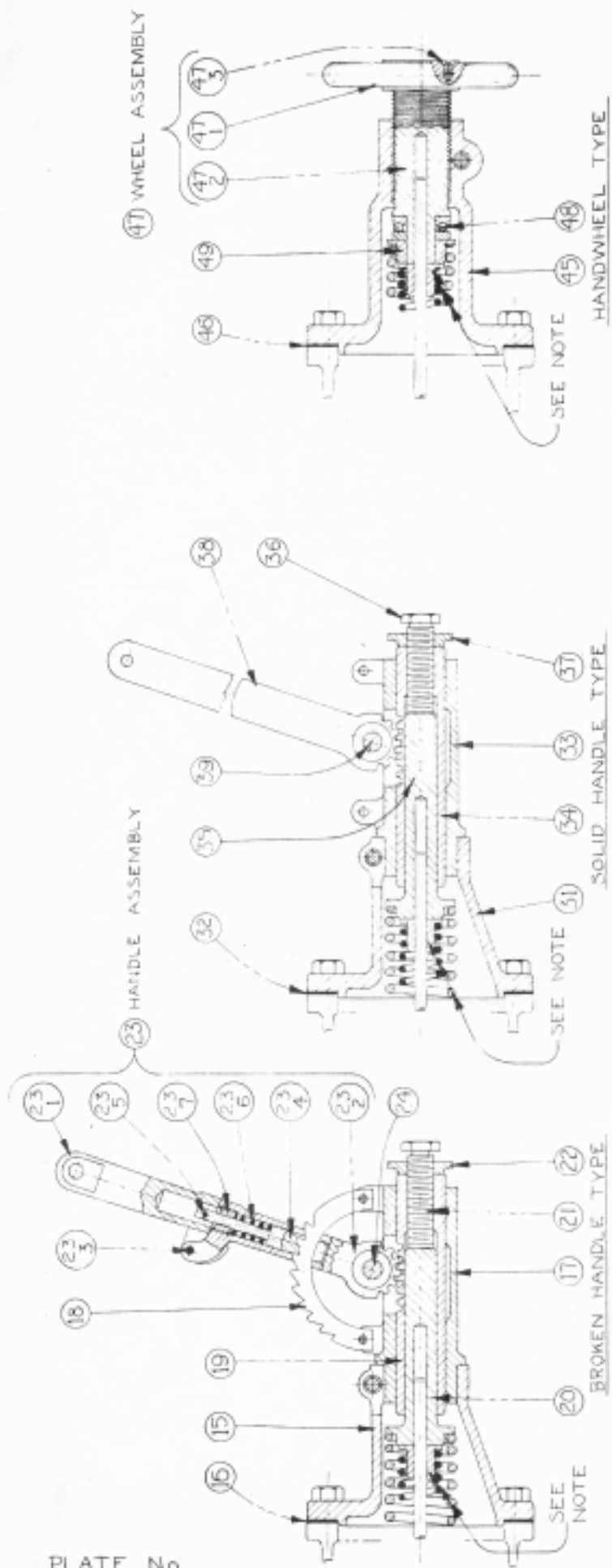

Retyped from 6-19-45 (no change)

CHANGES
4

CHANGES

L-8074

PLATE No. W-1861

ALWAYS GIVE PART NUMBER—PART NAME—ENGINE NUMBER
FOR STD. HARDWARE WITHOUT PART NUMBER GIVE DESCRIPTION AND SIZE

LINE NO.	DRWG. NO.	REF. NO.	PART NO.	NO. REQ'D.	PART NAME,	ASSEM. DRWG. NO.
1	F-6032	15	1123-DXC4	1	BEARING - Spring Control Rack Guide	F-5042
2		16	S-867	1	GASKET - Bearing to Gov. Housing	
3				4	CAPSCREW -- 1/2-13-NC x 1 1/4 Lg. - - (St.)	
4				4	LOCKWASHER -- 1/2 SAE Reg. - - (St.)	
5				1	CAPSCREW (Clamp) -- 3/8-16-NC x 2 Lg. - - (St.)	
6		17	P-2661	1	GUIDE - Spring Control Rack	
7	S-1932	18	1122A-E1	1	SECTOR - Control Handle	
8				2	CAPSCREW -- 1/4-20-NC x 1 Lg. - - (St.)	
9				2	NUT -- 1/4-20-NC-Hex. - - (St.)	
10				2	LOCKWASHER -- 1/4 SAE Reg. - - (St.)	
11		19	S-2945	1	RACK - Spring Control	
12		20	S-2907	1	GUIDE - Gov. Spring	
13		21	C-8271	1	SCREW - Gov. Spring Adjust.	
14		22	C-8272	1	NUT - Adjust. Screw Lock	
15		23	X5227	1	HANDLE ASSEM. - Gov. Control	
16		24		1	CAPSCREW -- 1/2-13-NC x 2 Lg. - - (St.)	
17		24		2	HALF NUT -- 1/2-13-NC-Hex. - - (St.)	
18						
19						
20						
21						
22						
23						
24						
25						
26						
27						
28						
29						
30						
31						
32						
33						
34						
35						
36						
37						
38						
39						
40						
41						
42						
43						
44						
45						
46						
47						
48						
49						
50						

FOR OPP. HANDS

FOR OPP. ROT. SEC

FORM 240 REV. 1/4/45 TRANS.
PRINTED IN U.S.A.

NAME GOVERNOR CONTROL GROUP - - - (BROKEN HANDLE)

ORIGINALLY
ISSUED FOR

FOR TOTAL REQUIREMENTS PER ENGINE MULTIPLY NO. REQ'D GIVEN ABOVE BY NO. REQ'D FOR GROUP GIVEN ON INDEX SHEET

PARTS LIST

ATLAS IMPERIAL DIESEL ENGINE CO.
OAKLAND, CALIF. MATTOON, ILL.

L-8074

#1 Retyped From 5-13-36 (No Changes)

CHANGES

CHANGES

L-8076

ALWAYS GIVE PART NUMBER - PART NAME - ENGINE NUMBER
 FOR STD. HARDWARE WITHOUT PART NUMBER GIVE DESCRIPTION AND SIZE
 * INDICATES PART NOT SERVICED INDIVIDUALLY

PLATE NO. SEE GOV. CONTROL

LINE NO.	DRWG. NO.	REF. NO. *	PART NO.	NO. REQD.	PART NAME	ASSEM. DRWG. NO.
1			C-6234	1	SPRING - Governor Inner	
2			C-6283	2	GUIDE - Governor Spring	
3						
4						
5						
6						
7						
8						
9						
10						
11						
12						
13						
14						
15						
16						
17						
18						
19						
20						
21						
22						
23						
24						
25						
26						
27						
28						
29						
30						
31						
32						
33						
34						
35						
36						
37						
38						
39						
40						
41						
42						
43						
44						
45						
46						
47						
48						
49						
50						

FOR OPP. HAND SEE

FOR OPP. ROT. SEE

NAME GOVERNOR SPRING - - (INNER)

ORIGINALLY ISSUED FOR

FOR TOTAL REQUIREMENTS PER ENGINE MULTIPLY NO. REQ'D GIVEN ABOVE BY NO. REQ'D FOR THIS GROUP GIVEN ON INDEX SHEET

PARTS LIST

ATLAS IMPERIAL DIESEL ENGINE CO.
 OAKLAND, CALIF. MATTOON, ILL.

L-8076

EXTRA COPIES TO

TYPED BY FR

DATE

10-17-46

CHKD.

ISSUED BY

DATE

10-23-46

Retyped from 5-19-45 (No Changes)

#1

CHANGES

CHANGES

L-8205

ALWAYS GIVE PART NUMBER—PART NAME—ENGINE NUMBER
FOR STD. HARDWARE WITHOUT PART NUMBER GIVE DESCRIPTION AND SIZE

PLATE No. SEE WEDGE SHAFT

LINE NO.	DRWG. NO.	REF. NO.	PART NO.	NO. REQD.	PART NAME	ASSEM. DRWG. NO.
1	C-43	40	1135-E-L.H.	1	SPRING - Fuel Wedge Shaft	
2	S-858	41	1136-E	1	CLAMP - Wedge Shaft Spring	
3				1	CAPSCREW -- 1/4-20-NC x 1 Lg. - (St.)	
4						
5						
6						
7						
8						
9						
10						
11						
12						
13						
14						
15						
16						
17						
18						
19						
20						
21						
22						
23						
24						
25						
26						
27						
28						
29						
30						
31						
32						
33						
34						
35						
36						
37						
38						
39						
40						
41						
42						
43						
44						
45						
46						
47						
48						
49						
50						

FOR OFF. HAND SEE

L-8204

FOR OFF. ROT. SEE

NAME FUEL WEDGE SHAFT SPRING GROUP

ORIGINALLY
ISSUED FOR

FOR TOTAL REQUIREMENTS PER ENGINE MULTIPLY NO. REQ'D GIVEN ABOVE BY NO. REQ'D FOR GROUP GIVEN ON INDEX SHEET.

PARTS LIST

ATLAS IMPERIAL DIESEL ENGINE CO.
OAKLAND, CALIF. MATTOON, ILL.FORM 240 REV. 1/24 2M TRANS.
PRINTED IN U.S.A.

L-8205

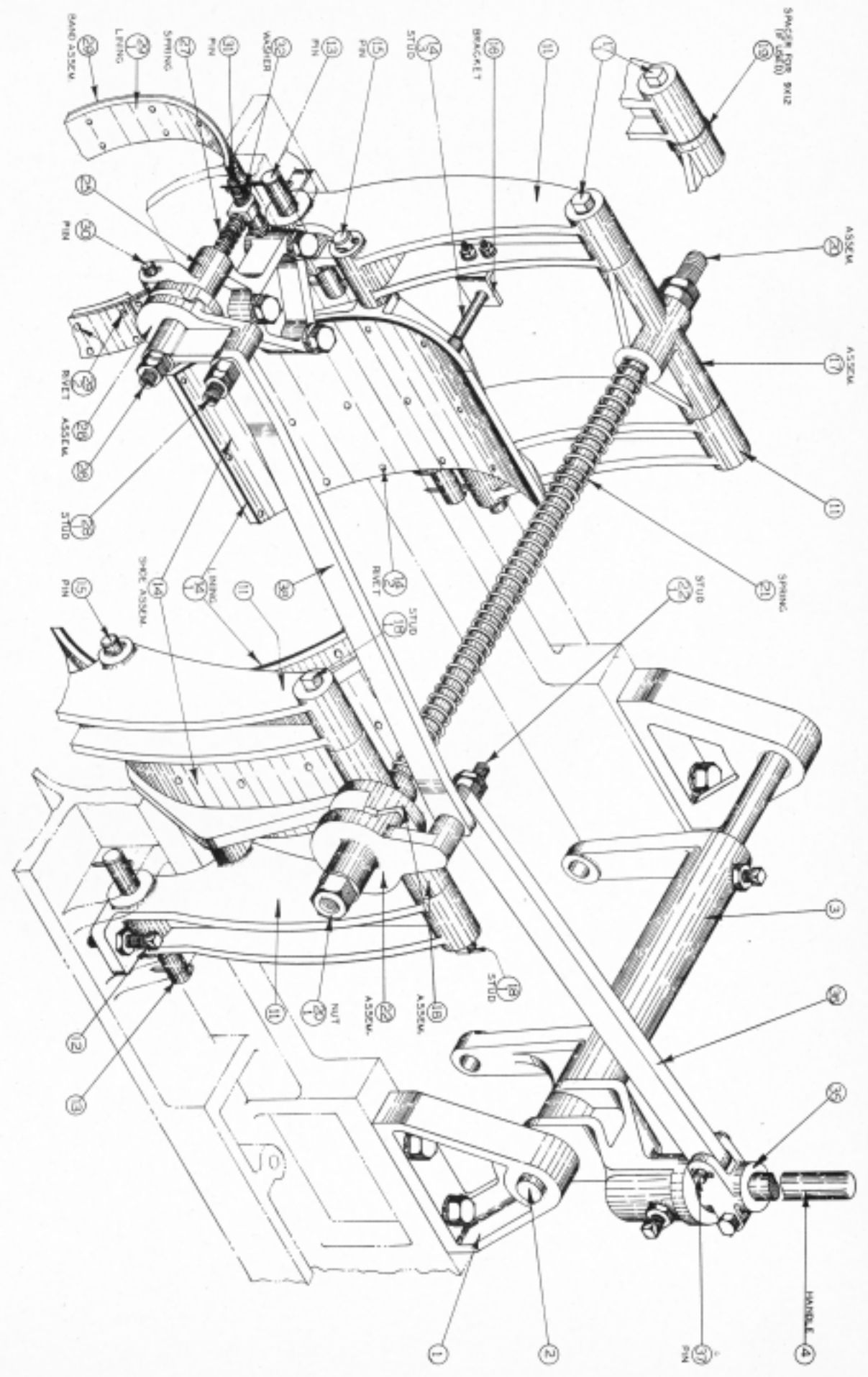

#1 Retyped from 12-4-36 (No change)

CHANGES

CHANGES

L-8436

ALWAYS GIVE PART NUMBER—PART NAME—ENGINE NUMBER
FOR STD. HARDWARE WITHOUT PART NUMBER GIVE DESCRIPTION AND SIZE
* INDICATES PART NOT SERVICED INDIVIDUALLY

PLATE NO. **K-2318**

LINE NO.	DRWG. NO.	REP. NO.	PART NO.	NO. REQ'D.	PART NAME	ASSEM. DRWG. NO.
						A-198
1		1	F-5162	2	STAND - Clutch Shifter	
2				4	CAPSCREW -- 3/4-10-NC x 1 3/4 Lg. -- (St.)	
3				4	LOCKWASHER -- 3/4 SAE Reg. -- (St.)	
4		2	C-7862	1	SHAFT - Clutch Shifter	
5		3	W-870	1	SHIFTER - Clutch	
6		4	F-5186	1	HANDLE - Clutch Shifter	
7				2	SETSCREW--1/2-13-NC x 1 1/4 Lg.--Sq. Head-Cup Point -- (St.)	
8				2	HALF NUT -- 1/2-13-NC-Hex. -- (St.)	
9						
10						
11						
12						
13						
14						
15						
16						
17						
18						
19						
20						
21						
22						
23						
24						
25						
26						
27						
28						
29						
30						
31						
32						
33						
34						
35						
36						
37						
38						
39						
40						
41						
42						
43						
44						
45						
46						
47						
48						
49						
50						

NAME **REVERSE GEAR CONTROL GROUP - - - - (19")**
ORIGINALLY ISSUED FOR **3-4 CYL. 7 1/2 x 10 1/2 MAR.**

PARTS LIST

ATLAS IMPERIAL DIESEL ENGINE CO.
GAKLAND, CALIF. MATTOON, ILL.

L-8436

EXTRA
COPIES TO:

TYPED BY DLB DATE 4-17-45

CHKD. *MED* DATE 5-2-45ISSUED BY *SM* APRVD.

#1 Retyped from 12-3-36 (no changes)

CHANGES

CHANGES

L-8468

ALWAYS GIVE PART NUMBER—PART NAME—ENGINE NUMBER
FOR STD. HARDWARE WITHOUT PART NUMBER GIVE DESCRIPTION AND SIZE
* INDICATES PART NOT SERVICED INDIVIDUALLYPLATE
NO.

LINE NO.	DRWG. NO.	REF. NO.	PART NO.	NO. REQ'D.	PART NAME	ASSEM. DRWG. NO.
1			W-888	1	BRACKET - Lube Oil Filter	
2			C-7915	1	GASKET - Bracket	
3				4	CAPSCREW -- 3/8-16-NC x 1 1/4 Lg. - - (St.)	
4				4	LOCKWASHER -- 3/8 SAE Reg. - - (St.)	
5						
6			PG 42	1	FILTER - Lube Oil	
7				2	CAPSCREW -- 1/2-13-NC x 1 1/4 Lg. - - (St.)	
8				2	LOCKWASHER -- 1/2 SAE Reg. - - (St.)	
9						
10						
11						
12						
13						
14						
15						
16						
17						
18						
19						
20						
21						
22						
23						
24						
25						
26						
27						
28						
29						
30						
31						
32						
33						
34						
35						
36						
37						
38						
39						
40						
41						
42						
43						
44						
45						
46						
47						
48						
49						
50						

SEE OFF HAND SEE

FOR OFF. NOT. SEE

NAME LUBE OIL FILTER GROUP

ORIGINALLY ISSUED FOR 4 CYL. 7 1/2 x 10 1/2 MARINE

FOR TOTAL REQUIREMENTS PER ENGINE MULTIPLY NO. REQ'D GIVEN ABOVE BY NO. REQ'D FOR GROUP GIVEN ON INDEX SHEET

PARTS LIST

ATLAS IMPERIAL DIESEL ENGINE CO.
OAKLAND, CALIF. MATTOON, ILL.

L-8468

#7 Revised & Retyped from 12-11-36
 #8 5-19-43 Added Union Fitt. Part Nos.

CHANGES

CHANGES

L-8480

ALWAYS GIVE PART NUMBER—PART NAME—ENGINE NUMBER
 FOR STD. HARDWARE WITHOUT PART NUMBER GIVE DESCRIPTION AND SIZE
 * INDICATES PART NOT SERVICED INDIVIDUALLY

PLATE NO.

A-218

LINE NO.	DRWG. NO.	REF. NO.	PART NO.	NO. REQD.	PART NAME	ASSEM. DRWG. NO.
---- L.P. Fuel Pump to Day Tank ----						
1				1	CLOSE NIPPLE -- 1/4 Std. - (W.I.)	
2				1	COUPLING -- 1/4 Std. Pipe - - (M.I.)	
3				1	ELBOW - Tube	
4	C-9804		C-9804-P 3/8	1	TUBE -- 3/8 O.D. x .035 x 44 Lg. -(S.D. Cop.)	
5				1	ELBOW - Tube	
6	C-9804		C-9804-P 3/8	1	REDUCING BUSHING -- 3/8 x 1/4 Std. - (C.I.)	
7				1	CLAMP - Tube	
8			S-2810	1	MACHINE SCREW--1/4-20 x 1/2 Lg.-Rnd. Hd.-(St.)	
9				1		
10				1		
11				1		
---- Day Tank to H.P. Fuel Pump ----						
12				1	NIPPLE -- 3/8 x 2 1/2 Lg. - (W.I.)	
13				1	GLOBE VALVE	
14	C-9048		C-9048-P 3/8	1	ELBOW - Tube	
15	C-9804		C-9804-P 1/2	1	TUBE -- 1/2 O.D. x .049 x 9 Lg.-(H.D. Cop.)	
16				1	CONNECTOR - Tube	
17	C-9801		C-9801-P 1/2	1	UNION TEE	
18	2C165		2C165-P 3/8	1	NIPPLE -- 3/8 x 2 1/2 Lg. - (W.I.)	
19				1	UNION ELBOW	
20	2C160		2C160-P 3/8	1	CLOSE NIPPLE -- 3/8 Std. - (W.I.)	
21				2		
22						
23						
---- Fuel Press. Relief Valve to Day Tank By-Pass Line ----						
24				1	CONNECTOR - Tube	
25	C-9801		C-9801-P 3/8	1	TUBE -- 3/8 O.D. x .035 x 32 Lg.-(S.D. Cop.)	
26				1	CONNECTOR - Tube	
27	C-9801		C-9801-P 3/8	1	TEE -- 1/2 x 1/2 x 1/4 Std. Reduc. -(M.I.)	
28				1	NIPPLE -- 1/2 x 8 Lg. - (W.I.)	
29						
30						
31						
32						
---- H.P. Fuel Pump Housing Drain ----						
33	C-9804		C-9804-P 3/8	1	ELBOW - Tube	
34				1	TUBE -- 3/8 O.D. x .035 x 44 Lg.-(S.D. Cop.)	
35			S-2810	1	CLAMP - Tube	
36				1	MACHINE SCREW--1/4-20 x 1/2 Lg.-Rnd.Hd.-(St.)	
37						
38						
39						
40						
41						
42						
43						
44						
45						
46						
47						
48						
49						
50						

FOR OFF. HAND SEE

FOR OFF. ROT. SEE

FORM 240 REV. 2-42 16 TRANS. 16 BOND

NAME L.P. FUEL PIPING GROUP

ORIGINALLY ISSUED FOR 4 CYL. 7 1/2 x 10 1/2 MARINE

FOR TOTAL REQUIREMENTS PER ENGINE MULTIPLY NO. REQ'D GIVEN ABOVE BY NO. REQ'D FOR GROUP GIVEN ON INDEX SHEET

PARTS LIST

ATLAS IMPERIAL DIESEL ENGINE CO.
 OAKLAND, CALIF. MATTOON, ILL.

L-8480

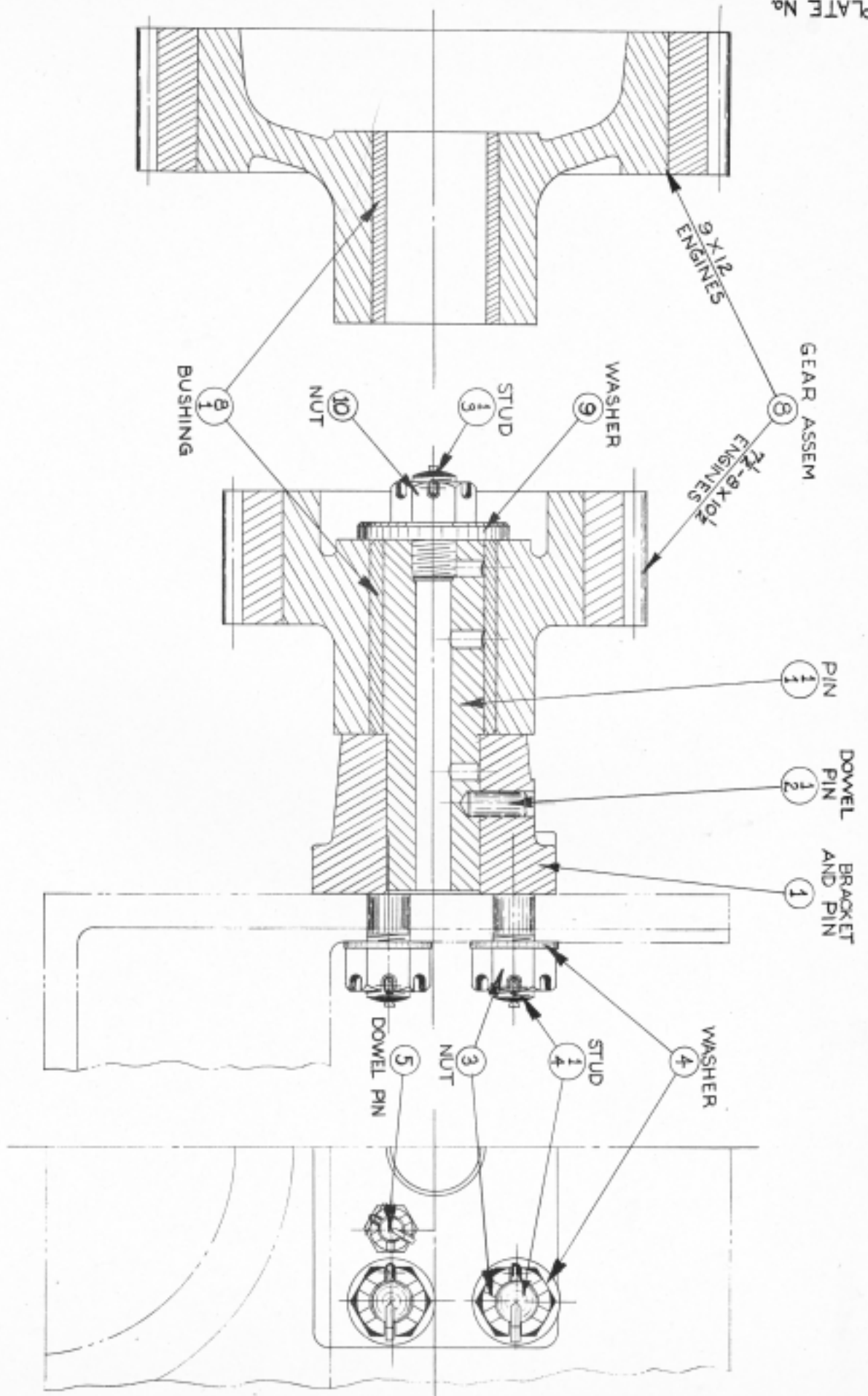

EXTRA
COPIES TO

TYPED BY DLB DATE

3-27-45

CHKD *MEG*

DATE 5-2-45

ISSUED BY *ML*

APRVD.

#3 Retyped from 12/9/36 (no changes)

CHANGES

CHANGES

L-8504

ALWAYS GIVE PART NUMBER—PART NAME—ENGINE NUMBER
FOR STD. HARDWARE WITHOUT PART NUMBER GIVE DESCRIPTION AND SIZE
* INDICATES PART NOT SERVICED INDIVIDUALLY

PLATE NO. W-2373

LINE NO.	DRWG. NO.	REF. NO.	PART NO.	NO. REQD.	PART NAME	ASSEM. DRWG. NO.
1	C-7891	1	X2068	1	BRACKET ASSEM. - Intermediate Gear (& Pin)	
2						
3		3		4	SLOTTED NUT -- 5/8-11-NC-Hex. -- (St.)	
4				4	COTTER PIN -- 1/8 x 1 1/4 Lg. -- (St.)	
5		4		4	PLAIN WASHER -- 5/8 SAE Std. -- (St.)	
6	C-7950	5	C-7950L1 3/4	2	PIN - Bracket to Bearing Cover Dowel	
7				2	CASTLE NUT -- 3/8-24-NF-Hex. -- (St.)	
8				2	COTTER PIN -- 3/32 x 3/4 Lg. -- (St.)	
9						
10	F-5237	8	X2078	1	GEAR ASSEM. - Intermediate	
11		9	C-7894	1	WASHER - Intermediate Gear Retainer	
12		10		1	SLOTTED NUT -- 5/8-11-NC-Hex. -- (St.)	
13				1	COTTER PIN -- 1/8 x 1 1/4 Lg. -- (St.)	
14						
15						
16						
17						
18						
19						
20						
21						
22						
23						
24						
25						
26						
27						
28						
29						
30						
31						
32						
33						
34						
35						
36						
37						
38						
39						
40						
41						
42						
43						
44						
45						
46						
47						
48						
49						
50						

FOR OFF. HAND SEE

NAME INTERMEDIATE GEAR GROUP

ORIGINALLY ISSUED FOR 9 x 12 MARINE - STATIONARY

FOR OFF. ROT. SEE

FOR TOTAL REQUIREMENTS PER ENGINE MULTIPLY NO. REQ'D GIVEN ABOVE BY NO. REQ'D FOR GROUP GIVEN ON INDEX SHEET

FORM 240 REV. 11-22-38

PARTS LIST

ATLAS IMPERIAL DIESEL ENGINE CO.

OAKLAND, CALIF.

MATTOON, ILL.

L-8504

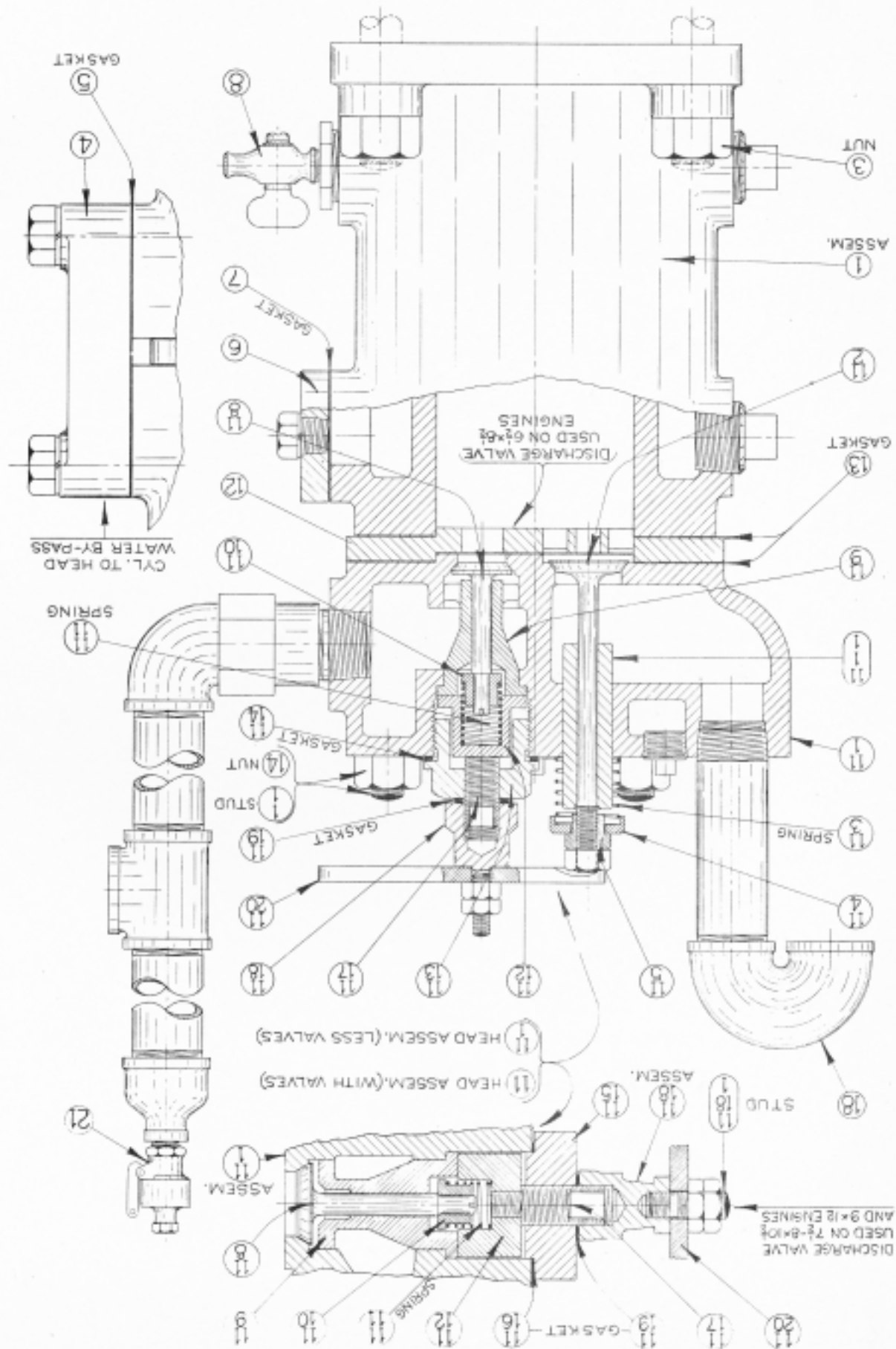

#6 Retyped from 3-11-43 (no change)

CHANGES

CHANGES

L-8508

PLATE
No. W-2106ALWAYS GIVE PART NUMBER—PART NAME—ENGINE NUMBER
FOR STD. HARDWARE WITHOUT PART NUMBER GIVE DESCRIPTION AND SIZE

LINE NO.	DRWG. NO.	REF. NO.	PART NO.	NO. REQ'D	PART NAME	ASSEM. DRWG. NO.
1	C-7388	1	X2089	1	CYLINDER ASSEM. - Air Compressor	
2						
3		3		4	NUT -- 5/8-11-NC-Hex. - - (St.)	
4	S-1710	4	34-X	1	PIPE - Cyl. to Head Water By-Pass	
5	S-618	5	610A-X	1	GASKET - Pipe to Cyl. & Head	
6				2	CAPSCREW -- 1/2-13-NC x 2 Lg. - - (St.)	
7				2	LOCKWASHER -- 1/2 SAE Reg. - - (St.)	
8		6	C-517	1	FLANGE - Water Inlet	
9		7	S-2332	1	GASKET - Flange to Cylinder	
10				2	CAPSCREW -- 3/8-16-NC x 1 Lg. - - (St.)	
11				2	LOCKWASHER -- 3/8 SAE Reg. - - (St.)	
12	C-9045	8	C-9045-P 1/4	1	COCK - Drain	
13						
14						
15	F-3604	11	G901-C31	1	HEAD ASSEM. - Air Compressor Cylinder	
16	F-3603	12	906-C3	1	GRID - Air Compressor	
17	S-1195	13	901A-C3	2	GASKET - Grid to Head & Cylinder	
18		14		4	NUT -- 5/8-11-NC-Hex. - - (St.)	
19						
20						
21						
22					---- Air Suction ----	
23				1	NIPPLE -- 1 x 4 Lg. - (W.I.)	
24		18		1	RETURN BEND -- 1 Std. - (M.I.)	
25						
26					---- Discharge Piping ----	
27				1	CLOSE NIPPLE -- 1 Std. - (W.I.)	
28				1	UNION ELBOW -- 1 Std. (Crane #590 or Eq.) - (M.I.)	
29				1	NIPPLE -- 1 x 10 Lg. - (W.I.)	
30				1	TEE -- 1 Std. - (M.I.)	
31				1	NIPPLE -- 1 x 4 Lg. - (W.I.)	
32				1	REDUCER (Bell) -- 1 x 1/2 Std. - (C.I.)	
33	C9974	21C-9974-P 1/2		1	VALVE - Pop Safety	
34						
35						
36						
37						
38						
39						
40						
41						
42						
43						
44						
45						
46						
47						
48						
49						
50						

FOR OFF. HAND SEE

NAME 4" AIR COMPRESSOR GROUP

ORIGINALLY
ISSUED FOR 3-4 CYL. 7 1/2-8x10 1/2 MARINE

FOR OFF. BOT. SEE

FOR TOTAL REQUIREMENTS PER ENGINE MULTIPLY NO. REQ'D GIVEN ABOVE BY NO. REQ'D FOR GROUP GIVEN ON INDEX SHEET

FORM 240 REV. 1/46 2M TRKND.
PRINTED IN U.S.A.

PARTS LIST

ATLAS IMPERIAL DIESEL ENGINE CO.
OAKLAND, CALIF. MATTOON, ILL.

L-8508

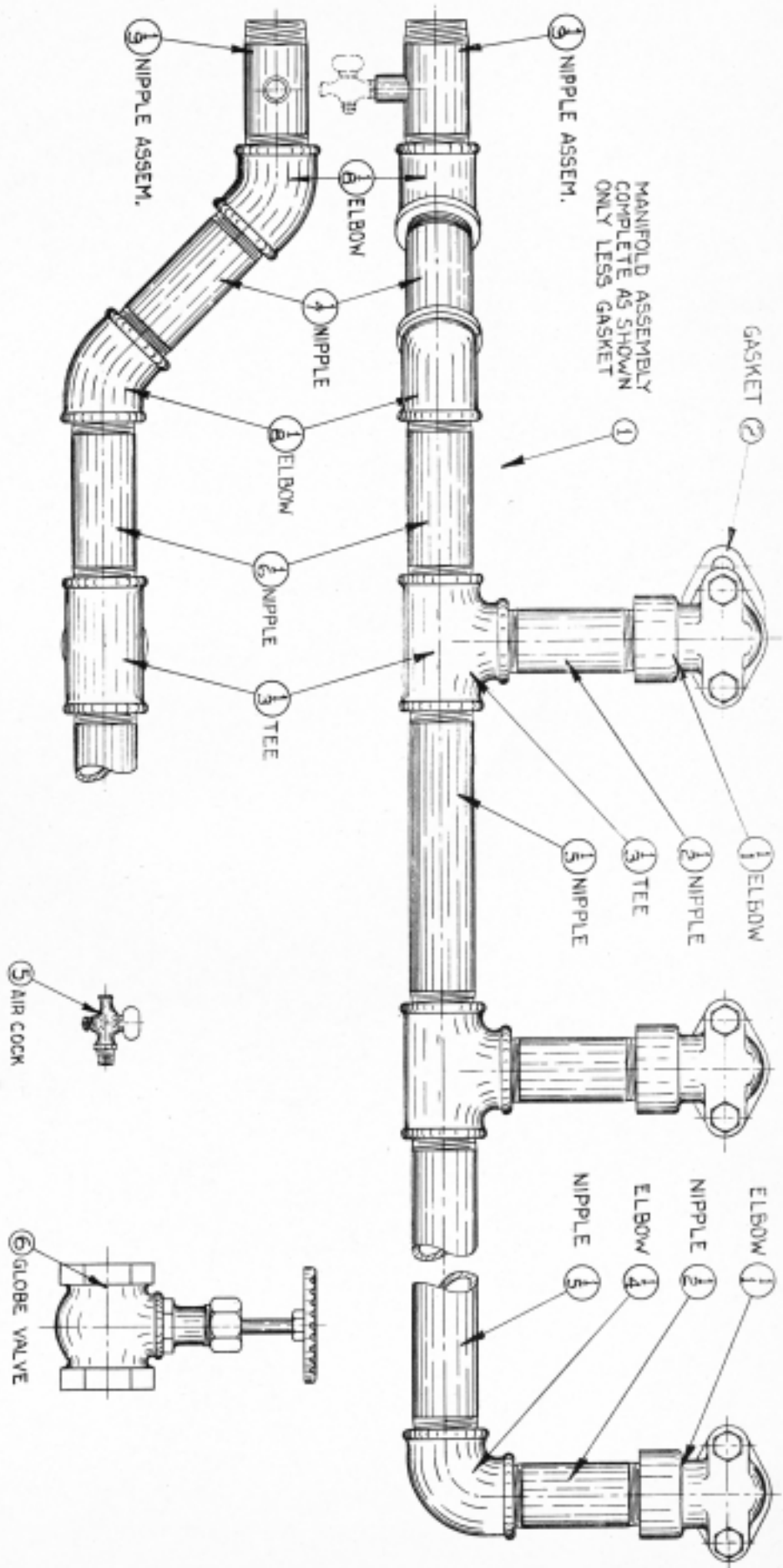

MANIFOLD ASSEMBLY
COMPLETE AS SHOWN
ONLY LESS GASKET

GASKET

3 NIPPLE ASSEM.

4 ELBOW

5 NIPPLE

6 AIR COCK

7 TEE

8 NIPPLE

9 ELBOW

10 NIPPLE

11 TEE

12 NIPPLE

13 ELBOW

14 NIPPLE

15 GLOBE VALVE

16 ELBOW

17 NIPPLE

EXTRA COPIES TO

TYPED BY DLB DATE 3-26-45

CHKD. DATE 5-2-45

ISSUED BY [Signature] APPVD.

#2 Retyped from 5/3/37 (no changes)

CHANGES

CHANGES

L-8823

PLATE NO. W-2438

ALWAYS GIVE PART NUMBER—PART NAME—ENGINE NUMBER FOR STD. HARDWARE WITHOUT PART NUMBER GIVE DESCRIPTION AND SIZE * INDICATES PART NOT SERVICED INDIVIDUALLY

LINE NO.	DRWG. NO.	REF. NO.	PART NO.	NO. REQD.	PART NAME	ASSEM. DRWG. NO.
1	F-5449	1	X2245	1	MANIFOLD ASSEM. - Air Starting	
2	S-1900	2	577A-C4	4	GASKET - Manifold to Cylinder Head	
3				8	CAPSCREW -- 1/2-13-NC x 2 1/2 Lg. -- (St.)	
4						
5	C-9045	5	C-9045-P 1/4	1	COCK - Air Bleeder	
6	C-9046	6	C-9046-P1 1/4	1	GLOBE VALVE	
7						
8						
9						
10						
11						
12						
13						
14						
15						
16						
17						
18						
19						
20						
21						
22						
23						
24						
25						
26						
27						
28						
29						
30						
31						
32						
33						
34						
35						
36						
37						
38						
39						
40						
41						
42						
43						
44						
45						
46						
47						
48						
49						
50						

FOR OFF. HAND SEC

FOR OFF. COPY SEC

FORM 240 REV. 8-44 14 TRANS.

NAME AIR STARTING MANIFOLD GROUP

ORIGINALLY ISSUED FOR 4 CYL. 9 x 12 MAR.- STAT.

FOR TOTAL REQUIREMENTS PER ENGINE MULTIPLY NO. REQ'D GIVEN ABOVE BY NO. REQ'D FOR GROUP GIVEN ON INDEX SHEET

PARTS LIST

ATLAS IMPERIAL DIESEL ENGINE CO. OAKLAND, CALIF. MATTOON, ILL.

L-8823

#2 Retyped from 7-15-37 (No change)

CHANGES

CHANGES

L-8867

ALWAYS GIVE PART NUMBER—PART NAME—ENGINE NUMBER
FOR STD. HARDWARE WITHOUT PART NUMBER GIVE DESCRIPTION AND SIZE
* INDICATES PART NOT SERVICED INDIVIDUALLY

PLATE NO. **K-2317**

LINE NO.	DRWG. NO.	REP. NO.	PART NO.	NO. REQ'D.	PART NAME	ASSEM. DRWG. NO.
1	C-7840	1	G331-C3	1	COLLAR ASSEM. - Cone Shifter	A-217
2		2	C-7856	2	PIN - Cone Shifter Collar	
3	F-5178	3	X2037	1	CONE ASSEM. - Clutch Shifter	
4	C-8356	4	314-C4	8	LINK - Cone to Crowder	
5	S-2040	5	313A-C3	4	PIN - Link to Cone	
6				8	COTTER PIN -- 5/32 x 1 Lg. -- (St.)	
7	C-8282	6	313-C6	4	CROWDER - Clutch Plate	
8	S-2041	7	314A-C3	4	PIN - Link to Crowder	
9				16	COTTER PIN -- 5/32 x 1 Lg. -- (St.)	
10	S-2042	8	315-C3	4	SPRING - Crowder	
11		9	G312-C3	1	COLLAR ASSEM. - Crowder Adjusting	
12		10	C-7861	2	PIN - Crowder to Adjusting Collar	
13				4	COTTER PIN -- 5/32 x 1 1/4 Lg. -- (St.)	
14		11	W-1106	1	PLATE - Clutch Hub (Driver)	
15		12	C-9546	1	KEY - Hub Plate & Drive Gear to Crankshaft	
16		13	C-9547	1	FELT - Hub Plate to Crankshaft Key	
17		14	W-1107	2	PLATE - Clutch Driven (Floating)	
18	W-1108	15	320-C4	1	PLATE - Clutch Drive (Floating)	
19		16	W-1109	1	PLATE - Clutch Pressure	
20		17	C-7878	4	SPRING - Clutch Plate	
21		18	W-1105	1	COVER - Clutch Plate	
22	C-8521	19	C-8521L5 1/4	10	CAPSCREW - Cover to Reverse Gear Drum	
23				2	PIPE PLUG -- 3/8 Std.--Countersunk Head--(C.I.)	
24						
25						
26						
27						
28						
29						
30						
31						
32						
33						
34						
35						
36						
37						
38						
39						
40						
41						
42						
43						
44						
45						
46						
47						
48						
49						
50						

NAME **REVERSE GEAR CLUTCH GROUP - - - - (21")**

ORIGINALLY ISSUED FOR **4 CYL. 9 x 12 MARINE**

FOR TOTAL REQUIREMENTS PER ENGINE MULTIPLY NO. REQ'D GIVEN ABOVE BY NO. REQ'D FOR GROUP GIVEN ON INDEX SHEET

PARTS LIST

ATLAS IMPERIAL DIESEL ENGINE CO.
OAKLAND, CALIF. MATTOON, ILL.

L-8867

FOR OFF. HAND SEE

FOR OFF. ROT. SEE

FORM 240 REV. (2-4) IN TRANS.

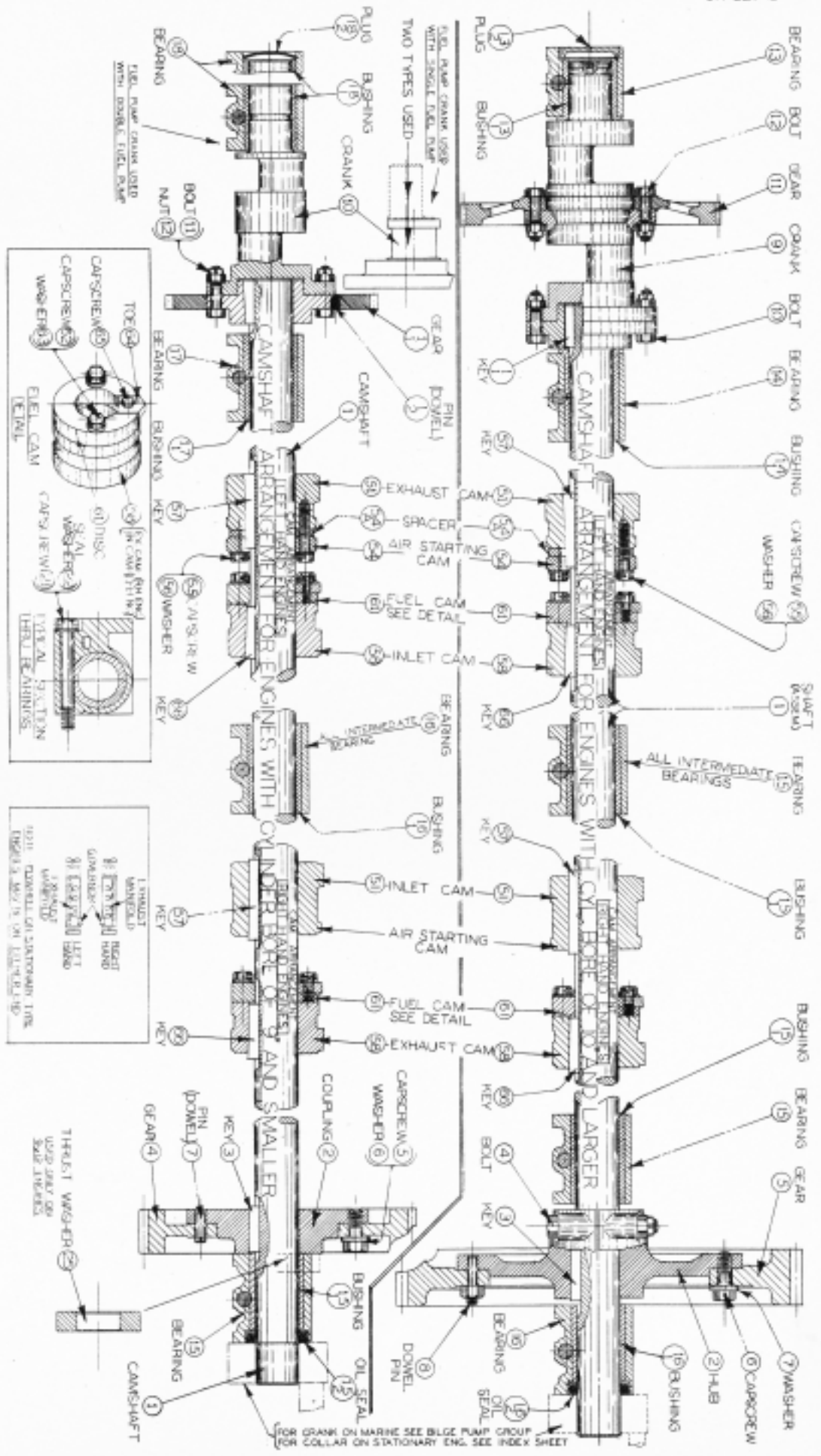

#2 Retyped from 3-26-45 (No changes)

CHANGES

L-8880

ALWAYS GIVE PART NUMBER—PART NAME—ENGINE NUMBER
FOR STD. HARDWARE WITHOUT PART NUMBER GIVE DESCRIPTION AND SIZE
* INDICATES PART NOT SERVICED INDIVIDUALLYPLATE
NO. K-2356

LINE NO.	DRWG. NO.	REF. NO.	PART NO.	NO. REQD.	PART NAME	ASSEM. DRWG. NO.
1	F-5463	1	X2256	1	CAMSHAFT ASSEMBLY	W-1124
2		2	F-3365	1	HUB - Camshaft Gear	
3	S-3234	3	5357	1	KEY - Hub to Camshaft	
4	F-3367	4	X248	1	GEAR ASSEMBLY - Camshaft Drive	
5	C-2510	5	C-2510L1 1/2	4	CAPSCREW - Gear to Hub	
6		6	S-2474	4	WASHER - Gear to Hub Capscrew	
7				1	WIRE -- #16 Ga. x 28 Lg. - - (St.)	
8		7	S-3350	1	PIN - Gear to Hub Dowel	
9						
10		10	W-883	1	CRANK - Fuel Pump	
11	C-2608	11	C-2608L2	4	BOLT - Crank to Coupling	
12				4	CASTLE NUT -- 1/2-20-NF-Hex. - - (St.)	
13				4	COTTER PIN -- 3/32 x 1 Lg. - - (St.)	
14						
15	C-7919	15	X2074	1	BEARING ASSEMBLY - Camshaft End (Gov. End)	
16	C-1342	16	G680-C	3	BEARING ASSEMBLY - Camshaft Center	
17	C-1343	17	G683-C4	1	BEARING ASSEMBLY - Camshaft End (Pump End)	
18	C-7940	18	X2076	1	BEARING ASSEMBLY - Fuel Pump Crank End	
19		21	C-4921	6	WASHER - Bearing to Centerframe Capscrew	
20		22		6	CAPSCREW -- 5/8-11-NC x 4 1/2 Lg. - (St.)	
21		25	C-1754	1	WASHER - Camshaft Thrust	
22						
23						
24						
25						
26						
27						
28						
29						
30						
31						
32						
33						
34						
35						
36						
37						
38						
39						
40						
41						
42						
43						
44						
45						
46						
47						
48						
49						
50						

FOR OFF. HAND SEE

L-9137

FOR OFF. ROT. SEE

NAME CAMSHAFT & FUEL PUMP CRANKGROUP

ORIGINALLY
ISSUED FOR 4 CYL. 9x12 MAR.-STAT.

FOR TOTAL REQUIREMENTS PER ENGINE MULTIPLY NO. REQ'D GIVEN ABOVE BY NO. REQ'D FOR GROUP GIVEN ON INDEX SHEET

PARTS LIST

ATLAS IMPERIAL DIESEL ENGINE CO.
OAKLAND, CALIF. MATTOON, ILL.

L-8880

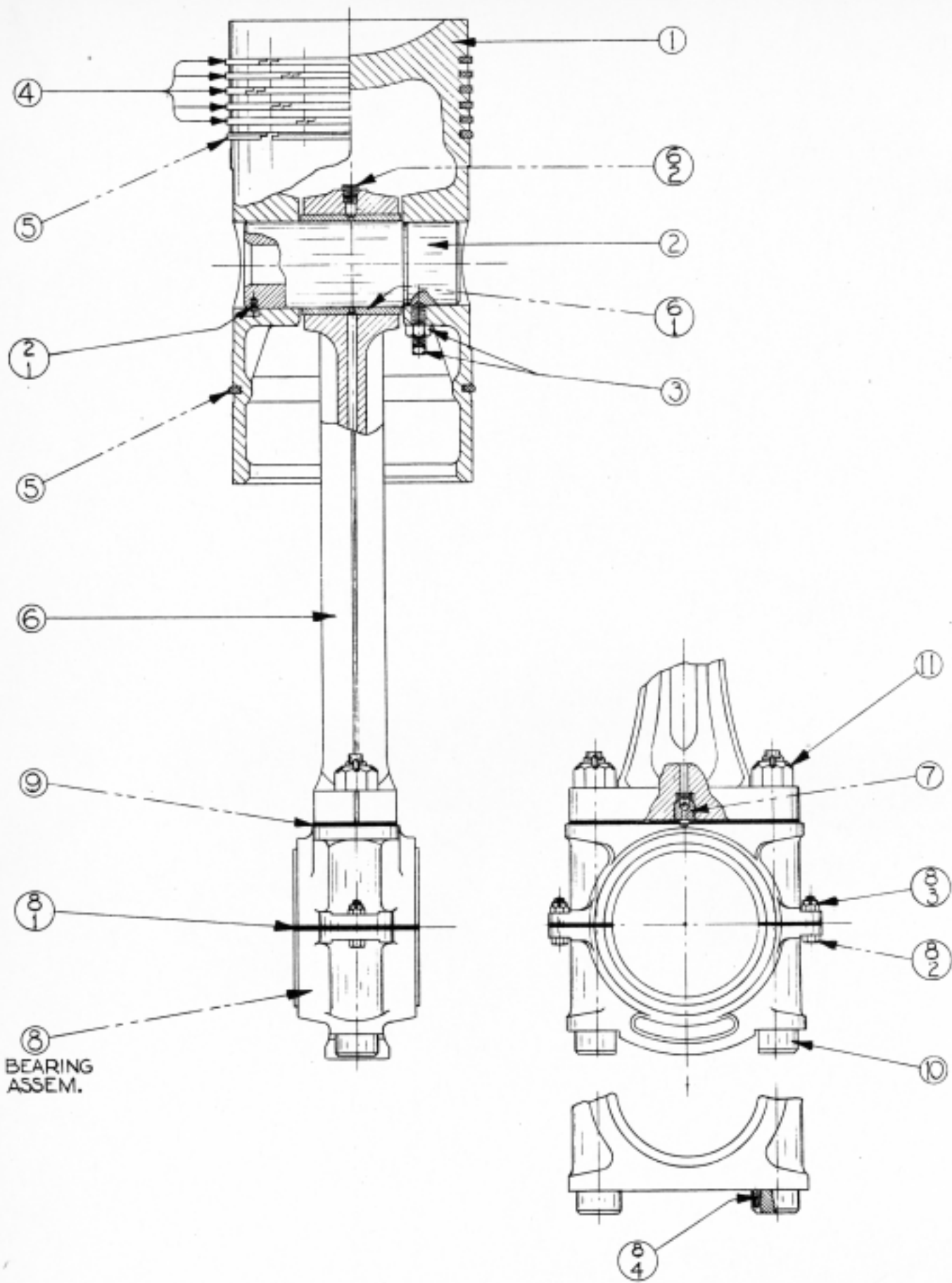

PLATE
 No. W-1751

DO NOT ORDER PARTS BY REF. NUMBERS

#2 Retyped from 7-16-37 (No changes)

CHANGES

CHANGES

L-8884

ALWAYS GIVE PART NUMBER—PART NAME—ENGINE NUMBER
FOR STD. HARDWARE WITHOUT PART NUMBER GIVE DESCRIPTION AND SIZE
* INDICATES PART NOT SERVICED INDIVIDUALLYPLATE
NO. W-1751

LINE NO.	DRWG. NO.	REF. NO.	PART NO.	NO. REQD.	PART NAME	ASSEM. DRWG. NO. W-1156
1	K-1347	1	620-F2	1	PISTON	
2	C-8478	2	G621-F	1	PIN ASSEM. - Piston	
3		3		1	SETScrew--5/8-11-NC x 1 3/4 Lg. Sq. Hd. Cup Pt. (St.)	
4		3		1	NUT -- 5/8-11-NC-Hex. - - (St.)	
5						
6	C-2155	4	C-2155L9	4	RING - Piston - (Compression)	
7	C-2355	5	C-2355L9	2	RING - Piston - (Oil Control)	
8						
9		6	GA630-FB4	1	ROD ASSEM. - Connecting	
10	C-5307	7	G632-E	1	VALVE ASSEM. - Oil Check	
11	W-931	8	GA636-E31	1	BEARING ASSEM. - Connecting Rod	
12	C-8497	9	634-E31-A	1	SHIM - Bearing to Rod (1/16)	
13	C-8497	9	634-E31-B	1	SHIM - Bearing to Rod (1/32)	
14	C-8497	9	634-E31-C	2	SHIM - Bearing to Rod (1/64)	
15		10	S-2722	2	BOLT - Connecting Rod	
16		11	S-2715	2	NUT - Connecting Rod Bolt	
17				2	COTTER PIN -- 3/16 x 2 Lg. - - (St.)	
18						
19						
20						
21						
22						
23						
24						
25						
26						
27						
28						
29						
30						
31						
32						
33						
34						
35						
36						
37						
38						
39						
40						
41						
42						
43						
44						
45						
46						
47						
48						
49						
50						

---- PARTS CATALOG NOTE ----

The Number of Compression Rings shown on Plate W-1751
may vary according to Engine Size.

FOR OFF HAND SEE

NAME PISTON & CONNECTING ROD GROUP

ORIGINALLY
ISSUED FOR 9 x 12 MARINE - STAT

FOR TOTAL REQUIREMENTS PER ENGINE MULTIPLY NO. REQ'D GIVEN ABOVE BY NO. REQ'D FOR GROUP GIVEN ON INDEX SHEET

PARTS LIST

ATLAS IMPERIAL DIESEL ENGINE CO.
OAKLAND, CALIF. MATTOON, ILL.

L-8884

EXTRA COPIES TO:

TYPED BY DLB

DATE 3-27-45

CHKD

JWB

DATE 5-2-45

ISSUED BY

JWB

APPROV

#1 Retyped from 7/16/37 (no changes)

CHANGES

CHANGES

ALWAYS GIVE PART NUMBER—PART NAME—ENGINE NUMBER
FOR STD. HARDWARE WITHOUT PART NUMBER GIVE DESCRIPTION AND SIZE
* INDICATES PART NOT SERVICED INDIVIDUALLY

L-8889

PLATE NO. W-2107

LINE NO.	DRWG. NO.	REP. NO.	PART NO.	NO. REQD.	PART NAME	ASSEM. DRWG. NO.
1	F-3084	1	925-C4	1	PISTON - Air Compressor	
2	S-763	2	927-C3	1	PIN - Piston	
3		3		1	SETScrew--5/16-18-NC x 1 Lg. Sq. Hd. Cup Point (St.)	
4				1	NUT -- 5/16-18-NC-Hex. -- (St.)	
5	C-2153	4	C-2153L4	2	RING - Piston (Compression)	
6	C-2453	5	C-2453L4	1	RING - Piston (Oil Control)	
7						
8		8	G929-C3	1	ROD ASSEM. - Connecting	
9	F-5506	9	X2268	1	STRAP ASSEM. - Eccentric	
10	C-2412	10	C-2412L1 3/4	2	CAPSCREW - Rod to Strap	
11				1	WIRE -- #16 Ga. x 9 Lg. -- (St.)	
12						
13						
14						
15						
16						
17						
18						
19						
20						
21						
22						
23						
24						
25						
26						
27						
28						
29						
30						
31						
32						
33						
34						
35						
36						
37						
38						
39						
40						
41						
42						
43						
44						
45						
46						
47						
48						
49						
50						

FOR OFF. HAND SEE

NAME PISTON, CONNECTING ROD & ECCENTRIC STRAP GROUP (4" AIR COMP)

ORIGINALLY ISSUED FOR 3-4 CYL. 9 x 12 MARINE

FOR OFF. ROT. SEE

FOR TOTAL REQUIREMENTS PER ENGINE MULTIPLY NO. REQ'D GIVEN ABOVE BY NO. REQ'D FOR GROUP GIVEN ON INDEX SHEET

PARTS LIST

ATLAS IMPERIAL DIESEL ENGINE CO.
OAKLAND, CALIF. MATTOON, ILL.

FORM 240 REV. 5-24-44 TRANS.

L-8889

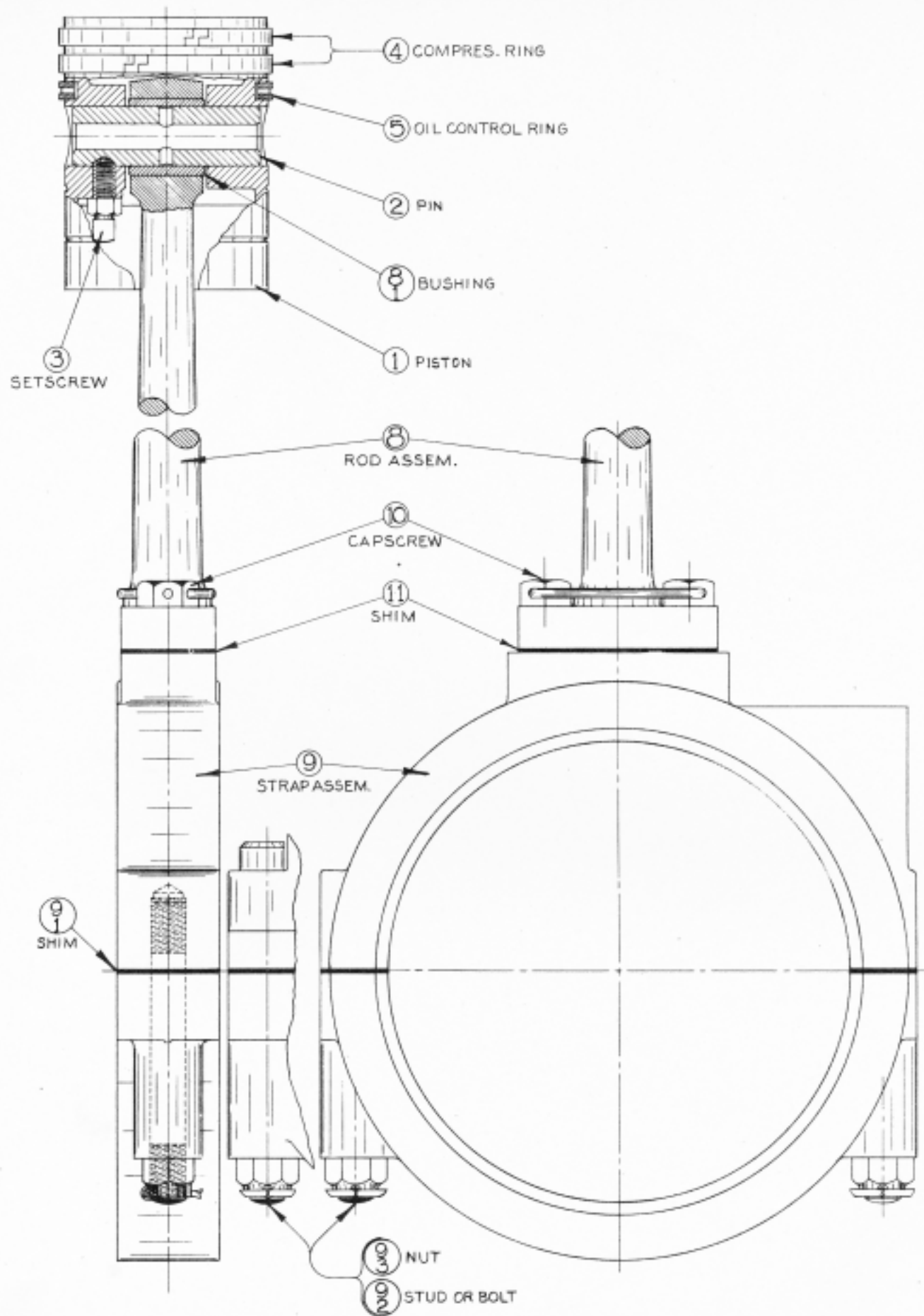

PLATE No.
W-2107

DO NOT ORDER PARTS BY REF. NUMBERS

EXTRA
COPIES TO

TYPED BY DLB DATE 3-26-45

CHKD M.E.D. DATE 5-16-45

ISSUED BY

APPROV.

#1 Retyped from 7/19/37 (no changes)

CHANGES

CHANGES

L-8904

PLATE NO. W-2440

ALWAYS GIVE PART NUMBER—PART NAME—ENGINE NUMBER
FOR STD. HARDWARE WITHOUT PART NUMBER GIVE DESCRIPTION AND SIZE
* INDICATES PART NOT SERVICED INDIVIDUALLY

LINE NO.	DRWG. NO.	REF. NO.	PART NO.	NO. REQ'D.	PART NAME	ASSEM. DRWG. NO.
1	C-6623	1	C-6623L61	1	SHAFT - Fuel Wedge	
2	S-3292	2	1134-E	4	BEARING - Wedge Shaft	
3	C-4363	3	X929	1	BEARING ASSEM. - Wedge Shaft	
4				5	NUT -- 1/2-13-NC-Hex. -- (St.)	
5				5	LOCKWASHER -- 1/2 SAE Reg. -- (St.)	
6		4	C-3385	1	BRACKET - Wedge Shaft End Brg.	
7				2	CAPSCREW -- 1/2-13-NC x 1 3/4 Lg. -- (St.)	
8				2	LOCKWASHER -- 1/2 SAE Reg. -- (St.)	
9	C-3465	5	1131-C4	4	FORK - Fuel Wedge	
10				4	CAPSCREW -- 3/8-16-NC x 1 Lg. -- (St.)	
11		6		4	TAPER PIN -- #3 x 1 1/2 Lg. -- (St.)	
12	F-897	7	1132-E	4	WEDGE - Fuel	
13	S-752	8	1132A-E	4	PIN - Fuel Wedge to Fork	
14				4	COTTER PIN -- 1/8 x 1 Lg. -- (St.)	
15		9	S-862	1	COLLAR - Wedge Shaft Retainer	
16		10		1	SETSCREW--1/4-20-NC x 3/8 Lg.--Sq.Hd.Cup Pt. (St.)	
17		11	S-1582	1	SPACER - Wedge Shaft	
18						
19	F-3378	12	1139-E4	1	GUARD - Wedge Shaft	
20	S-2004	14	1141-E	4	SPACER - Wedge Shaft Guard	
21		15		4	CAPSCREW -- 5/8-11-NC x 4 3/4 Lg. -- (St.)	
22				4	LOCKWASHER -- 5/8 SAE Reg. -- (St.)	
23						
24						
25						
26						
27						
28						
29						
30						
31		22	C-6496	1	LEVER - Wedge Shaft Control	
32				1	CAPSCREW -- 3/8-16-NC x 1 Lg. -- (St.)	
33		23		1	TAPER PIN -- #3 x 1 1/4 Lg. -- (St.)	
34		24	C-8040	1	ROD - Wedge Shaft Control	
35				2	NUT -- 3/8-24-NF-Hex. -- (St.)	
36		25	C-8408	1	JOINT - Ball and Socket	
37				1	NUT -- 3/8-24-NF-Hex. -- (St.)	
38				1	LOCKWASHER -- 3/8 SAE Reg. -- (St.)	
39						
40						
41						
42						
43						
44						
45						
46						
47						
48						
49						
50						

FOR OFF. HAND SEE

NAME FUEL WEDGE SHAFT GROUP

ORIGINALLY ISSUED FOR 4 CYL. 9 x 12 MARINE - STAT.

FOR OFF. ROT. SEE

FOR TOTAL REQUIREMENTS PER ENGINE MULTIPLY NO. REQ'D GIVEN ABOVE BY NO. REQ'D FOR GROUP GIVEN ON INDEX SHEET

PARTS LIST

ATLAS IMPERIAL DIESEL ENGINE CO.

FORM 240 REV. 8-24-38 TRANS.

L-8904

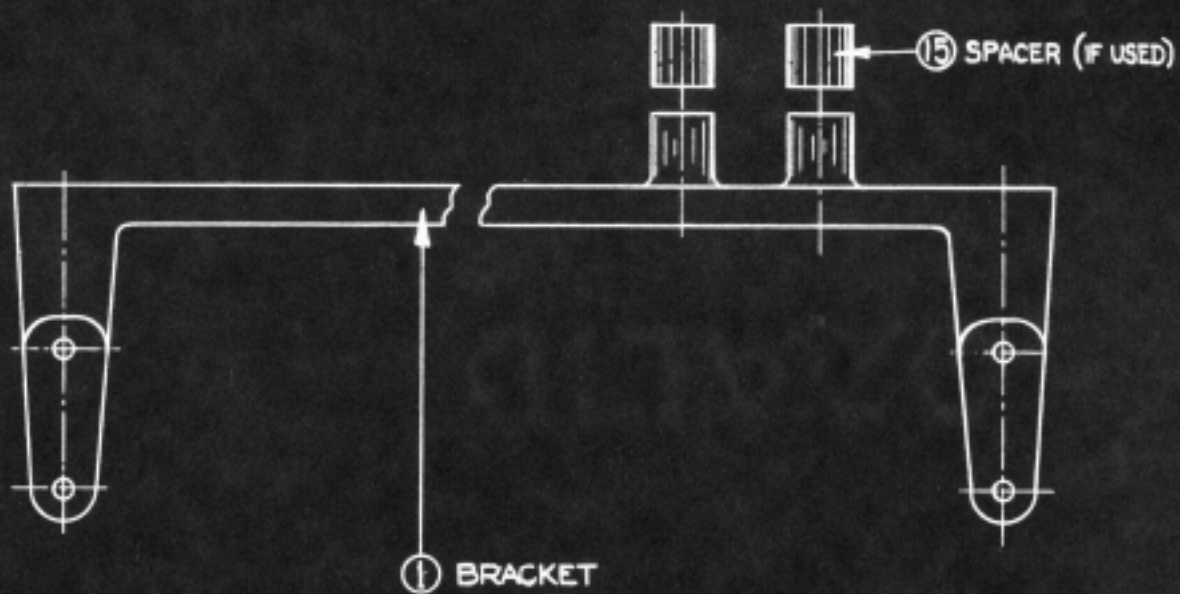
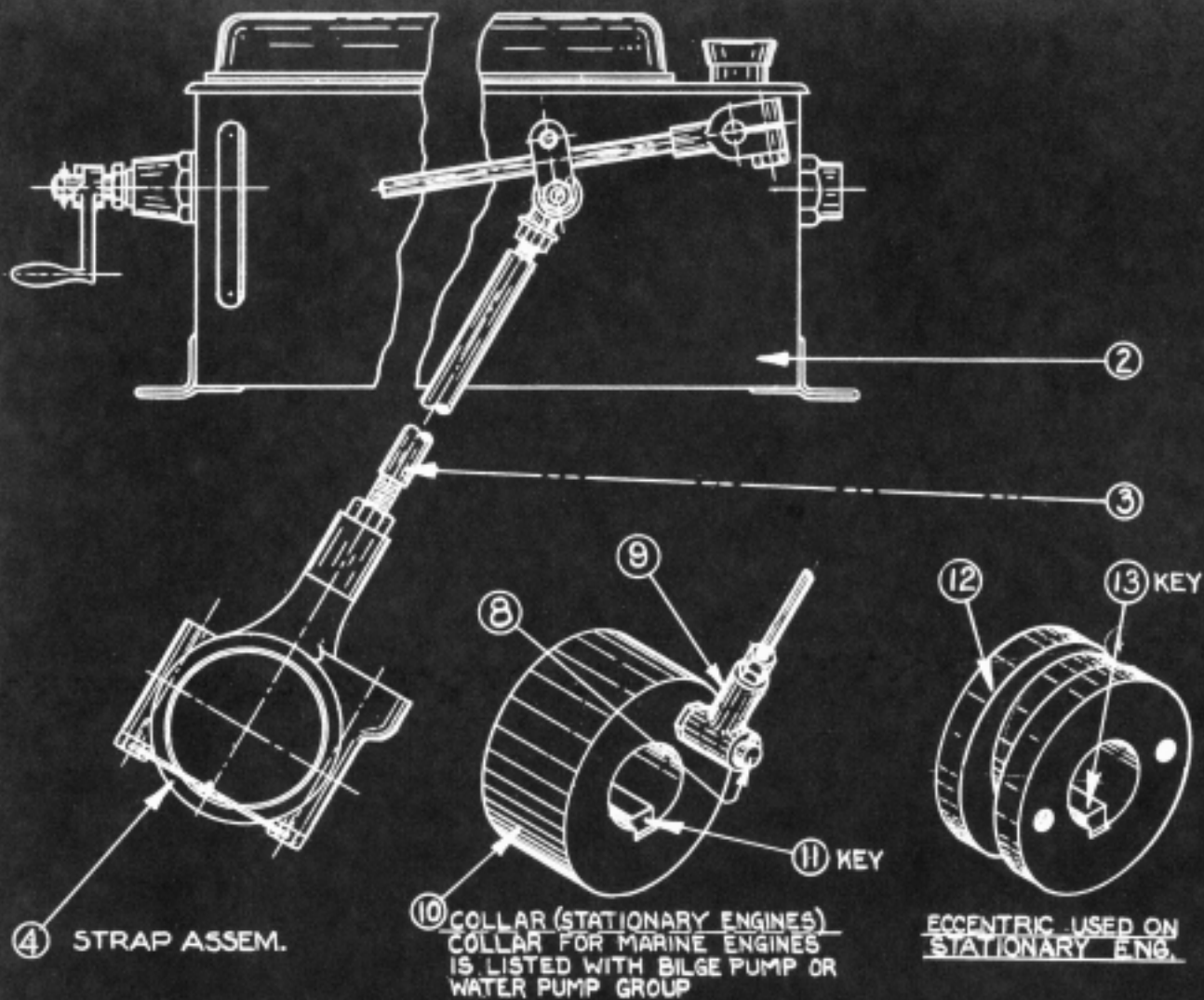

#3 Retyped from 5-15-39 (No changes)

CHANGES

L-8909

ALWAYS GIVE PART NUMBER—PART NAME—ENGINE NUMBER
FOR STD. HARDWARE WITHOUT PART NUMBER GIVE DESCRIPTION AND SIZE
* INDICATES PART NOT SERVICED INDIVIDUALLY

PLATE NO. W-1746

LINE NO.	DRWG. NO.	REF. NO.	PART NO.	NO. REQ'D.	PART NAME	ASSEM. DRWG. NO.
1		1	F-5249	1	BRACKET - Lubricator	
2				4	CAPSCREW -- 1/2-13-NC x 1 1/2 Lg. - (St.)	
3				4	LOCKWASHER -- 1/2 SAE Reg. - - (St.)	
4	F-7148	2	F-7148-P9	1	LUBRICATOR -- Madison-Kipp R.H. Side Drive -	
5					9 Feed	
6				4	CAPSCREW -- 3/8-16-NC x 1 1/4 Lg. - (St.)	
7				4	NUT -- 3/8-16-NC-Hex. - - (St.)	
8				4	PLAIN WASHER -- 3/8 SAE Std. - - (St.)	
9				4	LOCKWASHER -- 3/8 SAE Reg. - - (St.)	
10		3	C-8428	1	ROD - Lubricator Drive	
11				2	HALF NUT -- 3/8-16-NC-Hex. - - (St.)	
12		8	C-1223	1	PIN - Lubricator Drive	
13	C-500	9	253-X	1	EYE - Lubricator Drive Rod	
14				1	PLAIN WASHER -- 1/2 SAE Std. - (St.)	
15				1	COTTER PIN -- 1/8 x 1 Lg. - (St.)	
16						
17						
18						
19					--- Lubricator to Cylinder - Cam Side ---	
20				1	TUBE(Cyl. 1)-- $\frac{1}{2}$ O.D. x .030 x 20 Lg.--(S.D. Cop.)	
21				1	TUBE(Cyl. 2)-- $\frac{1}{2}$ O.D. x .030 x 37 Lg.--(S.D. Cop.)	
22				1	TUBE(Cyl. 3)-- $\frac{1}{2}$ O.D. x .030 x 54 Lg.--(S.D. Cop.)	
23				1	TUBE(Cyl. 4)-- $\frac{1}{2}$ O.D. x .030 x 71 Lg.--(S.D. Cop.)	
24	C-9832		C-9832-P 1/4	4	ELBOW - Tube Fitting	
25					--- Lubricator to Cylinder - Exhaust Side ---	
26				1	TUBE(Cyl. 1)-- $\frac{1}{2}$ O.D. x .030 x 30 Lg.--(S.D. Cop.)	
27				1	TUBE(Cyl. 2)-- $\frac{1}{2}$ O.D. x .030 x 44 Lg.--(S.D. Cop.)	
28				1	TUBE(Cyl. 3)-- $\frac{1}{2}$ O.D. x .030 x 58 Lg.--(S.D. Cop.)	
29				1	TUBE(Cyl. 4)-- $\frac{1}{2}$ O.D. x .030 x 72 Lg.--(S.D. Cop.)	
30	C-9832		C-9832-P 1/4	4	ELBOW - Tube Fitting	
31						
32					--- Lubricator to Thrust Bearing ---	
33				1	TUBE -- $\frac{1}{2}$ O.D. x .030 x 142 Lg.--(S.D. Copper)	
34	C-9830		C-9830-P 1/4	1	CONNECTOR - Tube Fitting	
35				1	TEE -- 1/4 x 1/4 x 1/8 Std. Reducing - (M.I.)	
36				1	PIPE PLUG -- 1/4 Std.-- (Brass)	
37				1	NIPPLE -- 1/4 x 4 Lg. - (Brass)	
38	2C3		2C3-P	2	CLAMP - Oil Tube to Thrust Brg. Water Pipe	
39				2	MACHINE SCREW--3/8-16-NC x $\frac{1}{2}$ Lg.--Rnd.Hd.--(St.)	
40				2	HALF NUT -- 3/8-16-NC-Hex. - - (St.)	
41	C-9831		C-9831-P 1/4	1	UNION - Tube Fitting	
42						
43			S-1492	4	CLAMP - Tube - (2 - 1/4 O.D. Tubes)	
44			S-1493	4	CLAMP - Tube - (3 - 1/4 O.D. Tubes)	
45			S-1494	4	CLAMP - Tube - (4 - 1/4 O.D. Tubes)	
46			S-1495	3	CLAMP - Tube - (5 - 1/4 O.D. Tubes)	
47				15	MACHINE SCREW-- $\frac{1}{2}$ -20 x 3/8 Lg.Rnd.Hd.--(St.)	
48				15	NUT -- 1/4-20-NC-Hex. - - (St.)	
49						
50						

FOR OFF. HAND SEE

L-8910

FOR OFF. NOT. SEE

NAME LUBRICATOR & PIPING GROUP

ORIGINALLY

ISSUED FOR

4CYL. 9 x 12 MARINE - R.H.

FOR TOTAL REQUIREMENTS PER ENGINE MULTIPLY NO. REQ'D GIVEN ABOVE BY NO. REQ'D FOR GROUP GIVEN ON INDEX SHEET

PARTS LIST

ATLAS IMPERIAL DIESEL ENGINE CO.

OAKLAND, CALIF.

MATTOON, ILL.

L-8909

-SPRAY VALVE ASSEMBLY-
-SPRAY VALVE LESS TIP

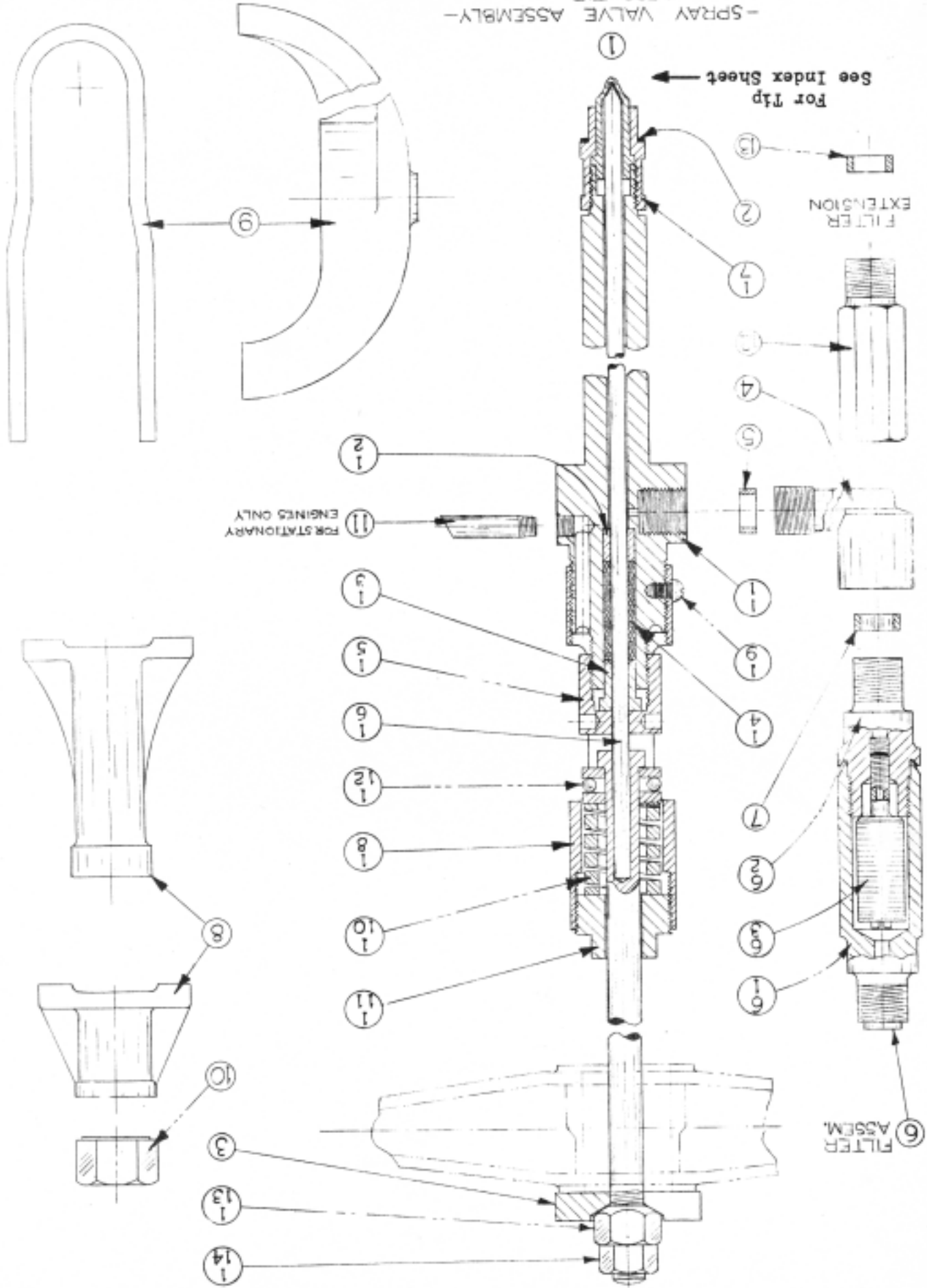

FILTER EXTENSION

FILTER ASSEM.

FOR STATIONARY ENGINES ONLY

See Index Sheet

NOTE - INSIDE DIA. MUST BE CONCENTRIC TO OUTSIDE DIA. WITHIN .005" AT FORMED END

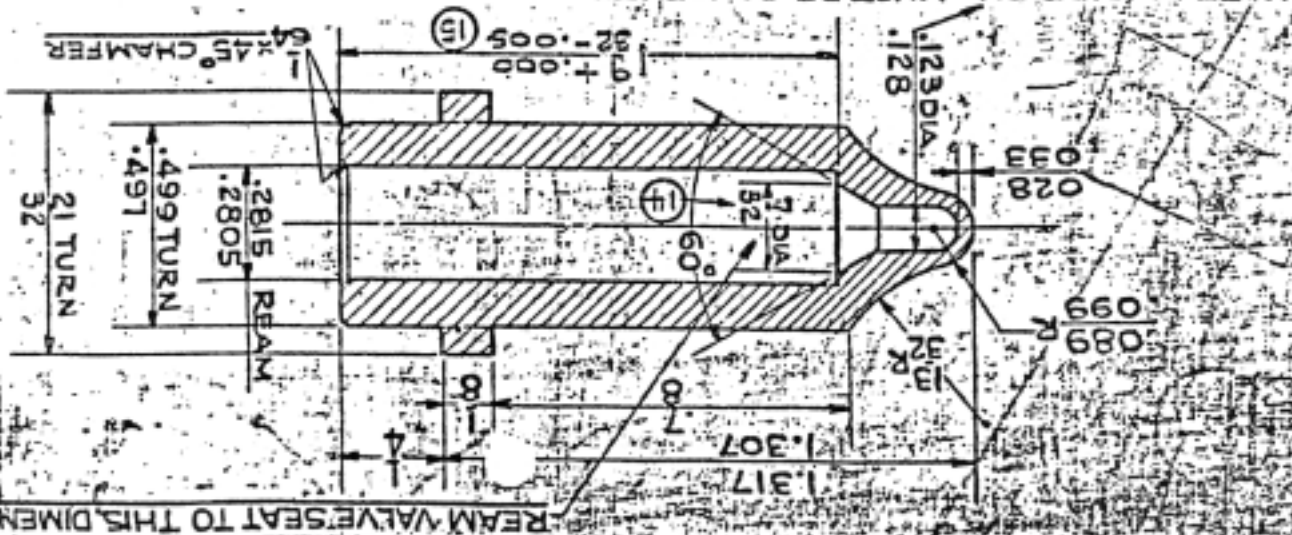

REAM VALVE SEAT TO THIS DIMENSION

SPRAY VALVE TIP-BLANK

PART No. 864.E

MAT'L S.A.E. 1112

SEE TABULATION FOR DRILLING

PART No	SIZE	L-SHEET	PART No	SIZE	L-SHEET
5829	7 30	.014	5829	7 30	.014
5830	7 30	.012	5830	7 30	.012
5831	5 30	.014	5831	5 30	.014
5832	5 30	.012	5832	5 30	.012
5833	5 30	.011	5833	5 30	.011
5834	5 30	.010	5834	5 30	.010
5835	5 30	.009	5835	5 30	.009
5836	5 30	.008	5836	5 30	.008
5837	5 30	.007	5837	5 30	.007
5838	4 30	.008	5838	4 30	.008
5839	4 30	.007	5839	4 30	.007
5840	7 20	.009	5840	7 20	.009
5841	6 20	.009	5841	6 20	.009
5842	5 20	.009	5842	5 20	.009
5843	5 20	.008	5843	5 20	.008
5844	5 20	.009	5844	5 20	.009
5845	5 20	.008	5845	5 20	.008
5846	5 15	.010	5846	5 15	.010
5847	5 15	.009	5847	5 15	.009
5848	5 15	.008	5848	5 15	.008
5849	4 15	.008	5849	4 15	.008
5863	5 12	.011	5863	5 12	.011
5864	5 12	.010	5864	5 12	.010
5865	5 12	.009	5865	5 12	.009
5866	5 12	.008	5866	5 12	.008
5867	4 12	.008	5867	4 12	.008
5900	5 12	.007	5900	5 12	.007
6002	5 30	.013	6002	5 30	.013

PART No	SIZE	L-SHEET	PART No	SIZE	L-SHEET
6134	7 30	.013	6134	7 30	.013
6168	6 30	.008	6168	6 30	.008
6169	6 30	.011	6169	6 30	.011
6172	8 30	.014	6172	8 30	.014
6178	7 25	.016	6178	7 25	.016
6184	7 25	.013	6184	7 25	.013
6186	6 15	.012	6186	6 15	.012
6200	6 15	.011	6200	6 15	.011
6201	5 25	.011	6201	5 25	.011
6202	7 20	.010	6202	7 20	.010
RA-8	8 15	.016	RA-8	8 15	.016
RA-11	6 25	.011	RA-11	6 25	.011
RA-30	6 20	.011	RA-30	6 20	.011
RA-41	6 20	.010	RA-41	6 20	.010
RA-117	6 30	.013	RA-117	6 30	.013
RA-190	8 25	.016	RA-190	8 25	.016
RA-232	6 25	.013	RA-232	6 25	.013

ACE TUGBOAT COMPANY

DAN GRINSTEAD

HEAVY-DUTY DIESELS, MARINE ELECTRICAL,
FUEL SYSTEMS, TOWING

6119 Latona N.E.
Seattle, Washington 98115
(206) 524-2750

CHG	AS	DATE	BY	CHG	AS	DATE	BY
22	RA-30 ADDED	3-9-51	MR	28	RA232 ADDED	3-10-51	MR
21	RA-11 ADDED	1-19-51	MR	27	RA-190 ADDED	11-25-51	MR
20	RA-8 ADDED	12-11-50	MR	26	WAS .010 DIA HOLE	9-4-51	MR
19	ADDED 6202	3-24-48	MR	25	WAS .011 DIA HOLE	9-4-51	MR
18	ADDED 6201	8-12-46	MR	24	RA117 ADDED	11-25-51	MR
17	ADDED 6200	1-23-46	MR	23	RA-41 ADDED	10-4-51	MR
16	ADDED 6186	1-3-41	MR				
15	ADDED 6178	12-16-40	MR				
14	ADDED 6172	11-16-40	MR				
13	ADDED 6169	11-16-40	MR				
12	REVISED (REDRAWN)	11-21-40	MR				
11	FROM PRODUCTION	11-11-39	MR				

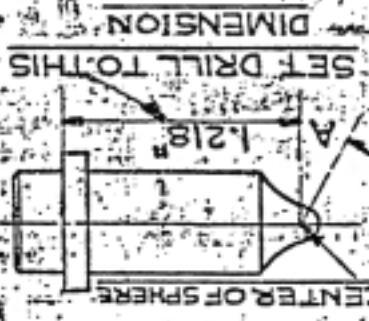

Retyped from 1/31/38 (no change)

CHANGES
#1

CHANGES

L-9483

ALWAYS GIVE PART NUMBER—PART NAME—ENGINE NUMBER
FOR STD. HARDWARE WITHOUT PART NUMBER GIVE DESCRIPTION AND SIZE
* INDICATES PART NOT SERVICED INDIVIDUALLY

PLATE NO. W-1596

LINE NO.	DRWG. NO.	REF. NO.	PART NO.	NO. REGD.	PART NAME	ASSEM. DRWG. NO.
1	W-182	1	X261	1	VALVE ASSEMBLY - Fuel Spray	
2	S-923	2	860-E	1	GASKET - Spray Valve to Cyl. Head	
3	C-179	3	877-E	1	COLLAR - Spray Valve to Rocker Retainer	
4		4	S-2231	1	CONNECTION - Spray Valve Fuel Filter	
5	S-928	5	861A-E	1	GASKET - Filter Connection to Spray Valve	
6	F-1981	6	X71	1	FILTER ASSEMBLY - Spray Valve Fuel	
7	S-928	7	861A-E	1	GASKET - Filter to Connection	
8	C-159	8	855-R	1	BRIDGE - Spray Valve Retainer	
9	S-2295	9	854-E	1	CLAMP - Spray Valve Bridge	
10	C-278	10	855A-FXC4	1	NUT - Spray Valve Bridge Clamp Retainer	
11						
12						
13						
14						
15						
16						
17						
18						
19						
20						
21						
22						
23						
24						
25						
26						
27						
28						
29						
30						
31						
32						
33						
34						
35						
36						
37						
38						
39						
40						
41						
42						
43						
44						
45						
46						
47						
48						
49						
50						

FOR OFF. HAND SEE

NAME FUEL SPRAY VALVE GROUP

ORIGINALLY ISSUED FOR 3-4 CYL. 7 1/2 x 10 1/2 MARINE

FOR OFF. ROT. SEE

FOR TOTAL REQUIREMENTS PER ENGINE MULTIPLY NO. REQ'D GIVEN ABOVE BY NO. REQ'D FOR GROUP GIVEN ON INDEX SHEET

FORM 240 REV. 3-42 14 TRANS.
14 BOND

PARTS LIST

ATLAS IMPERIAL DIESEL ENGINE CO.
OAKLAND, CALIF. MATTOON, ILL.

L-9483

#1 Retyped from 5-15-39 (no changes)

CHANGES

CHANGES

ALWAYS GIVE PART NUMBER—PART NAME—ENGINE NUMBER
FOR STD. HARDWARE WITHOUT PART NUMBER GIVE DESCRIPTION AND SIZE
* INDICATES PART NOT SERVICED INDIVIDUALLYL-9877
PLATE NO. K-2307

LINE NO.	DRWG. NO.	REP. NO.	PART NO.	NO. REQD.	PART NAME	ASSEM. DRWG. NO. K-1341
1		1	X2854	1	BASE ASSEMBLY	
2				1	PIPE PLUG -- 2 Std. -- (C.I.)	
3				2	PIPE PLUG -- 3/4 Std. -- (C.I.)	
4		2	C-8392	1	PLUG - Lube Oil Pipe Hole	
5	C-211	3	1247-E	1	GASKET - Plug to Base	
6	C-7958	4	X2081	1	SEAL ASSEM. - Crankshaft Oil - (Fwd. End)	
7		5	S-2257	1	GASKET - Oil Seal to Base	
8		6	C-1379	2	FELT - Oil Seal	
9	C-8524	7	X1470	1	SEAL ASSEM. - Crankshaft Oil - (Aft. End)	
10		8	S-2257	1	GASKET - Oil Seal to Base	
11		9	C-8525	2	FELT - Oil Seal	
12				12	CAPSCREW -- 3/8-16-NC x 7/8 Lg. - (St.)	
13				12	LOCKWASHER -- 3/8 SAE Reg. - - (St.)	
14	C-7871	10	X2059	1	STRAINER ASSEM. - Lube Oil - (Sump)	
15		11	C-8391	1	COVER - Base Oil Sump Hole	
16		12	C-7411	2	GASKET - Strainer & Cover to Base	
17				8	CAPSCREW -- 3/8-16-NC x 3/4 Lg. - (St.)	
18				8	LOCKWASHER -- 3/8 SAE Reg. - - (St.)	
19		16	C-8380	1	PLATE - Centrifugal Water Pump Support	
20				2	CAPSCREW -- 1/2-13-NC x 1 1/4 Lg. - (St.)	
21				2	LOCKWASHER -- 1/2 SAE Reg. - - (St.)	
22		17	C-8389	1	COVER - Pump Drive Chain Hole - (Operat. Side)	
23		18	C-8377	1	GASKET - Cover to Base	
24				4	CAPSCREW -- 1/2-13-NC x 1 1/4 Lg. - (St.)	
25				4	LOCKWASHER -- 1/2 SAE Reg. - - (St.)	
26		19	C-8466	3	NIPPLE - Lube Oil Connect. - (Thru Base)	
27		21	S-1974	3	WASHER - Lube Oil Nipple Seal	
28	C-3278	22	367-01	3	LOCKNUT - Lube Oil Nipple	
29		23	C-9558	2	PLUG - Centerframe & Cyl. Stud Hole	
30						
31						
32					-- Base to Manifold Oil Line -(Man. Inlet)--	
33	C-9805	28	C-9805-P 5/8	1	ELBOW - Tube Fitting - (Female)	
34		29		1	TUBE--5/8 O.D. x .049 x 16 Lg.--(H.D. Copper)	
35	C-9804	30	C-9804-P 5/8	1	ELBOW - Tube Fitting - (Male)	
36						
37					-- Lube Oil Cross-over Line in Base --	
38	C-9805	31	C-9805-P 5/8	1	ELBOW - Tube Fitting	
39		32		1	TUBE--5/8 O.D. x .049 x 33 1/2 Lg.--(H.D. Copper)	
40	C-9805	33	C-9805-P 5/8	1	ELBOW - Tube Fitting	
41						
42						
43						
44						
45						
46						
47						
48						
49						
50						

NAME BASE GROUP

ORIGINALLY ISSUED FOR 4 CYL. 9 x 12 MARINE

FOR TOTAL REQUIREMENTS PER ENGINE MULTIPLY NO. REQ'D GIVEN ABOVE BY NO. REQ'D FOR GROUP GIVEN ON INDEX SHEET

PARTS LIST

ATLAS IMPERIAL DIESEL ENGINE CO.
OAKLAND, CALIF. MATTOON, ILL.

L-9877

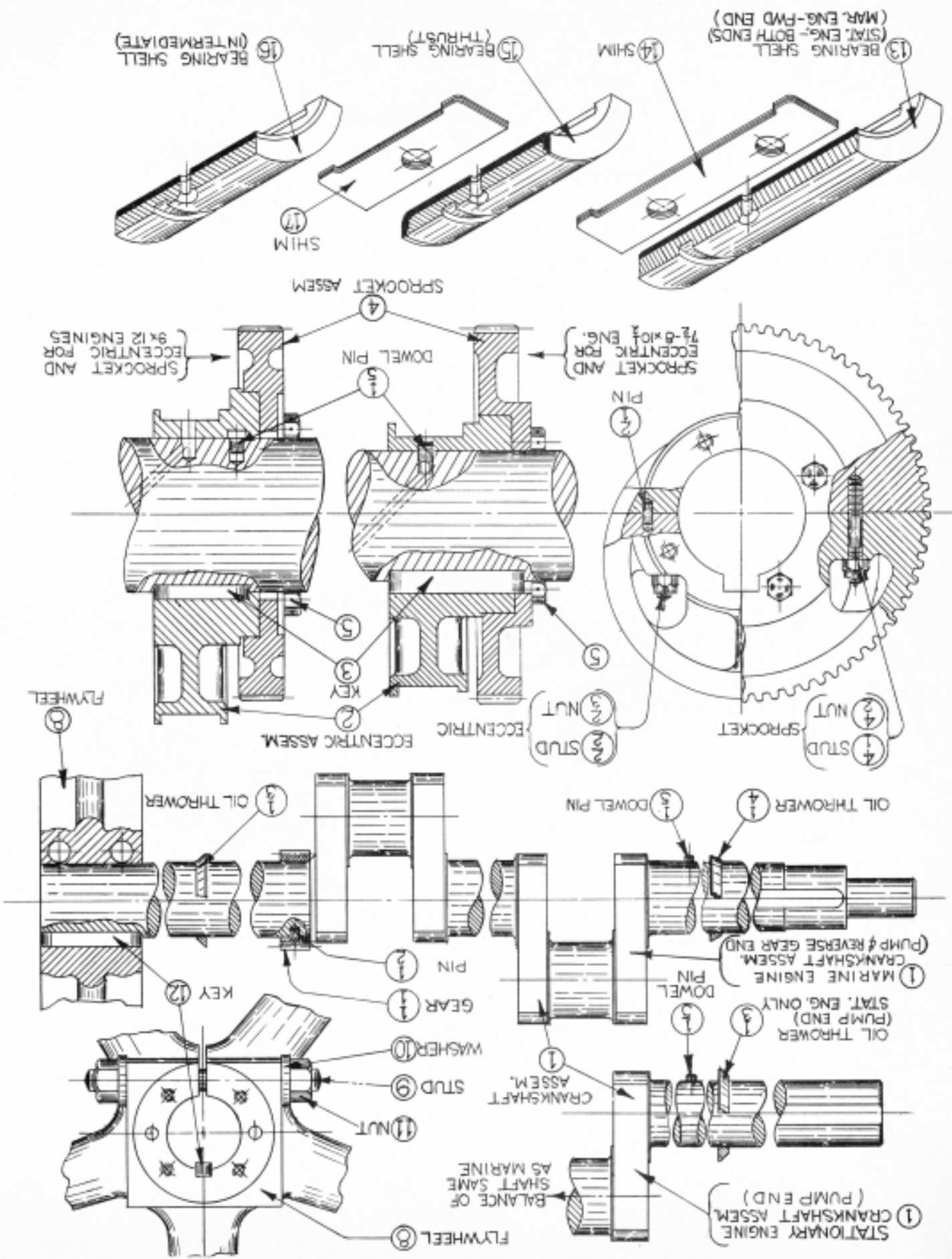

CHANGES

CHANGES

L-9879

ALWAYS GIVE PART NUMBER-PART NAME-ENGINE NUMBER
FOR STD. HARDWARE WITHOUT PART NUMBER GIVE DESCRIPTION AND SIZE
* INDICATES PART NOT SERVICED INDIVIDUALLY

PLATE NO. W-2377

LINE NO.	DRWG. NO.	REP. NO.	*	PART NO.	NO. REQD.	PART NAME	ASSEM. DRWG. NO. (W-1157 Sprocket & Eccent.)
1		1		X2288	1	CRANKSHAFT ASSEMBLY	
2	F-5286	2		X2113	1	ECCENTRIC ASSEM. - Air Compressor	
3	C-8072	3		C-8072L3	1	KEY - Eccentric to Crankshaft	
4	F-5517	4		X2270	1	SPROCKET ASSEM. - Centrif. Water Pump Drive	
5	C-2408	5		C-2408L1 1/4	4	CAPSCREW - Sprocket to Eccentric	
6					1	WIRE -- #16 Ga. x 23 Lg. - - (Steel)	
7							
8		8		W-1150	1	FLYWHEEL	
9		9		C-8512	2	STUD - Flywheel Clamp	
10		10		S-2706	4	WASHER - Flywheel Clamp Stud	
11		11			4	NUT -- 1 1/2-12-NF-Hex. - - (Steel)	
12	C-2057	12		C-2057L9 3/4	1	KEY - Flywheel to Crankshaft	
13							
14	F-5282	13		644-E32	2	SHELL - Crankshaft Bearing - (Fwd. End)	
15	C-8506	14		719A-E32-A	2	SHIM - Crank. Fwd. Bearing - (1/16)	
16	C-8506	14		719A-E32-B	4	SHIM - Crank. Fwd. Bearing - (1/32)	
17	C-8506	14		719A-E32-D	10	SHIM - Crank. Fwd. Bearing - (.010)	
18	C-8506	14		719A-E32-E	8	SHIM - Crank. Fwd. Bearing - (.003)	
19							
20	C-598	15		648-E32	2	SHELL - Crankshaft Bearing - (Thrust)	
21	C-597	16		646-E32	6	SHELL - Crankshaft Bearing	
22	C-8505	17		720A-E32-A	8	SHIM - Crankshaft Bearing - (1/16)	
23	C-8505	17		720A-E32-B	16	SHIM - Crankshaft Bearing - (1/32)	
24	C-8505	17		720A-E32-D	40	SHIM - Crankshaft Bearing - (.010)	
25	C-8505	17		720A-E32-E	32	SHIM - Crankshaft Bearing - (.003)	
26							
27							
28							
29							
30							
31							
32							
33							
34							
35							
36							
37							
38							
39							
40							
41							
42							
43							
44							
45							
46							
47							
48							
49							
50							

FOR OFF. HAND SEE

NAME CRANKSHAFT & FLYWHEEL GROUP

FOR OFF. POT. SEE

ORIGINALLY ISSUED FOR 4 CYL. 9 x 12 MARINE

FOR TOTAL REQUIREMENTS PER ENGINE MULTIPLY NO. REQ'D GIVEN ABOVE BY NO. REQ'D FOR THIS GROUP GIVEN ON INDEX SHEET

PARTS LIST

ATLAS IMPERIAL DIESEL ENGINE CO.
OAKLAND, CALIF. MATTOON, ILL.

FORM NO. 14-1-14-37

L-9879

#2 Retyped from 5-15-39 (No change)

CHANGES

CHANGES

L-9880

ALWAYS GIVE PART NUMBER—PART NAME—ENGINE NUMBER FOR STD. HARDWARE WITHOUT PART NUMBER GIVE DESCRIPTION AND SIZE * INDICATES PART NOT SERVICED INDIVIDUALLY

PLATE NO **K-2317**

LINE NO.	DRWG. NO.	REF. NO.	PART NO.	NO. REQ'D	PART NAME	ASSEM. DRWG. NO.
1	W-1111	25	X2244	1	DRUM ASSEM. - Reverse Gear	A-217 -- K-1296
2				2	PIPE PLUG -- 3/4 Std. - C't's'k. Head -- (C.I.)	
3	F-5448	26	X2243	1	COVER ASSEM. - Reverse Gear Drum	
4		27	C-8385	1	GASKET - Cover to Drum	
5				6	CAPSCREW -- 5/8-11-NC x 1 1/2 Lg. -- (St.)	
6				6	LOCKWASHER -- 5/8 SAE Reg. -- (St.)	
7		28	F-5452	1	GEAR - Reverse Gear Drive - (on Crankshaft)	
8	F-4997	29	G307-C4	3	PINION ASSEM. - Reverse Gear (Short)	
9	C-8359	30	317-C4	3	SPACER - Rev. Gear Short Pinion	
10	F-5000	31	G306-C4	3	PINION ASSEM. - Reverse Gear (Long)	
11	C-8299	32	X2238	6	SHAFT ASSEM. - Reverse Gear Pinion	
12	W-941	33	X2137	1	SHAFT ASSEM. - Thrust	
13	C-8047	34	323-C6	1	BUSHING - Thrust Shaft (Floating)	
14		35	W-942	1	COUPLING - Propeller Shaft (& Prop. Brake Drum)	
15	C-6714	36	C-6714L6	1	KEY - Coupling to Thrust Shaft	
16	C-2716	37	C-2716L7	2	BOLT - Coupling Clamp	
17				2	NUT -- 1-8-NC-Hex. -- (St.)	
18						
19		40	K-1256	1	BEARING - Thrust	
20	C-5311	41	C-5311-B	2	SHIM - Thrust Bearing to Base - (1/32)	
21	C-5311	41	C-5311-D	4	SHIM - Thrust Bearing to Base - (.010)	
22	C-5311	41	C-5311-E	8	SHIM - Thrust Bearing to Base - (.003)	
23	C-6271	42	C-6271L2 1/4	2	PIN - Bearing to Base Dowel	
24				4	CAPSCREW -- 7/8-9-NC x 2 1/2 Lg. -- (St.)	
25		43	W-939	1	CAP - Thrust Bearing	
26	C-8401	44	C-8401-A	2	SHIM - Cap to Bearing - (1/16)	
27	C-8401	44	C-8401-B	2	SHIM - Cap to Bearing - (1/32)	
28	C-8401	44	C-8401-C	4	SHIM - Cap to Bearing - (1/64)	
29	C-6271	45	C-6271L2 1/4	2	PIN - Cap to Bearing Dowel	
30				4	CAPSCREW -- 7/8-9-NC x 2 1/4 Lg. -- (St.)	
31		46	F-4396	2	PIPE - Water By-Pass	
32		47	C-5287	2	GASKET - By-Pass Pipe to Thrust Brg. & Cap	
33				4	CAPSCREW -- 1/2-13-NC x 2 Lg. -- (St.)	
34				3	PIPE PLUG -- 1 1/2 Std. -- (C.I.)	
35				1	PIPE PLUG -- 1 1/2 Std. - C't's'k. Hd. -- (C.I.)	
36				2	REDUCING BUSHING -- 1 1/2 x 1/4 Std. -- (C.I.)	
37					BABBITT - SAE #11	
38		48	F-5513	2	GUARD - Reverse Gear Drum	
39				4	CAPSCREW -- 1/2-13-NC x 7/8 Lg. -- (St.)	
40				4	LOCKWASHER -- 1/2 SAE Reg. -- (St.)	
41						
42						
43						
44						
45						
46						
47						
48						
49						
50						

NAME **REVERSE GEAR & THRUST BEARING GROUP -- (21st REV. GEAR)**

ORIGINALLY ISSUED FOR **4 CYL. 9 x 12 MARINE**

FOR TOTAL REQUIREMENTS PER ENGINE MULTIPLY NO. REQ'D GIVEN ABOVE BY NO. REQ'D FOR GROUP GIVEN ON INDEX SHEET

PARTS LIST

ATLAS IMPERIAL DIESEL ENGINE CO.
OAKLAND, CALIF. MATTOON, ILL.

L-9880

DO NOT ORDER PARTS BY REF. NUMBERS

PLATE #
K2318

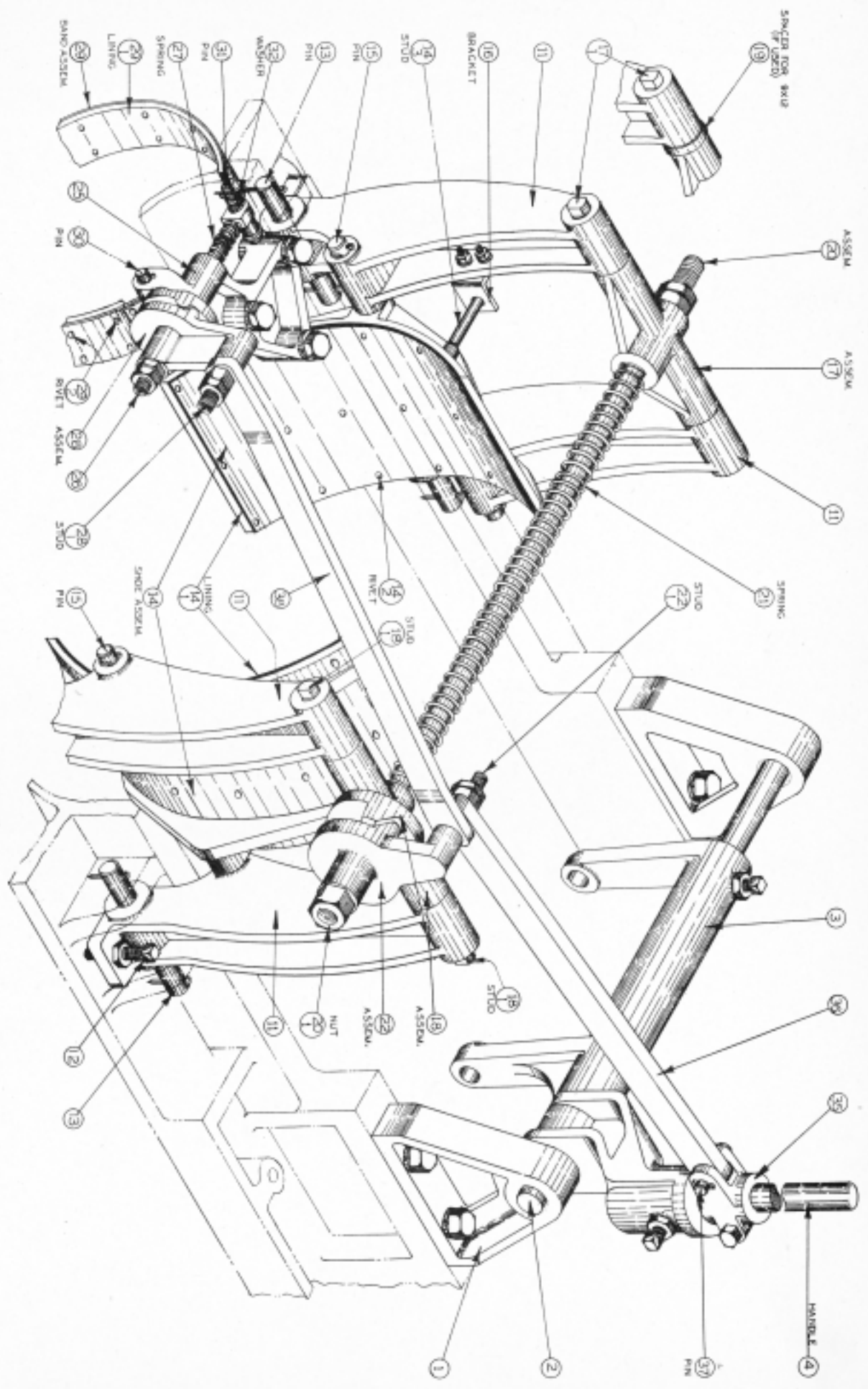

Retyped from 5-16-39 (no changes)

CHANGES
#1

CHANGES

L-9883

PLATE No. K-2318

ALWAYS GIVE PART NUMBER—PART NAME—ENGINE NUMBER
FOR STD. HARDWARE WITHOUT PART NUMBER GIVE DESCRIPTION AND SIZE

LINE NO.	DRWG. NO.	REF. NO.	PART NO.	NO. REQ'D	PART NAME	ASSEM. DRWG. NO.
1	P-5498	11	343-10	4	POST - R.G. Drum Brake Shoe	
2		12		4	SEWSCREW -- 1/2-13-NC x 3 Lg. - Sq. Hd. - Cup Pt. (St.)	
3				4	HALF NUT -- 1/2-13-NC-Hex. - - (St.)	
4		13	C-8434	4	PIN - Brake Post to Base	
5				8	COTTER PIN -- 3/16 x 1 1/2 Lg. - - (St.)	
6	C-8437	14	G342-C4	2	SHOE ASSEM. - R.G. Drum Brake	
7		15	C-8435	2	PIN - Brake Shoe to Post	
8				4	COTTER PIN -- 3/16 x 1 1/4 Lg. - - (St.)	
9		16	C-7863	2	BRACKET - Brake Shoe Centering	
10				4	CAPSCREW -- 1/4-20-NC x 5/8 Lg. - - (St.)	
11				4	LOCKWASHER -- 1/4 SAE Reg. - - (St.)	
12				4	HALF NUT (Centering Stud) -- 3/8-16-NC-Hex. - (St.)	
13		17	X2889	1	SWIVEL ASSEM. - Brake Post - (Plain)	
14		18	X2290	1	SWIVEL ASS. M. - Brake Post - (Crowder)	
15		19	C-8438	4	SPACER - Brake Post Swivel	
16	C-8433	20	X2266	1	ROD ASSEM. - Brake Post Tie	
17				1	NUT -- 7/8-9-NC-Hex. - - (St.)	
18				1	HALF NUT -- 7/8-9-NC-Hex. - - (St.)	
19	F-4410	21	345B-T3	1	SPRING - Brake Post Tie Rod	
20	C-7852	22	X2045	1	CROWDER ASSEM. - Brake Post Tie Rod	
21						
22		25	W-1307	1	BRACKET - Prop. Shaft Brake Band	
23				3	CAPSCREW -- 5/8-11-NC x 3 Lg. - - (St.)	
24				3	LOCKWASHER -- 5/8 SAE Reg. - - (St.)	
25		26	C-9930	1	EYE-BOLT - Prop. Shaft Brake Band	
26				2	HALF NUT -- 5/8-11-NC-Hex. - - (St.)	
27		27	C-7451	1	SPRING - Prop. Shaft Brake Band Eye-Bolt	
28	C-7855	28	X2047	1	CROWDER ASSEM. - Prop. Shaft Brake Band	
29	C-9550	29	X2612	1	BAND ASSEM. - Prop. Shaft Brake	
30		30	C-7857	1	PIN - Prop. Shaft Brake Band to Brake Bracket	
31				2	COTTER PIN -- 3/32 x 3/4 Lg. - - (St.)	
32		31	C-9554	1	PIN - Prop. Shaft Brake Band to Eye-Bolt	
33		32		2	PLAIN WASHER -- 1/2 SAE Std. - - (St.)	
34				2	COTTER PIN -- 1/8 x 3/4 Lg. - - (St.)	
35						
36		35	C-7810	1	CLEVIS - Brake Control Link (On Cont. Handle)	
37				1	CAPSCREW -- 1/2-13-NC x 2 Lg. - - (St.)	
38		36	C-8431	1	LINK - Rev. Gear Drum Brake Control	
39	S-184	37	1129A-HX	1	PIN - Drum Brake Control Link to Clevis	
40				2	COTTER PIN -- 1/8 x 3/4 Lg. - - (St.)	
41		38	C-8432	1	LINK - Prop. Shaft Brake Control	
42				2	NUT (Cont. Links to Crowders) -- 5/8-11-NC-Hex. - (St.)	
43				2	HALF NUT (Cont. Links to Crowders) --	
44					5/8-11-NC-Hex. - - (St.)	
45						
46						
47						
48						
49						
50						

FOR OFF. HAND SEE

L-9884

FOR OFF. NOT. SEE

NAME. REV. GEAR DRUM & PROP. SHAFT BRAKE GROUP

ORIGINALLY ISSUED FOR 4 Cyl. 9 x 12 MAR. - R.M.

FOR TOTAL REQUIREMENTS PER ENGINE MULTIPLY NO. REQ'D GIVEN ABOVE BY NO. REQ'D FOR GROUP GIVEN ON INDEX SHEET

PARTS LISTATLAS IMPERIAL DIESEL ENGINE CO.
OAKLAND, CALIF. MATTOON, ILL.

L-9883

CHANGES

CHANGES

L-9887

ALWAYS GIVE PART NUMBER-PART NAME-ENGINE NUMBER
FOR STD. HARDWARE WITHOUT PART NUMBER GIVE DESCRIPTION AND SIZE
* INDICATES PART NOT SERVICED INDIVIDUALLY

PLATE NO. K-2305

LINE NO.	DRWG. NO.	REF. NO.	* PART NO.	NO. REQ'D.	PART NAME	{ ASSEM. DRWG. NO.
1	F-5540	1	X2857	1	CENTERFRAME ASSEMBLY	
2		2	C-8510	2	GASKET - Centerframe to Base - (Side)	
3		3	C-8508	2	GASKET - Centerframe to Base - (Int. Gear End)	
4		4	C-8509	2	GASKET - Centerframe to Base - (Pump End)	
5		5	C-8507	8	GASKET - Centerframe to Base - (Inner Sect.)	
6	S-976	7	727A-KXH	1	WASHER - Base to Centerframe Stud	
7		8		1	NUT -- 1 3/8-6-NC-Hex. - - (Steel)	
8		9	C-3238	2	WASHER - Base to Centerframe Stud	
9		10		2	NUT -- 3/4-10-NC-Hex. - - (Steel)	
10	C-606	13	77B	1	FLANGE - Breather Pipe	
11		14	C-3057	1	GASKET - Flange to Centerframe	
12				2	CAPSCREW -- 1/2-13-NC x 1 1/4 Lg. - (Steel)	
13				2	LOCKWASHER -- 1/2 SAE Reg. - - (Steel)	
14		15		1	NIPPLE -- 1 1/2 x 6 Lg. - (W.I.)	
15		16		1	ELBOW -- 1 1/2 Std. - - (M.I.)	
16		25	C-9539	1	POINTER - Flywheel	
17				2	CAPSCREW -- 3/8-16-NC x 1 Lg. - (Steel)	
18				2	LOCKWASHER -- 3/8 SAE Reg. - - (Steel)	
19	F-5189	26	692-E	7	DOOR - Centerframe - (Round)	
20	C-8430	27	692A-53	7	GASKET - Door to Centerframe	
21				28	CAPSCREW -- 1/2-13-NC x 1 1/2 Lg. - (Steel)	
22				28	LOCKWASHER -- 1/2 SAE Reg. - - (Steel)	
23		28	W-905	1	COVER - Centerframe End & Crank. Bearing (Gov. End)	
24		29	F-5242	1	GASKET - Cover to Centerframe & Base	
25				10	CAPSCREW -- 1/2-13-NC x 1 1/4 Lg. - (Steel)	
26				10	LOCKWASHER -- 1/2 SAE Reg. - - (Steel)	
27	C-7950	30	C-7950L1 1/2	1	PIN - Cover to Centerframe Dowel	
28				1	CASTLE NUT -- 3/8-24-NF-Hex. - - (Steel)	
29				1	COTTER PIN -- 3/32 x 3/4 Lg. - (Steel)	
30		31	F-5520	1	COVER - Centerframe Aft. End	
31		32	C-8489	1	GASKET - Cover to Centerframe	
32				6	CAPSCREW -- 1/2-13-NC x 1 1/4 Lg. - (Steel)	
33				6	LOCKWASHER -- 1/2 SAE Reg. - - (Steel)	
34						
35						
36						
37						
38						
39						
40						
41						
42						
43						
44						
45						
46						
47						
48						
49						
50						

FOR OFF. HAND SEE

L-9888

FOR OFF. ROT. SEE

NAME CENTERFRAME & COVERS GROUP

ORIGINALLY ISSUED FOR 4 CYL. 6 x 12 MARINE - R.H.

FOR TOTAL REQUIREMENTS PER ENGINE MULTIPLY NO. REQ'D GIVEN ABOVE BY NO. REQ'D FOR THIS GROUP GIVEN ON INDEX SHEET

PARTS LIST

ATLAS IMPERIAL DIESEL ENGINE CO.
OAKLAND, CALIF. MATTOON, ILL.

L-9887

EXTRA COPIES TO

TYPED BY DLB DATE 4-9-45

CHECKED *meb* DATE 4-30-45

ISSUED BY *DK* APRVD.

#1 Retyped from 5-15-39 (No changes)

CHANGES

CHANGES

L-9889

ALWAYS GIVE PART NUMBER—PART NAME—ENGINE NUMBER
FOR STD. HARDWARE WITHOUT PART NUMBER GIVE DESCRIPTION AND SIZE
* INDICATES PART NOT SERVICED INDIVIDUALLY

PLATE NO. K-2077 (Ed 2)

LINE NO.	DRWG. NO.	REF. NO.	PART NO.	NO. REQD.	PART NAME	ASSEM. DRWG. NO.
1	W-1140	1	G600-PB42	1	CYLINDER ASSEMBLY	
2	S-976	2	727A-KXH	4	WASHER - Cyl. to Centerframe Stud	
3		3		4	NUT -- 1 3/8-6-NC-Hex. - - (St.)	
4						
5		4	X2292	1	HEAD ASSEM. - Cylinder	
6		5	C-3831	1	GASKET - Head to Cylinder	
7	S-803	6	610A-RB3	6	GROMMET - Cyl. to Head Water By-Pass Pipe	
8		7		6	NUT -- 1 1/4-7-NC-Hex. - - (St.)	
9						
10		8	C-8417	1	PLUG-Compression Release & Safety Valve Adaptor	
11	C-354	9	G1197-E1	1	VALVE ASSEM. - Compression Release (Snifter)	
12	S-3340	10	X204	1	VALVE ASSEM. - Cyl. Pressure Relief Safety	
13						
14						
15						
16						
17						
18						
19						
20						
21						
22						
23						
24						
25						
26						
27						
28						
29						
30						
31						
32						
33						
34						
35						
36						
37						
38						
39						
40						
41						
42						
43						
44						
45						
46						
47						
48						
49						
50						

FOR OFF-HAND SEE

NAME **CYLINDER & HEAD GROUP**

FOR OFF. NOT. SEE

ORIGINALLY ISSUED FOR **3-4 CYL. 9 x 12 MARINE**

FOR TOTAL REQUIREMENTS PER ENGINE MULTIPLY NO. REQ'D GIVEN ABOVE BY NO. REQ'D FOR GROUP GIVEN ON INDEX SHEET

PARTS LIST

ATLAS IMPERIAL DIESEL ENGINE CO.
OAKLAND, CALIF. MATTOON, ILL.

L-9889-7

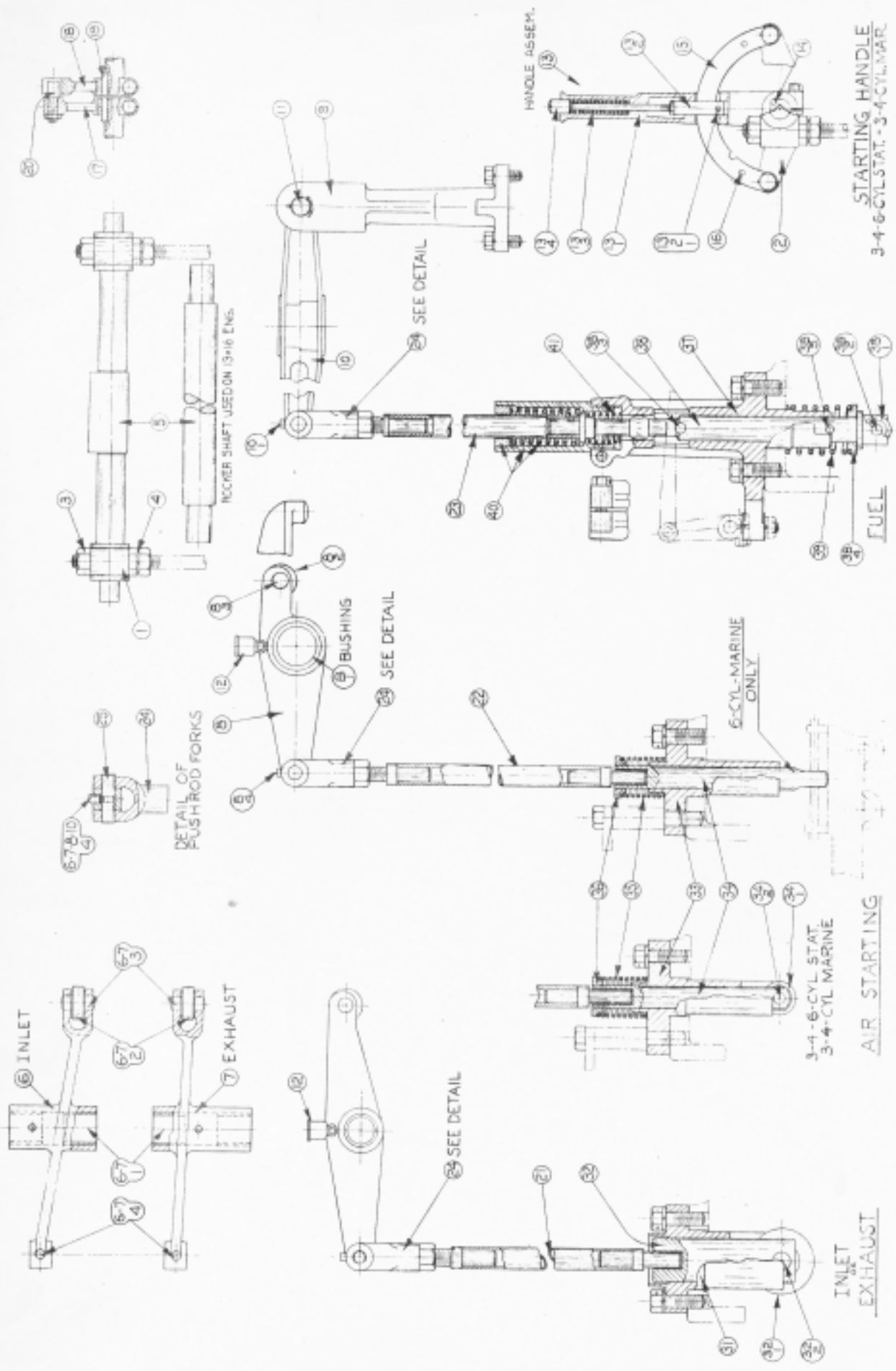

#3 Retyped from 5-15-39 (No changes)

CHANGES

CHANGES

ALWAYS GIVE PART NUMBER—PART NAME—ENGINE NUMBER
FOR STD. HARDWARE WITHOUT PART NUMBER GIVE DESCRIPTION AND SIZE
* INDICATES PART NOT SERVICED INDIVIDUALLYL-9892
PLATE NO. K-1926

LINE NO.	DRWG. NO.	REP. NO.	PART NO.	NO. REQD.	PART NAME	ASSEM. DRWG. NO.
1	S-2846	1	38-R8	7	BEARING - Valve Rocker Shaft	
2	F-3017	2	566-E3	1	BEARING - Valve Rocker Shaft	
3		3		16	NUT -- 5/8-11-NC-Hex. - - (St.)	
4		4		16	LOCKNUT -- Drake - 5/8-11-NC-Hex. - (St.)	
5	F-5480	5	565-E1	4	SHAFT - Valve Rocker	
6	F-5474	6	G520-E32	4	ROCKER ASSEM. - Inlet Valve	
7	F-5476	7	G550-E32	4	ROCKER ASSEM. - Exhaust Valve	
8	F-5478	8	G590-E32	4	ROCKER ASSEM. - Air Start. Valve	
9						
10	F-3089	9	872-E1	4	STAND - Fuel Spray Valve Rocker	
11				8	CAPSCREW -- 1/2-13-NC x 1 1/4 Lg. - (St.)	
12				8	LOCKWASHER -- 1/2 SAE Reg. - - (St.)	
13		10	X1306	4	ROCKER ASSEM. - Fuel Spray Valve	
14	S-2448	11	873-H	4	PIN - Spray Valve Rocker to Stand	
15				8	COTTER PIN -- 3/32 x 1 1/2 Lg. - (St.)	
16						
17		12		12	OIL CUP--Bowen No. 5 - Hinged Lid - 1/8 P.T.(St.)	
18						
19		13	G570-C31	1	HANDLE ASSEM. - Air Starting	
20	S-3137	14	5123	1	KEY - Handle to Rocker Shaft	
21	S-2285	15	573-C3	1	SECTOR - Air Starting Handle	
22		16		2	TAPER PIN(Handle Stop)--No. 3 x 1 Lg.--(St.)	
23				2	CAPSCREW -- 1/2-13-NC x 7/8 Lg. - (St.)	
24				2	LOCKWASHER -- 1/2 SAE Reg. - - (St.)	
25	C-832	17	564A-E	3	CRANK - Rocker Shaft Connecting (Male)	
26	S-1415	18	564-E	3	CRANK - Rocker Shaft Connecting (Female)	
27	S-3137	19	5123	6	KEY - Crank to Rocker Shaft	
28				6	CAPSCREW -- 3/8-16-NC x 1 3/4 Lg. - (St.)	
29	S-2688	20	564B-E	3	PIN - Rocker Shaft Connect. Crank Drive	
30				3	HALF NUT -- 3/8-16-NC-Hex. - - (St.)	
31						
32	S-2749	21	525-E	8	PUSH-ROD - Inlet & Exhaust Valve	
33	S-2750	22	593-E	4	PUSH-ROD - Air Starting Valve	
34	F-4405	23	X1341	4	PUSH-ROD ASSEM. - Fuel Spray Valve	
35	C-281	24	526-R	16	FORK - Push-Rod to Valve Rocker Connecting	
36				16	NUT -- 3/4-16-NF-Hex. - - (St.)	
37	S-748	25	527-E1	16	PIN - Fork to Valve Rocker	
38						
39						
40						
41						
42						
43						
44						
45						
46						
47						
48						
49						
50						

FOR OFF. HAND SEE

L-9893

FOR OFF. COPY SEE

NAME VALVE ROCKER & PUSH-ROD GROUP

ORIGINALLY ISSUED FOR 4 CYL. 9 x 12 MARINE - R.H.

FOR TOTAL REQUIREMENTS PER ENGINE MULTIPLY NO. REQ'D GIVEN ABOVE BY NO. REQ'D FOR GROUP GIVEN ON INDEX SHEET

PARTS LIST

ATLAS IMPERIAL DIESEL ENGINE CO.
OAKLAND, CALIF. MATTOON, ILL.

L-9892

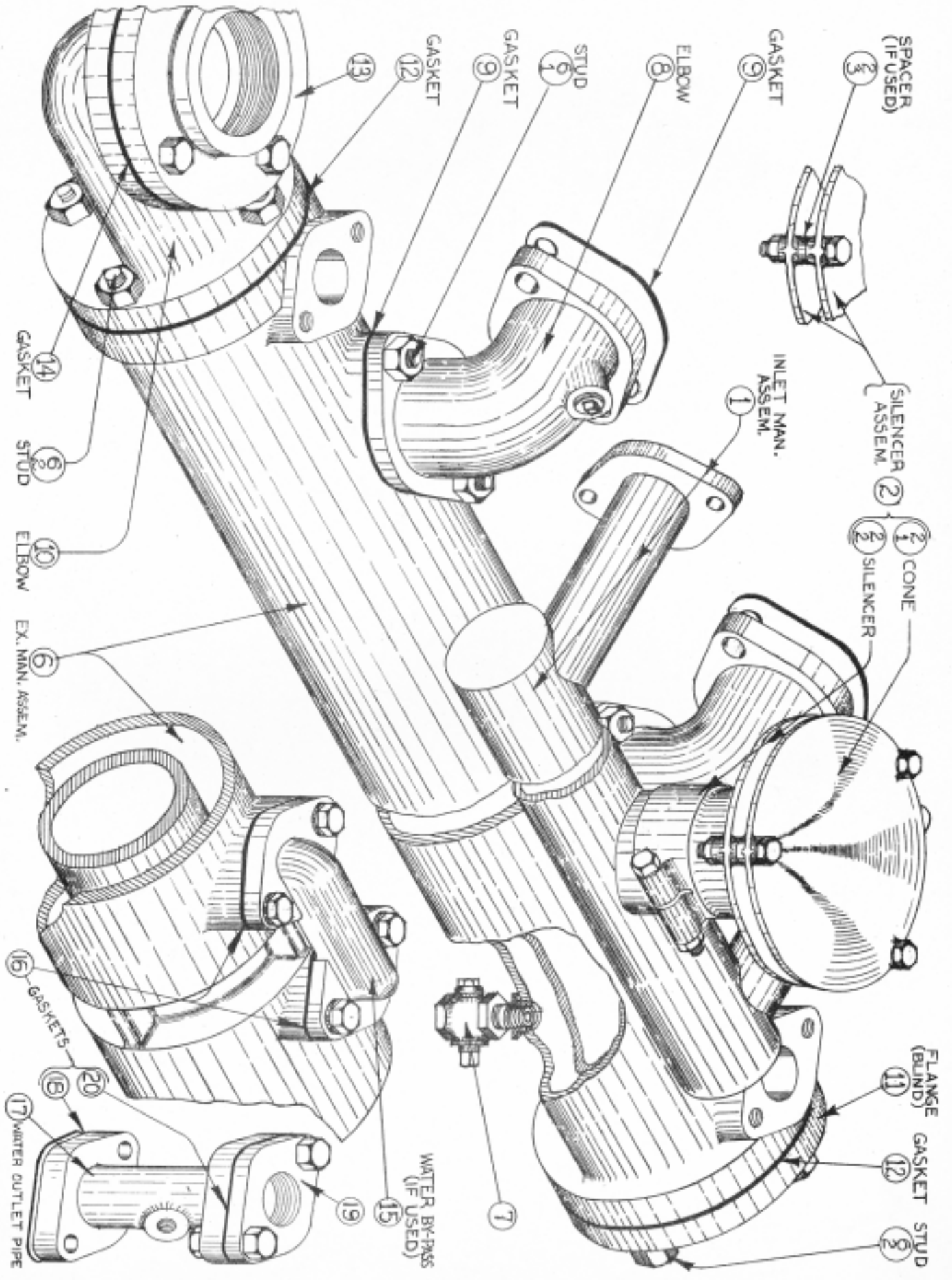

CHANGES #1

5-3-45 Lines 26 to 34 Incl. added

CHANGES

L-9895

ALWAYS GIVE PART NUMBER-PART NAME-ENGINE NUMBER FOR STD. HARDWARE WITHOUT PART NUMBER GIVE DESCRIPTION AND SIZE & INDICATES PART NOT SERVICED INDIVIDUALLY

PLATE NO. W-2384

LINE NO.	DRWG. NO.	REF. NO.	PART NO.	NO. REQ'D.	PART NAME	ASSEM. DRWG. NO.
1	F-5509	1	X2269	1	MANIFOLD ASSEM. - Air Inlet	
2				8	CAPSCREW -- 1/2-13-NC x 1 1/4 Lg. - (Steel)	
3				8	LOCKWASHER -- 1/2 SAE Reg. - - (Steel)	
4		2	X368	1	SILENCER ASSEM. - Air Suction	
5						
6						
7	W-1142	6	X2297	1	MANIFOLD ASSEM. - Exhaust	
8				2	CLOSE NIPPLE -- 1/2 Std. - - (Brass)	
9	C-9053	7	C-9053-P ₁	2	COCK - Exhaust Manifold Drain	
10	C-630	8	398-R6	4	ELBOW - Cyl. Head Exhaust Outlet	
11				4	PIPE PLUG -- 1/2 Std. - - (C.I.)	
12		9	S-3287	8	GASKET - Elbow to Manifold & Cyl. Head	
13				16	NUT -- 5/8-11-NC-Hex. - - (Steel)	
14		10	F-5527	1	ELBOW - Ex. Manifold Exhaust Outlet	
15	C-4023	11	763-C3	1	FLANGE - Exhaust Manifold End (Blind)	
16	S-919	12	760A-R10	2	GASKET - Elbow & Flange to Manifold	
17				8	NUT -- 5/8-11-NC-Hex. - - (Steel)	
18		13	C-1381	1	FLANGE - Exhaust Outlet Pipe	
19	S-919	14	760A-R10	1	GASKET - Flange to Elbow	
20				4	CAPSCREW -- 5/8-11-NC x 2 1/2 Lg. - (Steel)	
21				4	NUT -- 5/8-11-NC-Hex. - - (Steel)	
22	F-2819	15	792-EX6	1	PIPE - Water By-Pass	
23		16	S-2334	2	GASKET - By-Pass Pipe to Manifold	
24				4	CAPSCREW -- 1/2-13-NC x 1 1/4 Lg. - (Steel)	
25				4	LOCKWASHER -- 1/2 SAE Reg. - - (Steel)	
26	C-7946	17	791-C	1	PIPE - Ex. Man. Water Outlet	
27		18	S-1042	1	GASKET - Pipe to Ex. Manifold	
28				2	CAPSCREW -- 1/2-13-NC x 1 1/2 Lg. - (St.)	
29				2	LOCKWASHER -- 1/2 SAE Reg. - - (St.)	
30	C-5351	19	786-B	1	FLANGE - Ex. Man. Water Outlet Pipe	
31		20	S-1042	1	GASKET - Flange to Pipe	
32				2	CAPSCREW -- 1/2-13-NC x 2 Lg. - (St.)	
33				2	NUT -- 1/2-13-NC-Hex. - - (St.)	
34				2	LOCKWASHER -- 1/2 SAE Reg. - - (St.)	
35						
36						
37						
38						
39						
40						
41						
42						
43						
44						
45						
46						
47						
48						
49						
50						

FOR OFF. HAND SEE 2L1397 FOR OFF. NOT. SEE

NAME INLET & EXHAUST MANIFOLD GROUP
 ORIGINALLY ISSUED FOR 4 CYL. 9 x 12 MAR.-STAT. R.H.
 FOR TOTAL REQUIREMENTS PER ENGINE MULTIPLY NO. REQ'D GIVEN ABOVE BY NO. REQ'D FOR THIS GROUP GIVEN ON INDEX SHEET

PARTS LIST ATLAS IMPERIAL DIESEL ENGINE CO. OAKLAND, CALIF. MATTOON, ILL.

L-9895

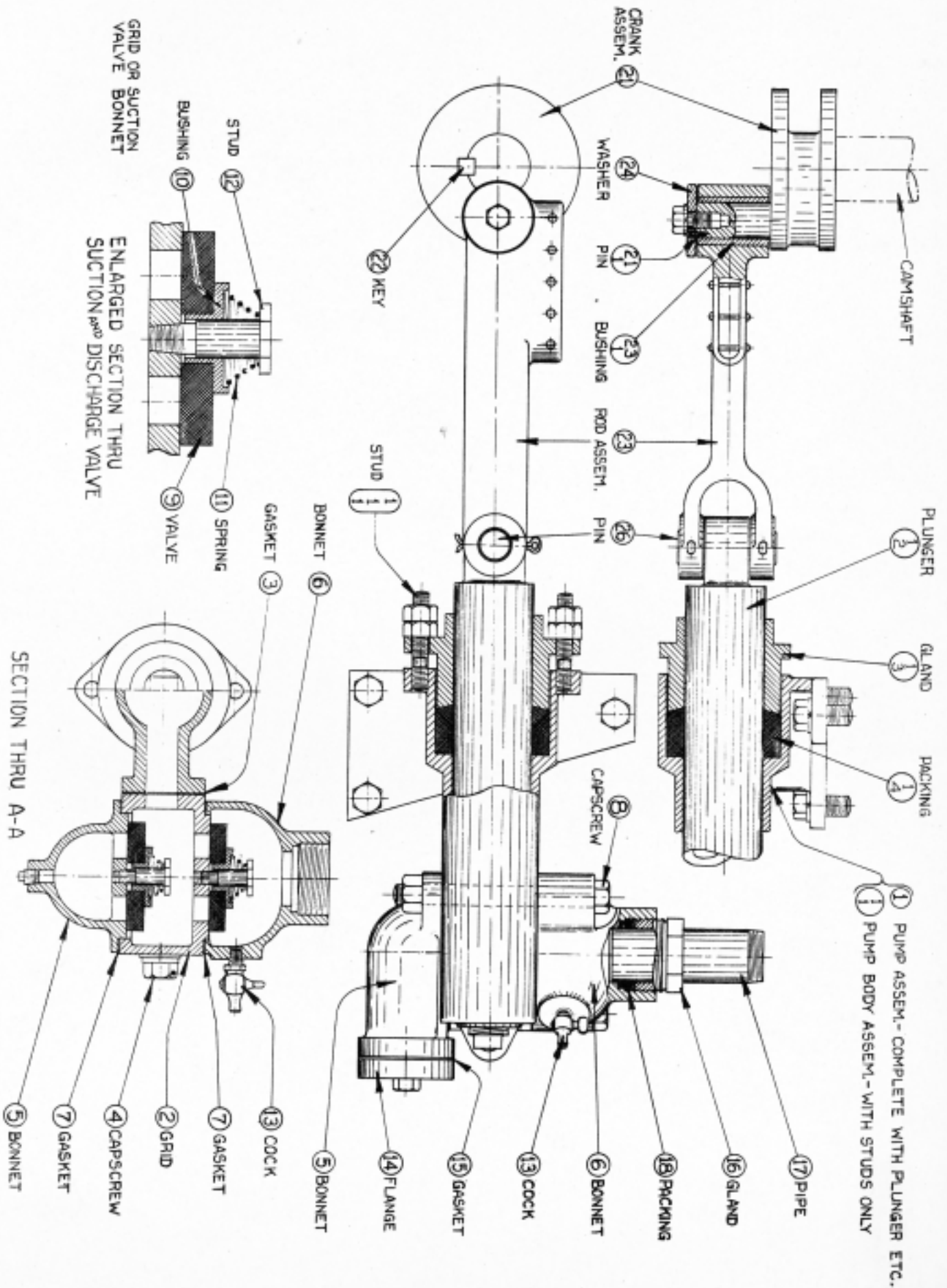

#1 7-5-39 Line 11 Part No. Was C-487
Line 12 No. Req'd. Was 4

CHANGES

CHANGES

L-9902

ALWAYS GIVE PART NUMBER-PART NAME-ENGINE NUMBER
FOR STD. HARDWARE WITHOUT PART NUMBER GIVE DESCRIPTION AND SIZE
* INDICATES PART NOT SERVICED INDIVIDUALLY

PLATE NO. W-2434

LINE NO.	DRWG. NO.	REF. NO.	*	PART NO.	NO. REQ'D.	PART NAME	ASSEM. DRWG. NO.
1		1		X1229	1	PUMP ASSEM. - Bilge	
2					3	CAPSCREW -- 5/8-11-NC x 1 1/4 Lg. - (Steel)	
3					3	LOCKWASHER -- 5/8 SAE Reg. - - (Steel)	
4	W-23	2		214-E	1	GRID - Bilge Pump Valve	
5		3		C-1217	1	GASKET - Grid to Pump Body	
6	C-2410	4		C-2410L5 3/4	2	CAPSCREW - Grid to Pump Body	
7					2	LOCKWASHER -- 5/8 SAE Reg. - - (Steel)	
8	F-2892	5		215-29	1	BONNET - Bilge Pump Suction Valve	
9		6		C-9161	1	BONNET - Bilge Pump Discharge Valve	
10	S-2050	7		215A-E	2	GASKET - Bonnets to Grid	
11		8			2	CAPSCREW -- 5/8-11-NC x 6 Long -(Steel)	
12					2	NUT -- 5/8-11-NC-Hex. - - (Steel)	
13	S-1788	9		219-E1	2	VALVE - Bilge Pump Suction & Discharge	
14	S-2289	10		219A-6	2	BUSHING - Bilge Pump Valve	
15	C-461	11		218-E	2	SPRING - Bilge Pump Valve	
16	S-2046	12		217-7	2	STUD - Bilge Pump Valve	
17	C-9045	13		C-9045-P 1/4	1	COCK - Tee Handle Air (Discharge Bonnet)	
18					1	PIPE PLUG -- 1/4 Std. - - (Brass)	
19	C-5351	14		786-B	1	FLANGE - Bilge Pump Suction Pipe	
20		15		S-1042	1	GASKET - Flange to Pump Bonnet	
21					2	CAPSCREW -- 1/2-13-NC x 1 1/4 Lg. - (Steel)	
22		16		C-8115	1	GLAND - Discharge Bonnet Packing	
23		17			1	PIPE--1 1/2 x 5 3/4 Lg. (Thr'd. one End)-(Brass)	
24		18			1	PACKING -- 1/4 Sq. x 19 Lg. -(Flax)	
25							
26	C-7971	21		X2104	1	CRANK ASSEM. - Bilge Pump Drive	
27	S-3234	22		5354	1	KEY - Crank to Camshaft	
28	F-5491	23		G264-E	1	ROD ASSEM. - Bilge Pump Connecting	
29		24		C-8004	1	WASHER - Connect. Rod Retainer	
30					1	CAPSCREW -- 1/2-13-NC x 7/8 Lg. - (Steel)	
31					1	LOCKWASHER -- 1/2 SAE Reg. - - (Steel)	
32	S-2002	26		264B-E	1	PIN - Connect. Rod to Pump Plunger	
33					2	COTTER PIN -- 3/16 x 2 1/2 Lg. - (Steel)	
34							
35							
36							
37							
38							
39							
40							
41							
42							
43							
44							
45							
46							
47							
48							
49							
50							

FOR OFF. HAND SEE L-9903

NAME BILGE PUMP GROUP

ORIGINALLY ISSUED FOR 3-4 CYL. 9 x 12 MARINE - R.H.

FOR TOTAL REQUIREMENTS PER ENGINE MULTIPLY NO. REQ'D GIVEN ABOVE BY NO. REQ'D FOR THIS GROUP GIVEN ON INDEX SHEET

PARTS LIST

ATLAS IMPERIAL DIESEL ENGINE CO. OAKLAND, CALIF. MATTOON, ILL.

L-9902

CHANGES

CHANGES

L-9906

ALWAYS GIVE PART NUMBER-PART NAME-ENGINE NUMBER
FOR STD. HARDWARE WITHOUT PART NUMBER GIVE DESCRIPTION AND SIZE
* INDICATES PART NOT SERVICED INDIVIDUALLY

PLATE NO. W-2112

LINE NO.	DRWG. NO.	REF. NO.	*	PART NO.	NO. REQ'D	PART NAME	ASSEM. DRWG. NO. K-1662
1	F-5188	1		X2066	1	DOOR ASSEM. - Rotary Pump	
2		2		C-8379	1	GASKET - Door to Centerframe	
3					6	CAPSCREW -- 1/2-13-NC x 1 1/2 Lg. - (Steel)	
4					6	LOCKWASHER -- 1/2 SAE Reg. - - (Steel)	
5		3		C-3190	2	PIN - Door to Centerframe Dowel	
6							
7	C-7400	6		X1814	1	SHAFT ASSEM. - Pump Drive	
8	F-938	7		1352-FB4	1	GEAR - Pump Drive	
9		8		C-7415	1	KEY - Gear to Shaft	
10	C-9034	9		5895	1	BALL BEARING - Drive Shaft (Small)	
11	C-9037	10		4956	1	BALL BEARING - Drive Shaft (Large)	
12		11		X1851	1	COVER ASSEM. - Pump Drive Shaft Bearing (End)	
13		12		C-7401	1	GASKET - Cover to Pump Door	
14					4	MACHINE SCREW--1/4-20 x 1/2 Lg.-Rnd. Hd.(Steel)	
15							
16	C-9039	15		G1338-RB31	1	PUMP ASSEM. - Fuel Transfer	
17		16		X2825	1	PUMP ASSEM. - Lube Oil Sump & Pressure	
18		16		C-6675	1	GASKET - Pump to Door	
19					2	CAPSCREW -- 1/2-13-NC x 1 Lg. - (Steel)	
20					2	LOCKWASHER -- 1/2 SAE Reg. - - (Steel)	
21							
22							
23						--- Fuel Transfer Pump Suction ---	
24					1	NIPPLE -- 1/4 x 2 Lg. - (Brass)	
25					1	TEE -- 1/2 x 1/4 x 1/2 Std. Reducing - (M.I.)	
26					1	PIPE PLUG -- 1/2 Std. - - (C.I.)	
27							
28							
29						--- Lube Oil Pressure Pump Suction ---	
30					1	NIPPLE -- 1/2 x 2 Lg. - (Brass)	
31					1	TEE -- 1/2 x 1 x 1 Std. Reducing - (M.I.)	
32					1	PIPE PLUG -- 1 Std. - - (C.I.)	
33							
34							
35						--- Sump Pump Suction Line (Base to Pump) ---	
36					1	NIPPLE -- 3/4 x 2 Lg. - (Brass)	
37					1	UNION -- 3/4 Std. (Crane #519 or Eq.)-(M.I.)	
38					1	PIPE -- 3/4 x 25 Lg. - (Brass)	
39					1	UNION TEE -- 3/4 Std.(Crane #598 or Eq.)-(M.I.)	
40					1	PIPE PLUG -- 3/4 Std. - - (C.I.)	
41					1	NIPPLE -- 3/4 x 2 Lg. - (Brass)	
42							
43						--- Sump Pump Discharge ---	
44					1	STREET ELL -- 3/4 Std. - - (M.I.)	
45							
46							
47							
48							
49							
50							

FOR OFF. HAND SEE

L-9907

FOR OFF. ROT. SEE

NAME LUBE OIL & FUEL TRANSFER PUMP GROUP

ORIGINALLY ISSUED FOR 4 CYL. 9 x 12 MARINE - R.H.

FOR TOTAL REQUIREMENTS PER ENGINE ML. MULTIPLY NO. REQ'D GIVEN ABOVE BY NO. REQ'D FOR THIS GROUP GIVEN ON INDEX SHEET

PARTS LIST

ATLAS IMPERIAL DIESEL ENGINE CO.
OAKLAND, CALIF. MATTOON, ILL.

90667

EXTRA COPIES TO

TYPED BY DIB DATE 4-12-45

CHKD

WEB

DATE 4-30-45

ISSUED

6/2/45

APRVD.

#3 Retyped from 5-16-39 (No changes)

CHANGES

CHANGES

L-9909

ALWAYS GIVE PART NUMBER—PART NAME—ENGINE NUMBER
FOR STD. HARDWARE WITHOUT PART NUMBER GIVE DESCRIPTION AND SIZE
* INDICATES PART NOT SERVICED INDIVIDUALLY

PLATE NO. K-2162

LINE NO.	DRWG. NO.	REF. NO.	PART NO.	NO. REQD.	PART NAME	ASSEM. DRWG. NO.
1	F-7124	1	X3726	1	RAIL ASSEM. - Fuel	
2	S-2238	2	G1203-AX3	4	CLAMP ASSEM. - Fuel Rail Support	
3				4	CAPSCREW -- 1/2-13-NC x 1 1/4 Lg. - (St.)	
4				4	LOCKWASHER -- 1/2 SAE Reg. - - (St.)	
5						
6					--- High Press. Fuel Piping ---	
7	S-3178	3	X138	1	TUBE ASSEM. - Pump to Reg. Valve - (12")	
8	S-3178	4	X138	1	TUBE ASSEM. - Pump to Pump - (12")	
9	S-3178	5	X5013	1	TUBE ASSEM. - Pump to Rail - (20")	
10	S-3178	6	X5045	4	TUBE ASSEM. - Rail to Spray Valve - (24")	
11	S-3178	7	X5045	1	TUBE ASSEM. - Rail to Accumulator - (24")	
12	S-3178	8	X5013	1	TUBE ASSEM. - Accum. to Press. Gage - (20")	
13						
14	F-6456	11	X3233	1	ACCUMULATOR ASSEM. - Fuel Oil	
15				2	CAPSCREW -- 1/2-13-NC x 1 1/4 Lg. - (St.)	
16				2	LOCKWASHER -- 1/2 SAE Reg. - - (St.)	
17		12	G1215-E	1	VALVE ASSEM. - Accumulator	
18						
19	W-28	15	G1230-E1	1	VALVE ASSEM. - Fuel Press. Regulating	
20						
21						
22						
23						
24						
25						
26						
27						
28						
29						
30						
31						
32						
33						
34						
35						
36						
37						
38						
39						
40						
41						
42						
43						
44						
45						
46						
47						
48						
49						
50						

NAME HIGH PRESSURE FUEL SYSTEM GROUP

ORIGINALLY ISSUED FOR 4 CYL. 9 x 12 MARINE

FOR TOTAL REQUIREMENTS PER ENGINE MULTIPLY NO. REQ'D GIVEN ABOVE BY NO. REQ'D FOR GROUP GIVEN ON INDEX SHEET

PARTS LIST

ATLAS IMPERIAL DIESEL ENGINE CO.
OAKLAND, CALIF. MATTOON, ILL.

6066-7

#1 5-19-43 Added Union Fitt. Part No.

CHANGES

CHANGES

L-9913

ALWAYS GIVE PART NUMBER-PART NAME-ENGINE NUMBER
FOR STD. HARDWARE WITHOUT PART NUMBER GIVE DESCRIPTION AND SIZE
* INDICATES PART NOT SERVICED INDIVIDUALLY

PLATE NO.

ASSEM. DRWG. NO. A-219 -- A-218

LINE NO.	DRWG. NO.	REF. NO.	*	PART NO.	NO. REQ'D.	PART NAME
1						--- Pressure Pump to Base & Filter ---
2					1	NIPPLE -- 1/2 x 2 1/2 Lg. - (Brass)
3	2C167			2C167-P 1/2	1	UNION TEE
4					1	TUBE(to Filter)--5/8 ODX .049x 24 Lg.(H.D. Cop.)
5	C-9804			C-9804-P 5/8	2	ELBOW - Tube Fitting
6					1	REDUCING BUSHING -- 1 x 1/2 Std. - (C.I.)
7					1	CLOSE NIPPLE -- 1/2 Std. - - (Brass)
8					1	TEE -- 1/2 Std. - - (M.I.)
9					1	NIPPLE -- 1/2 x 2 1/2 Lg. - (Brass)
10				PG 21L 1/2	1	VALVE - Pressure Relief
11					1	NIPPLE -- 1/2 x 9 Lg. - (Brass)
12	2C160			2C160-P 1/2	1	UNION ELBOW
13						
14						--- Filter to Camshaft Bearing ---
15					1	REDUCING BUSHING -- 1 x 3/8 Std. - (C.I.)
16					1	CLOSE NIPPLE -- 3/8 Std. - - (Brass)
17					1	TEE -- 1/4 x 1/4 x 3/8 Std. Reducing - (M.I.)
18					1	REDUCING BUSHING -- 1/4 x 1/8 Std. - (C.I.)
19					1	TUBE -- 1/4 O.D. x .030 x 12 Lg.--(S.D. Copper)
20	C-9801			C-9801-P 1/4	1	CONNECTOR - Tube Fitting
21	C-9804			C-9804-P 1/4	1	ELBOW - Tube Fitting
22						
23						--- Filter to Top of C't'rframe & Cent Pump Brg. ---
24					1	TUBE(Filter to top of Centerframe)--3/8 O.D. x .035 x 20 Lg. - (S.D. Copper)
25						
26	C-9801			C-9801-P 3/8	1	CONNECTOR - Tube Fitting
27	C-9805			C-9805-P 3/8	1	ELBOW - Tube Fitting
28					1	NIPPLE -- 1/4 x 5 1/2 Lg. - (Brass)
29					1	TEE -- 1/4 Std. - - (M.I.)
30					1	REDUCING BUSHING -- 1/4 x 1/8 Std. - (C.I.)
31					1	TUBE(Cent. Pump)--1/2 ODX .030x 38 Lg.--(S.D. Cop.)
32	C-9804			C-9804-P 1/4	2	ELBOW - Tube Fitting
33					1	PIPE -- 1/4 x 63 1/2 Lg.(Thr'd. 2 Ends)-(Brass)
34					1	TEE -- 1/4 x 1/4 x 1/8 Std. Reducing - (M.I.)
35				S-2809	2	CLAMP - Pipe
36					2	MACHINE SCREW--1/2-20 x 1/2 Lg. - Rnd. Hd.--(Steel)
37						
38						--- Tee on Top of C't'rframe to Gov-Int Gear & Cam Brg ---
39					1	TUBE(Gov.)--1/2 ODX .030x 14 Lg.--(S.D. Copper)
40	C-9801			C-9801-P 1/4	2	CONNECTOR - Tube Fitting
41					1	TUBE(Int. Gear)--1/2 ODX .030x 18 Lg.--(S.D. Cop.)
42					1	TUBE(Cam. Brg.)--1/2 ODX .030x 15 Lg.--(S.D. Cop.)
43	C-9807			C-9807-P 1/4	1	TEE - Tube Fitting
44					1	REDUCING BUSHING -- 1/4 x 1/8 Std. - (C.I.)
45	C-9804			C-9804-P 1/4	2	ELBOW - Tube Fitting
46						
47						
48						
49						
50						

L-9913

FOR OFF. HAND SEE

FOR OFF. ACT. SEE

FORM NO. 24-15-16-17

NAME LUBE OIL PRESSURE PIPING GROUP
ORIGINALLY ISSUED FOR 4 CYL. 9 x 12 MARINE

FOR TOTAL REQUIREMENTS PER ENGINE MULTIPLY NO. REQ'D GIVEN ABOVE BY NO. REQ'D FOR THIS GROUP GIVEN ON INDEX SHEET

PARTS LIST

ATLAS IMPERIAL DIESEL ENGINE CO.
OAKLAND, CALIF. MATTOON, ILL.

#1 Retyped From Sheet Dated 5-31-39
 #2 5-19-43 Added Union Fitt. Part Nos.

CHANGES

CHANGES

L-9915

ALWAYS GIVE PART NUMBER - PART NAME - ENGINE NUMBER
 FOR STD. HARDWARE WITHOUT PART NUMBER GIVE DESCRIPTION AND SIZE
 * INDICATES PART NOT SERVICED INDIVIDUALLY

PLATE NO.

LINE NO.	DRWG. NO.	REF. NO. *	PART NO.	NO. REQD.	PART NAME	ASSEM. DRWG. NO. A-218
1					--- Bilge Pump Nipple to Water Inlet Man. ---	
2	C-9054		C-9054-P 1/4	1	COCK - Three Way	
3				1	NIPPLE -- 1 1/4 x 7 Lg. - (Brass)	
4				1	ELBOW -- 1 1/4 Std. - - (Brass)	
5				1	NIPPLE -- 1 1/4 x 2 Lg. - (Brass)	
6						
7					--- Cent. Water Pump to Water Inlet Man. ---	
8				1	NIPPLE -- 1 1/4 x 12 Lg. - (Brass)	
9				1	ELBOW -- 1 1/4 Std. - - (Brass)	
10				1	NIPPLE -- 1 1/4 x 2 Lg. - (Brass)	
11						
12					--- Water Inlet Man. to Thrust Bearing ---	
13				1	STREET ELL -- 3/8 Std. - - (Brass)	
14				1	REDUCING BUSHING -- 3/8 x 1/4 Std. - (Brass)	
15				1	NIPPLE -- 1/4 x 5 1/2 Lg. - (Brass)	
16	C-9053		C-9053-P 1/4	1	SERVICE COCK	
17				1	NIPPLE -- 1/4 x 1 1/2 Lg. - (Brass)	
18	2C162		2C162-P 1/4	1	UNION ELBOW	
19						
20				1	PIPE -- 1/4 x 81 Lg. (Thr'd. 2 Ends) - (Brass)	
21				1	ELBOW -- 1/4 Std. - - (Brass)	
22				1	NIPPLE -- 1/4 x 8 Lg. - (Brass)	
23	2C159		2C159-P 1/4	1	UNION	
24				1	NIPPLE -- 1/4 x 1 1/2 Lg. - (Brass)	
25				1	TEE -- 1/4 Std. - - (Brass)	
26				2	NIPPLE -- 1/4 x 1 1/2 Lg. - (Brass)	
27	C-9053		C-9053-P 1/4	1	DRAIN COCK	
28			S-2809	1	CLAMP - Pipe to Centerframe	
29				1	MACHINE SCREW--1/4-20 x 1/2 Lg.-Rnd.Hd.-(St.)	
30						
31						
32					--- Water Inlet Man. to Air Comp. Cyl. ---	
33				1	CLOSE NIPPLE -- 3/8 Std. - (Brass)	
34	2C159		2C159-P 3/8	1	UNION	
35				1	PIPE -- 3/8 x 18 Lg. (Thr'd. 2 Ends) - (Brass)	
36						
37					--- Air Comp. to Ex. Man. Water Outlet ---	
38				2	NIPPLE -- 3/8 x 3 Lg. - (Brass)	
39	2C159		2C159-P 3/8	2	UNION	
40				1	PIPE--3/8 x 16 3/4 Lg. (Thr'd. 2 Ends) - (Brass)	
41						
42						
43						
44						
45						
46						
47						
48						
49						
50						

FOR OFF. HAND SEE

FOR OFF. NOT. SEE

FORM NO. 2-1

NAME WATER PIPING GROUP

ORIGINALLY ISSUED FOR 4 CYL. 9 x 12 MARINE

FOR TOTAL REQUIREMENTS PER ENGINE MULTIPLY NO. PARTS GIVEN ABOVE BY NO. REQ'D FOR THIS GROUP GIVEN ON INDEX SHEET

PARTS LIST

ATLAS IMPERIAL DIESEL ENGINE CO.
 OAKLAND, CALIF. MATTOON, ILL.

L-9915

ATLAS IMPERIAL DIESEL ENGINE CO. SUB-ASSEMBLY LIST

WHEN ORDERING PARTS ALWAYS GIVE ENGINE NUMBER-PART NUMBER-NAME-OR COMPLETE DESCRIPTION AND SIZE.
DO NOT ORDER PARTS BY REFERENCE NUMBERS
*INDICATES PARTS NOT SOLD INDIVIDUALLY

REF No.	PART NUMBER	No. USED	DESCRIPTION		REF No.	PART NUMBER	No. USED	DESCRIPTION	
	X68		GREASE CUP ASSEM. - BALL CHUCK	Includes		G264-A-LH		ROD ASSEM. - BILGE PUMP CONNECTING	Includes
1	C-1256	1	BODY				1	ROD	
2	C-1256	1	SPRING		1	264A-E	1	BUSHING	
3		1	BRONZE BALL -- 3/8" Dia.				5	ESCUTCHEON PIN -- #10 x 1 1/4 Lg.	
4	C-1264	1	GREASE CUP						
	X71		FILTER ASSEM. - HIGH PRESS. FUEL	Includes		G264-E		ROD ASSEM. - BILGE PUMP CONNECTING	Includes
1	F-1982	1	BODY				1	ROD	
2	S-1686	1	CAP - Filter Body		1	264A-E	1	BUSHING	
3	FO 25	1	ELEMENT - Filter				5	ESCUTCHEON PIN -- #10 x 1 1/4 Lg.	
	X204		VALVE ASSEM. - COMPRESSION RELIEF SAFETY	Includes		G264-E-LH		ROD ASSEM. - BILGE PUMP CONNECTING	Includes
1	F-2798	1	BODY - Valve				1	ROD	
2	3541	1	STEM ASSEM.		1	264A-E	1	BUSHING	
3	S-3339	1	SPRING				5	ESCUTCHEON PIN -- #10 x 1 1/4 Lg.	
4	S-3337	2	WASHER						
5	S-3335	1	CAP - Valve Body						
6		1	SETScrew--1/4-20 x 1 Lg.--Headless - Cup Pt.						
7		1	HALF NUT -- 1/4-20--Hex.						
	X215		CLAMP ASSEM. - SPRAY VALVE TEST	Includes		X265		WEIGHT ASSEM. - GOVERNOR	Includes
			Test Clamp & Cap (No Service Parts)				1	WEIGHT	
					1	C-544	1	ROLLER	
					2	S-2599	1	PIN - Roller	
	X228		SPRING ASSEM-FUEL SPRAY VALVE PUSH-ROD BUFFER	Includes		X266		QUILL ASSEM. - GOVERNOR THRUST	Includes
			Cage, Spring & Sleeve (No Service Parts)				1	QUILL	
					1	C-545	1	PLATE - Thrust	
	X237		PUSH-ROD ASSEM. - SPRAY VALVE	Includes		X270		WEIGHT ASSEM. - GOVERNOR	Includes
			Push-Rod Tube & Upper & Lower Plugs (No Service Parts)				1	WEIGHT	
					1	C-544	1	ROLLER	
					2	S-2599	1	PIN - Roller	
	X248		GEAR ASSEM. - CAMSHAFT	Includes		X271		BODY ASSEM. - GOVERNOR	Includes
			Gear Hub & Ring (No Service Parts)				1	BODY	
					1	S-806	1	PINION	
					2		1	WOODRUFF KEY -- 1/8 x 5/8 Std.	
					3	1110-2804	1	COLLAR - Retainer	
					4		2	TAPER PIN -- #8 x 2 1/4 Lg.	
	GA260-A		BODY ASSEM. - BILGE PUMP (2 1/2")	Includes		G306-C3		GEAR ASSEM. - REVERSE GEAR (LONG)	Includes
			1 BODY				1	GEAR	
1	373A-J	2	STUD - Packing Gland		1		2	BUSHING -- Bunting #H1449	
		1	PIPE PLUG -- 1 Std.						
	GA260-A-LH		BODY ASSEM. - BILGE PUMP (2 1/2")	Includes		G306-C4		GEAR ASSEM. - REVERSE GEAR (LONG)	Includes
			1 BODY				1	GEAR	
1	373A-J	2	STUD - Packing Gland		1		2	BUSHING - Bunting #H1452	
		1	PIPE PLUG -- 1 Std.						
	GA260-E		BODY ASSEM. - BILGE PUMP (3")	Includes		G307-C3		GEAR ASSEM. - REVERSE GEAR (SHORT)	Includes
			1 BODY				1	GEAR	
1	373A-J	2	STUD - Packing Gland		1	324-23	1	BUSHING	
		1	PIPE PLUG -- 1 Std.						
	GA260-E-LH		BODY ASSEM. - 3" BILGE PUMP	Includes		G307-C4		GEAR ASSEM. - REVERSE GEAR (SHORT)	Includes
			1 BODY				1	GEAR	
1	373A-J	2	STUD - Packing Gland		1	324-04	1	BUSHING	
		1	PIPE PLUG -- 1 Std.						
	G261-A		PLUNGER ASSEM. - BILGE PUMP (2 1/2")	Includes		G312-C3		COLLAR ASSEM. - CROWDER ADJUSTING	Includes
			Plunger & 1 1/4 Std. Pipe Plug (No Service Parts)				2	COLLAR	
					1	C-965814 1/4	2	BOLT	
							2	NUT -- 3/4-10--Hex.	
							2	HALF NUT -- 3/4-10--Hex.	
	G261-E		PLUNGER ASSEM. - BILGE PUMP (3")	Includes		G331-C3		COLLAR ASSEM. - SHIFTER	Includes
			Plunger & 1 1/4 Std. Pipe Plug (No Service Parts)				2	COLLAR	
					1	C-7936	2	CAPSCREW	
							2	NUT -- 5/8-11--Hex.	
							2	LOCKWASHER -- 5/8 SAE Reg.	
	X261		VALVE ASSEM. - FUEL SPRAY	Includes		G342-C4		SHOE ASSEM.-REVERSE GEAR DROM BRAKE(21)	Includes
1	861-E	1	BODY				1	SHOE	
2	S-2737	1	GLAND - Packing (Lower)		1	C-8439	1	LINING	
3	866-E	1	GLAND - Packing (Upper)		2		24	RIVET -- 3/16 x 7/8 Lg.--(Tubular)	
4		6	PACKING RING -- 1/4 I.D. x 1/8 O.D. x 1/4 Th. -- Garlock #333		3	C-1737	1	STUD - Brake Shoe Centering	
5	846-E	1	NUT - Gland						
6	866-D-E	1	SPINDLE ASSEM.						
7	856-E	1	NUT - Valve Seat						
8	853-E	1	CASING - Valve Spring						
9		1	MACHINE SCREW--1/4-20 x 1/2 Lg.--Rhd. Hd.						
10	850-E	1	SPRING						
11	857-A23	1	RETAINER - Spring						
12	8677	1	BALL BEARING -- Thrust						
13	876-E	1	NUT - Spindle						
14		1	NUT -- 1/2-13--Hex.						
	G264-A		ROD ASSEM. - BILGE PUMP CONNECTING	Includes					
			1 ROD						
1	264A-E	1	BUSHING						
		5	ESCUTCHEON PIN -- #10 x 1 1/4 Lg.						

ATLAS IMPERIAL SUB-ASSEMBLY LIST

WHEN ORDERING PARTS ALWAYS GIVE ENGINE NUMBER - PART NUMBER - NAME - OR COMPLETE DESCRIPTION AND SIZE.
DO NOT ORDER PARTS BY REFERENCE NUMBERS
*INDICATES PARTS NOT SOLD INDIVIDUALLY

REF. No.	PART NUMBER	QTY. USED	DESCRIPTION	
	G342-E3		SHOE ASSEM.-REVERSE GEAR DRUM BRAKE (10") Includes	
*		1	SHOE	
1	C-7846	1	LINING	
2		20	NUT -- 3/16 Dia. x 3/4 Lg.-(Tubular)	
3	C-1737	1	STUD - Brake Shoe Centering	
	X368		SILENCER ASSEM. - AIR SUCTION Includes	
1	F-2206	1	SILENCER	
2	F-2207	1	COVER	
3	C-5136	4	SPACER	
		4	CAPSCREW -- 3/8-16-NC x 1 1/2 Lg.	
		4	NUT -- 3/8-16-NC-Hex.	
		1	CAPSCREW -- 1/2-13-NC x 3 3/4 Lg.	
		1	NUT -- 1/2-13-NC-Hex.	
	G370-E1		PUMP ASSEM. - 1 1/4" CENTRIFUGAL Includes	
1	G370-E1	1	BODY ASSEM.	
2	371-E	1	COVER - Section	
3	3710-B	1	GASKET - Cover	
		12	MACHINE SCREW--1/4-20 x 3/8 Lg.-Rhd. Hd.	
4	G372-E1	1	IMPELLER & SHAFT ASSEM.	
5		1	PACKING -- 3/8 Sq. x 12 Lg. - (Flax)	
6	373-B	1	GLAND - Packing	
		4	NUT -- 7/16-14-Hex.	
7	X80	1	CUP ASSEM. - Grease	
8	361-PB4	1	BEARING - Steady	
		2	CAPSCREW -- 3/8-16 x 3/4 Lg.	
		2	CAPSCREW -- 3/8-16 x 1 Lg.	
		1	CAPSCREW -- 1/2-13 x 2 Lg.	
		1	WASHER - Ball Bearing	
9	366-PB41	1	BALL BEARING	
10	C-9029-P	1	ADAPTOR - Ball Bearing	
11	C-9070-P	1	RETAINER - Ball Bearing	
12	306A-PB41	1	ORANGE CUP -- 1/8 - Lunkenheimer -"Guard #00"	
13		1	FLANGE - Suction Pipe	
14	765-B	1	GASKET - Flange	
15	S-2334	2	CAPSCREW -- 1/2-13 x 1 Lg.	
		1	FLANGE - Pump Discharge	
16	765-B	1	GASKET - Flange	
17	S-2334	2	CAPSCREW -- 1/2-13 x 1 Lg.	
	GA370-E1		BODY ASSEM. - 1 1/4" CENTRIFUGAL PUMP Includes	
*		1	BODY	
1	374-E	1	BUSHING	
2	372A-E	2	STUD - Packing Gland	
		2	PIPE PLUG -- 3/8 Std.	
		1	PIPE PLUG -- 1/4 Std.	
	G372-E1		IMPELLER & SHAFT ASSEM.-CENTRIFUGAL PUMP -Includes	
*		1	IMPELLER	
1	372-E1	1	SHAFT	
2	C-821	1	PIN - Impeller Lock	
	X378		CYLINDER ASSEM. - PLYWOOD AIR BRAKE Includes	
*		1	CYLINDER	
1	5079	1	LINER	
	G384-28		COUPLING ASSEM. - COMPRESSION (3/4") Includes	
1	364-28	1	SLEEVE	
2	364A-28	2	COLLAR	
3	364B-28	2	NUT	
	X489		LIFTER ASSEM. - FUEL SPRAY VALVE Includes	
*		1	LIFTER	
1	866-E	1	ROLLER	
2	S-3032	1	PIN - Roller	
3	S-2447	1	PIN - Fuel Wedge	
4	C-3292	1	WASHER - Lifter Spring	
5	S-2265	1	PIN - Lifter Guide	
	X490		SPRING ASSEM.-FUEL SPRAY VALVE BUFFER Includes	
			Spring Cage, Spacer, Buffer Spring & Retainer	
			Plug (No Service Parts)	
	GA500-R		HEAD ASSEM. - CYLINDER Includes	
1	822	1	HEAD ASSEM.	
2	F-5275	1	VALVE - Inlet	
3	F-5276	1	VALVE - Exhaust	
4	513-R	2	SPRING - Valve	
5	514A-FXC4	2	WASHER - Valve Spring (Bottom)	
6	514-FXC4	2	WASHER - Valve Spring (Top)	
7		4	HALF NUT -- 5/8-11-Hex.	
8		2	LOCKWASHER -- Shakeproof - Type 11 - 5/8	
9	560-R	1	VALVE - Air Starting	
10	565-R	1	BUSHING - Air Start. Valve	
11	C-2151L1 1/4	2	RING - Piston	
12	579-R	1	BUSHING - Spring	
13	582-E	1	SPRING - Air Start. Valve	
14	580-E	1	WASHER - Spring (Bottom)	
15	583-FXC4	1	WASHER - Spring (Top)	
16		1	NUT -- 5/8-18-Hex.	

REF. No.	PART NUMBER	QTY. USED	DESCRIPTION	
	X511		VENT ASSEM. - FUEL OIL DAY TANK Includes	
*		1	BODY - Fuel Day Tank Vent	
1		1	TUBE -- 1/4 O.D. x 3 Lg. (Cop.)	
	G520-E32		ROCKER ASSEM. - VALVE Includes	
*		1	ROCKER	
1	550A-E2	2	BUSHING	
2	523-E	1	ROLLER	
3	524-E	1	PIN - Roller	
4	5527A-E	1	BALL CHECK ASSEM.	
	G520-R3		ROCKER ASSEM. - VALVE Includes	
*		1	ROCKER	
1	550A-E3	2	BUSHING	
2	523-E	1	ROLLER	
3	524-E	1	PIN - Roller	
4	5527A-E	1	BALL CHECK ASSEM.	
	G527A-E		BALL CHECK ASSEMBLY Includes	
			Body, Spring & Ball (No Service Parts)	
	X541		STEM ASSEM.-COMPRESSION RELIEF SAFETY VALVE Includes	
			Safety Valve & Valve Stem (No Service Parts)	
	G550-E32		ROCKER ASSEM. - VALVE Includes	
*		1	ROCKER	
1	550A-E2	2	BUSHING	
2	523-E	1	ROLLER	
3	524-E	1	PIN - Roller	
4	5527A-E	1	BALL CHECK ASSEM.	
	G550-R3		ROCKER ASSEM. - VALVE Includes	
*		1	ROCKER	
1	550A-E3	2	BUSHING	
2	523-E	1	ROLLER	
3	524-E	1	PIN - Roller	
4	5527A-E	1	BALL CHECK ASSEM.	
	G570-C31		HANDLE ASSEM. - AIR STARTING Includes	
1	570-C31	1	HANDLE	
		1	CAPSCREW -- 3/8-16 x 1 1/2 Lg.	
2	571-C3	1	PAWL ASSEMBLY	
3	572-030	1	SPRING	
4	571A-C3	1	SCREW	
		1	HALF NUT -- 5/16-18-Hex.	
	G571-C3		PAWL ASSEM. - AIR STARTING HANDLE Includes	
*		1	PAWL	
1	S-2892	1	PIN	
	G590-E32		ROCKER ASSEM. - AIR STARTING VALVE Includes	
*		1	ROCKER	
1	590A-E32	2	BUSHING	
2	523-E	1	ROLLER	
3	524-E	1	PIN - Roller	
4	5527A-E	1	BALL CHECK ASSEM.	
	G590-R3		ROCKER ASSEM. - AIR STARTING VALVE Includes	
*		1	ROCKER	
1	590A-R3	2	BUSHING	
2	523-E	1	ROLLER - Rocker	
3	524-E	1	PIN - Roller	
4	5527A-E	1	BALL CHECK ASSEM.	
	G594-E		LIFTER ASSEM. - AIR STARTING VALVE Includes	
*		1	LIFTER	
1	596-E	1	ROLLER	
2	596-E	1	PIN	

ATLAS IMPERIAL DIESEL ENGINE CO. SUB-ASSEMBLY LIST

WHEN ORDERING PARTS ALWAYS GIVE ENGINE NUMBER-PART NUMBER-NAME-OR COMPLETE DESCRIPTION AND SIZE.
DO NOT ORDER PARTS BY REFERENCE NUMBERS
*INDICATES PARTS NOT SOLD INDIVIDUALLY

ENGINE SIZE
7 1/2 x 10 1/2 - 9 x 12
 ASSEMBLY NO.
AL 173

REF. No.	PART NUMBER	No. USED	DESCRIPTION	
	G600-FB42		CYLINDER ASSEMBLY - (LINER TYPE)	Includes
1	C-5219	1	CYLINDER	
2	610-8B3	6	STUD - Cyl. Head	
3	6201-FB41	1	PIPE - Water Cyl. to Head Water	
4	C-3528	1	LINER ASSEM. - Cylinder	
5	604-FB4	2	GASKET - Liner	
6	605-N	2	GROMMET - Liner	
7	606A-N	2	COVER - Cylinder Clean-out	
8	C-264	2	GASKET - Cyl. Clean-out Cover	
9	610A-8B3	2	CAPSCREW -- 1/2-13 x 1 1/4 Lg.	
10	S-2914	2	NIPPLE - Cyl. Lube Oil	
11	612-E	2	GROMMET - Oil Nipple	
			WASHER - Grommet	
			GLAND - Packing	
	G600-R		CYLINDER ASSEMBLY	Includes
1	S-2263	1	CYLINDER	
2	605-N	4	PIPE PLUG -- 1 1/4 Std.	
3	606A-N	6	STUD - Cyl. Head	
4	C-264	1	COVER - Clean-out	
5	610A-8B3	1	GASKET - Cover	
6	612-R	4	CAPSCREW -- 1/2-13 x 1 1/4 Lg.	
7	S-2914	2	NIPPLE - Lube Oil	
8	610A-8B3	2	GLAND - Packing	
9	S-2914	2	GROMMET	
10	610-8B3	4	WASHER	
	G600-RB32		CYLINDER ASSEMBLY	Includes
1	S-2263	1	CYLINDER	
2	605-N	5	PIPE PLUG -- 1 1/4 Std.	
3	606A-N	6	STUD - Cylinder Head	
4	C-264	1	COVER - Clean-out	
5	610A-8B3	1	GASKET - Cover	
6	612-E	4	CAPSCREW -- 1/2-13 x 1 1/4 Lg.	
7	S-2914	2	NIPPLE - Lube Oil	
8	610A-8B3	2	GLAND - Packing	
9	S-2914	2	GROMMET	
10	610-8B3	4	WASHER	
	G601-FB41		LINER ASSEM. - CYLINDER	Includes
1	621A-F	1	LINER	
	G621-F		PIN ASSEM. - PISTON	Includes
1	621A-F	1	PIN	
	G621-R1		PIN ASSEM. - PISTON	Includes
1	621A-F	1	PIN	
	G621-RB32		PIN ASSEM. - PISTON	Includes
1	621A-F	1	PIN	
	GA630-FB4		ROD ASSEM. - CONNECTING	Includes
1	P-691	1	ROD	
2		1	BUSHING	
	GA630-R3		ROD ASSEM. - CONNECTING	Includes
1	P-690	1	ROD	
2		1	BUSHING	
	G632-E		VALVE ASSEM. - BALL CHECK	Includes
			Valve Body, Steel Ball & Retainer Pin (No Service Parts)	
	GA636-E31		BEARING ASSEM. - CONNECTING ROD	Includes
1	636A-E31-A	2	BEARING	
2	636A-E31-B	2	SHIM - (.1/16)	
3	636A-E31-C	2	SHIM - (.1/32)	
4	636A-E31-D	4	SHIM - (.010)	
5	636A-E31-E	6	SHIM - (.003)	
6	C-250611 1/2	2	CAPSCREW	
7		2	CASTLE NUT -- 3/8-24-Box.	
8	C-7972L 3/4	2	COTTER PIN -- 3/32 x 1 Lg.	
			PIN - Bolt Retainer	

REF. No.	PART NUMBER	No. USED	DESCRIPTION	
	G680-C		BEARING ASSEM. - CAMSHAFT	Includes
1	680-C	1	BEARING	
	G683-C4		BEARING ASSEM. - CAMSHAFT	Includes
1	C-308	1	BEARING	
	X699		SILENCER ASSEM. - AIR SUCTION	Includes
1	P-2187	1	SILENCER	
2	P-2188	1	COVER	
	X704		ROCKER ASSEM. - VALVE	Includes
1	550A-P2	1	ROCKER	
2	523-E	2	BUSHING	
3	524-E	1	ROLLER	
4	527A-E	1	PIN - Roller	
	X706		ROCKER ASSEM. - VALVE	Includes
1	550A-P2	1	ROCKER	
2	523-E	2	BUSHING	
3	524-E	1	ROLLER	
4	527A-E	1	PIN - Roller	
	X708		ROCKER ASSEM. - AIR STARTING	Includes
1	550A-E32	1	ROCKER	
2	523-E	2	BUSHING	
3	524-E	1	ROLLER	
4	527A-E	1	PIN - Roller	
	X720		HEAD ASSEM. - H.P. FUEL PUMP	Includes
1	2C1832L 1/8	1	HEAD	
	X731		HEAD ASSEM. - H.P. FUEL PUMP	Includes
1	2C1832L 1/8	1	HEAD	
	X781		MANIFOLD ASSEM. - SPRAY VALVE DRAIN	Includes
			Pipe & Tees (No Service Parts)	
	X794		CONTROL ASSEM. - GOVERNOR SPEED	Includes
1	C-1668	1	HANDWHEEL	
2	C-3797	1	SLEEVE - Adjusting	
3		1	MACHINE SCREW--1/4-20 x 1/2 Lg.-Flat Hd.	
	G796-E		FITTING ASSEM.-H.P. FUEL PUMP DISCHARGE	Includes
1	T96-E32	1	FITTING	
2	T96A-E	2	RING	
3	T97-E33	1	NUT	
	G796-E32		FITTING ASSEM.-H.P. FUEL PUMP DISCHARGE	Includes
1	G796-E	1	FITTING ASSEM.	
2	T960-E1	1	VALVE - Check	
3	T960-E2	1	SPRING - Check Valve	
	X822		HEAD ASSEM. - CYLINDER	Includes
1	612-8B1	1	HEAD	
2	634A-E	6	PIPE PLUG -- 3/4 Std.	
3	527-E	6	PIPE PLUG -- 1 Std.	
4	T64-E	2	GUIDE - In. & Exh. Valve	
			STUD - Spray Valve Clamp	
			STUD - Rocker Shaft Bearing	
			STUD - Exhaust Elbow	

1950E ASSEMBLY NO. AL 174
 ENGINE SIZE 7 1/2 x 10 1/2 - 9 1/2

ATLAS IMPERIAL DIESEL ENGINE CO. SUB-ASSEMBLY LIST

WHEN ORDERING PARTS ALWAYS GIVE ENGINE NUMBER - PART NUMBER - NAME - OR COMPLETE DESCRIPTION AND SIZE.
 DO NOT ORDER PARTS BY REFERENCE NUMBERS
 *INDICATES PARTS NOT SOLD INDIVIDUALLY

REF. No.	PART NUMBER	No. USED	DESCRIPTION		REF. No.	PART NUMBER	No. USED	DESCRIPTION	
	6823-RB3		ROD ASSEM. - H.P. PUMP CONNECTING	Includes		6929-C3		ROD ASSEM. - AIR COMPRESSOR CONNECTING	Includes
*		1	ROD		*		1	ROD	
*		1	CAP		1	232-455	1	BUSHING	
1	C-227-D	4	SHIM - (.010)			X929		BEARING ASSEM. - FUEL WEDGE SHAFT	Includes
1	C-227-E	4	SHIM - (.005)		*		1	BEARING	
2	C-222	2	BOLT		1	8-961	1	BUSHING	
3		2	CASTLE NUT -- 5/8-16-Hex.			X1074		SEAL ASSEM. - CRANKSHAFT OIL	Includes
		2	COTTER PIN -- 1/8 x 1 Lg.		*		2	SEAL	
					1	C-4537	2	OASSET	
							2	CAPSCREW -- 3/8-16 x 1 1/2 Lg.	
							2	NUT -- 3/8-16-Hex.	
							2	LOCKWASHER -- 3/8 S&S Reg.	
	6847-FB4		DOOR ASSEM. - FUEL PUMP HOUSING	Includes		X1079		CORE ASSEM. - LUBE OIL COOLER	Includes
1	947-FB4	1	DOOR - Fuel Pump Housing					Pipe, Pipe Plugs & Wire (No Service Parts)	
2	0947A-FB4	1	LATCH ASSEM. - Door			X1080		COOLER ASSEM. - LUBE OIL	Includes
3		1	WING NUT -- 1/2-13 Std.		1	F-4290	1	PIPE (Outer)	
4		1	TAPER PIN -- #2 x 1 3/4 Lg.		2	X1079	1	CORE ASSEM.	
					3	C-3682	2	FLUG - Retainer	
							2	MACHINE SCREW--1/4-20 x 3/4 Lg.-Std. Hd.	
	6847A-FB4		LATCH ASSEM. - FUEL PUMP HOUSING DOOR	Includes		X1105		MANIFOLD ASSEM. - EXHAUST	Includes
*		1	LATCH		*		1	MANIFOLD - Exhaust	
1	S-2247	1	STUD		1	754-E	4	PIPE PLUG -- 1 1/4 Std.	
							0	STUD	
					1	C-2010L2 1/2	4	STUD (Std)	
	6847B-RB3		DOOR ASSEM. - FUEL PUMP HOUSING	Includes		X1110		PUMP ASSEM. - 2 1/2" BILGE	Includes
1	947-RB3	1	DOOR		1	04260-A	1	BODY ASSEM.	
2	0947A-RB3	1	LATCH ASSEM.		2	0261-A	1	PLUNGER ASSEM.	
3		1	WING NUT -- 1/2-13 Std.		3	262-A	1	GLAND - Packing	
4		1	TAPER PIN -- #2 x 1 3/4 Lg.		4		1	PACKING -- 1/8 Sq. x 43 Lg.-(Flex)	
							4	NUT -- 1/2-13-Hex.	
	6847C-RB3		HINGE ASSEM. - FUEL PUMP HOUSING DOOR	Includes		X1111		PUMP ASSEM. - 2 1/2" BILGE	Includes
			Door Hinges (No Service Parts)		1	GAD20-A-LX	1	PUMP ASSEM.	
					2	0261-A	1	PLUNGER ASSEM.	
					3	262-A	1	GLAND - Packing	
					4		1	PACKING -- 1/8 Sq. x 43 Lg. - (Flex)	
							4	NUT -- 1/2-13-Hex.	
	6850-E		SPINDLE ASSEM. - SPRAY VALVE	Includes		G1197-E1		VALVE ASSEM.-COMPRESSION RELEASE(SNIFFER)	Includes
			Spindle & Extension (No Service Parts)		1	1197-E1	1	BODY	
					2	G1198-E	1	STEM ASSEM.	
	6870-R31		ROCKER ASSEM. - SPRAY VALVE	Includes		G1198-E		STEM ASSEM.-COMPRESSION RELEASE VALVE(SNIFFER)	Includes
*		1	ROCKER					Valve Stem & Handle (No Service Parts)	
1	0527A-E	1	BALL CHECK ASSEM.			G1200-R3		RAIL ASSEM. - FUEL	Includes
					*		1	TUBE - Fuel	
					1	1200-E1	4	BODY - Isolating Valve	
					2	1200-E	4	SEAT - Isolating Valve	
					3	1200-E	4	FLUG - Isolating Valve	
					4	1200-C31	4	STEM - Isolating Valve	
					5	866-E	4	GLAND - Packing	
					6	1200-C3	4	NUT - Gland	
					7		12	RING - Packing -- 1/4 I.D. x 1/2 O.D. x 1/4 Th. - Garlock #333	
	6870-RB3		ROCKER ASSEM. - SPRAY VALVE	Includes		G1200-R4		RAIL ASSEM. - FUEL	Includes
1	527-RB3	1	ROCKER		*		1	TUBE - Fuel	
			BALL		1	1200-E1	5	BODY - Isolating Valve	
					2	1200-E	5	SEAT - Isolating Valve	
					3	1200-E	5	FLUG - Isolating Valve	
					4	1200-C31	5	STEM - Isolating Valve	
					5	866-E	5	GLAND - Packing	
					6	1200-C3	5	NUT - Gland	
					7		12	PACKING RING -- 1/4 I.D. x 1/2 O.D. x 1/4 Th. - Garlock #333	
	6901-C31		HEAD ASSEM.-4" AIR COMPRESSOR CYLINDER	Includes					
1	04901-C31	1	HEAD ASSEM.						
2	905-C3	1	VALVE - Inlet						
3	908-C3	1	SPRING - Valve						
4	908B-AE3	1	WASHER - Spring Retainer						
5	908A-C3	1	NUT - Inlet Valve						
		1	NUT -- 5/16-18-Hex.						
8	916-C4	1	VALVE - Discharge						
9	920-C4	1	GUIDE - Discharge Valve						
10	924-C4	1	COLLAR - Discharge Valve						
11	919-C4	1	SPRING - Discharge Valve						
12	923-C41	1	CAP - Discharge Valve Guide						
13	918-E3	1	FLANGE - Discharge Valve Retainer						
14	918D-E3	1	GASKET - Flange to Head						
		2	NUT -- 1/2-13-Hex.						
17	915A-C3	1	SCREW - Valve Guide Cap Retainer						
18	922D-C4	1	NUT ASSEM. - Valve Guide Retainer Screw						
19	922C-C3	1	GASKET - Nut to Flange						
20	922A-C3	1	HANDLE - Quot. Valve Unloader						
		2	HALF NUT -- 3/8-16-Hex.						
	GA901-C31		HEAD ASSEM. - 4" AIR COMPRESSOR CYLINDER	Includes					
*		1	HEAD						
1	907-C3	1	GUIDE - Inlet Valve						
2	C-200BL2	2	STUD - Disch. Valve Retainer Flange						
		2	PIPE PLUG -- 1/2 Std.						
		2	PIPE PLUG -- 1/2 Std. - C't's'k. Hd.						
		1	PIPE PLUG -- 1 Std. - C't's'k. Hd.						
		1	REDUCING BUSHING -- 1/2 x 3/8 Std.						
	G922-C4		NUT ASSEM.-VALVE GUIDE RETAINER SCREW	Includes					
*		1	NUT						
1	918B-C3	1	STUD						

ATLAS IMPERIAL SUB-ASSEMBLY LIST

DIESEL ENGINE CO.

WHEN ORDERING PARTS ALWAYS GIVE ENGINE NUMBER-PART NUMBER-NAME-OR COMPLETE DESCRIPTION AND SIZE.
DO NOT ORDER PARTS BY REFERENCE NUMBERS
*INDICATES PARTS NOT SOLD INDIVIDUALLY

ISSUE ASSEMBLY NO. AL 175
7/12/50-9/12/50

REF. No.	PART NUMBER	No. USED	DESCRIPTION	
	G1203-AX3		CLAMP ASSEM. - FUEL RAIL Clamp & Cap (No Service Parts)	Includes
	G1203-E		CLAMP ASSEM. - FUEL RAIL Clamp & Cap (No Service Parts)	Includes
	X1211		LIFTER ASSEM. - INLET OR EXHAUST VALVE	Includes
1	530-E	1	LIFTER	
2	531-E	1	ROLLER	
			1 PIN	
	G1215-E		VALVE ASSEM. - FUEL OIL ACCUMULATOR	Includes
1	1208-031	1	BODY	
2		1	STEM - Valve	
3		3	PACKING -- 1/2 O.D. x 1/4 I.D. x 1/4 Wide Darlack #333	
3	866-E	1	GLAND - Packing	
4	1208-03	1	NUT - Packing Gland	
	X1229		PUMP ASSEM. - 3" BILGE	Includes
1	04200-E	1	BODY ASSEM.	
2	0201-E	1	FLYWHEEL ASSEM.	
3	862-E	1	GLAND - Packing	
4		1	PACKING -- 1/2 Sq. x 33 Lg.-(Flex)	
			4 NUT -- 1/2-13-Hex.	
	G1230-E 1		VALVE ASSEM. - FUEL PRESSURE REGULATING	Includes
1	01243-E	1	HANDLE ASSEM.	
2	1830A-E	1	FIN - Handle to Bearing	
			2 COTTER PIN -- 3/32 x 3/4 Lg.	
4	1844-E	1	SECTOR	
			2 CAPSCREW -- 5/16-18 x 1 1/4 Lg.	
			2 NUT -- 5/16-18-Hex.	
7	1236-E	1	BEARING - Handle	
8	1237-E1	1	COIL - Spring	
9	1245-E1	1	PLUG - (Upper)	
10	1238-E	1	SPRING - Regulat. Valve	
11	1240-E	1	NUT - Spring Adjust. Screw	
			MACHINE SCREW--1/4-20 x 1/2 Lg.-Std. Hd.	
13	1239-E	1	SCREW - Spring Adjusting	
14	1233-E	1	STEM - Valve Stem	
15	1234-E	1	SEAT - Valve Stem	
16	1230-E1	1	BODY - Regulat. Valve	
17		3	PACKING RING--13/16 O.D. x 1/2 I.D. x 3/16 Wide - Darlock #333	
18	1231a-E	1	RING - Packing Retainer	
19	1231-E2	1	GLAND - Packing	
20	1232-E1	1	STUD - Septum	
21		1	HALF NUT -- 1-5-Hex.	
22	1242-E	1	ELBOW - Inlet	
23	1237A-E	1	CUP - Drain	
	X1233		ECCENTRIC ASSEM. - AIR COMPRESSOR	Includes
1		1	ECCENTRIC	
1		1	CAP	
1	C-2266L 3/4	2	PIN - Dowel	
3	C-2108L 1/4	4	STUD	
			4 CASTLE NUT -- 1/2-20-Hex.	
			4 COTTER PIN -- 3/32 x 1 Lg.	
	X1235		SPROCKET ASSEM.-CENTRIFUGAL PUMP DRIVE	Includes
1		2	SPROCKET	
1	C-2108L 1/4	2	STUD	
2		2	CASTLE NUT -- 1/2-20-Hex.	
			2 COTTER PIN -- 3/32 x 1 Lg.	
	G1243-E		HANDLE ASSEM.-FUEL PRESS. REGULAT. VALVE	Includes
1	1243-E	1	CAM - Spring Control	
2	1117-E	1	EXTENSION - Handle	
3	1249-E	1	SCREW - Handle	
1	1118-E1	1	PAWL	
5	1124-E	1	SPRING - Pawl	
6	1126-E	1	SCREW - Spring Adjust.	
7		1	TAPER PIN -- #1 x 1 Lg.	
			1 HALF NUT -- 1/4-20-Hex.	
	G1275-E832		PUMP ASSEM. - PRIMING	Includes
1		1	BODY	
1		1	FLYWHEEL	
1		1	PACKING -- 1/8 Rd. x 7 Lg.-(Petrol)	
2	S-2055	1	WASHER - Packing	
3	S-2064	1	NUT	
			1 NUT -- 7/16-20-Hex.	

REF. No.	PART NUMBER	No. USED	DESCRIPTION	
	X1306		ROCKER ASSEM. - SPRAY VALVE	Includes
1	0027A-E	1	ROCKER	
			1 BALL CHECK ASSEM.	
	G1338-R831		PUMP ASSEM. - FUEL TRANSFER	Includes
1	1240-R83	1	BODY	
2		1	COVER - Pump Body	
3	1239B-R83	2	FIN - Cover to Body Dowel	
4		4	GASKET - Cover to Body	
4	01241-R83	1	MACHINE SCREW--1/4-20 x 3/4 Lg.-Fill. Hd.	
5	01242-R83	1	GEAR & SHAFT ASSEM. (Drive)	
6	1243-R83	1	GLAND - Packing	
7	1244-R83	1	NUT - Packing Gland Retainer	
8	1245-R83	1	DOCK-NUT - Packing Gland	
9		1	PACKING -- 3/16 Sq. x 13 Lg. - (Petrol)	
	G1341-R83		GEAR & SHAFT ASSEM.-FUEL TRANSFER PUMP(DRIVE)	Includes
			Gear & Shaft (No Service Parts)	
	X1341		PUSH-ROD ASSEM. - SPRAY VALVE	Includes
			Tube & Sockets (No Service Parts)	
	G1342-R83		GEAR & SHAFT ASSEM.-FUEL TRANSFER PUMP(DRIVEN)	Includes
			Gear & Shaft (No Service Parts)	
	X1470		SEAL ASSEM. - CRANKSHAFT OIL	Includes
1	C-6199	2	OIL SEAL	
		2	GASKET	
		2	CAPSCREW -- 3/8-16 x 1 1/8 Lg.	
		2	NUT -- 3/8-16-Hex.	
		2	LOCKWASHER -- 3/8 SAE Reg.	
	X1583		PIPE ASSEM. - AIR STARTING VALVE TO GLOBE VALVE	Includes
			Nipple & Pipe Coupling (No Service Parts)	
	X1607		HEAD ASSEM. - CYLINDER	Includes
1	512-R81	1	HEAD	
2	854A-E	6	PIPE PLUG -- 3/4 Std.	
3	507-E	3	PIPE PLUG -- 1 Std.	
4	764-E	2	GUIDE - In. & Exh. Valve	
		1	STUD - Spray Valve Clamp	
		4	STUD - Nocken Shaft Bearing	
		2	STUD - Exhaust Elbow	
	X1608		HEAD ASSEM. - CYLINDER	Includes
1	X1607	1	HEAD ASSEM.	
2	P-5275	1	VALVE - Inlet	
3	P-5276	1	VALVE - Exhaust	
4	515-E	2	SPRING - Valve	
5	514a-PX04	2	WASHER - Valve Spring (Bottom)	
6	514-PX04	2	WASHER - Valve Spring (Top)	
7		4	HALF NUT -- 5/8-11-Hex.	
8		2	LOCKWASHER -- 5/8 Shakeproof -- Type 11	
9	560-E	1	VALVE - Air Starting	
10	565-E	1	BUSHING - Valve	
11	C-2151L 1/4	2	RING - Piston	
12	578-E	1	BUSHING - Spring	
13	582-E	1	SPRING - Air Starting Valve	
14	588-E	1	WASHER - Spring (Bottom)	
15	583-PX04	1	WASHER - Spring (Top)	
16		1	NUT -- 5/8-11-Hex.	
	X1748		VALVE ASSEM. - SPRAY (DRAIN TYPE)	Includes
1	P-4983	1	BODY	
2	S-2757	1	GLAND - Packing (Lower)	
3	866-E	1	GLAND - Packing (Upper)	
4		6	PACKING RING -- 1/4 I.D. x 1/2 O.D. x 1/4 Th. Darlack #333	
5	865-E	1	NUT - Gland	
6	0550-E	1	SPINDLE ASSEM.	
7	854-E	1	NUT - Valve Seat	
8	853-E	1	CASING - Valve Spring	
		1	MACHINE SCREW--1/4-20 x 1/2 Lg. - Std. Hd.	
10	858-E	1	SPRING	
11	857-AX3	1	PLUG - Spring	
12	5077	1	BALL BEARING - Thrust	
13	878-E	1	NUT - Spindle	
14		1	NUT -- 1/2-13-Hex.	

ATLAS IMPERIAL DIESEL ENGINE CO. SUB-ASSEMBLY LIST

WHEN ORDERING PARTS ALWAYS GIVE ENGINE NUMBER - PART NUMBER - NAME - OR COMPLETE DESCRIPTION AND SIZE.
DO NOT ORDER PARTS BY REFERENCE NUMBERS
*INDICATES PARTS NOT SOLD INDIVIDUALLY

ASSEMBLY LIST NO. **AL 176**
 ENGINE SIZE **7 1/2 x 10 1/2 - 9 1/2**

REF. No.	PART NUMBER	No. USED	DESCRIPTION	
	X1749		BODY ASSEM. - GOVERNOR	Includes
1	X271	1	BODY ASSEM.	
2	X255	2	WEIGHT ASSEM.	
3	X21220	2	PIN - Weight	
4		4	CASTLE NUT -- 3/8-24-Hex.	
		4	COTTER PIN -- 3/32 x 3/4 Lg.	
5	X255	1	QUILL ASSEM.	
6	C-548	1	KEY - Thrust Quill	
7	X220	1	BALL BEARING - Thrust	
	X1759		CAMSHAFT ASSEMBLY	Includes
1	1353-FB4	1	CAMSHAFT & COUPLING	
2		1	GEAR - Rotary Pump Drive	
		3	CAPSCREW -- 3/8-16 x 3/4 Lg.	
	X1791		PUMP ASSEM. - 3" BILGE	Includes
1	0a260-E-LR	1	BODY ASSEM.	
2	0261-E	1	PLUNGER ASSEM.	
3	262-E	1	GLAND - Packing	
4		1	PACKING -- 1/8 Sq. x 33 Lg. - (Flax)	
		4	NUT -- 1/2-13-Hex.	
	X1809		DOOR ASSEM. - ROTARY PUMP	Includes
		1	DOOR	
		1	CAP - Pump Gear & Bearing	
1	C-5674	2	GASKET - Cap	
		4	CAPSCREW -- 1/2-13 x 3 3/4 Lg.	
		1	CAP - Pump Clamp	
		2	CAPSCREW -- 1/2-13 x 2 1/4 Lg.	
	X1810		BLOCK ASSEM. - GOVERNOR SPRING	Includes
1	P-5069	1	BLOCK	
2	C-543	1	PIN - Fork	
3	C-549	1	ROD - Spring	
4	C-4361	1	PIN - Spring Rod	
	X1814		SHAFT ASSEM. - PUMP DRIVE	Includes
1	1355-R23	1	SHAFT	
		1	SLEEVE	
	X1851		COVER ASSEM. - PUMP DRIVE SHAFT BEARING END	Includes
		1	COVER	
1		1	OIL SEAL -- Perfect #1501	
	X1855		DOOR ASSEM. - ROTARY PUMP	Includes
		1	DOOR	
		1	CAP - Pump Gear	
1	C-5674	2	GASKET - Cap	
		4	CAPSCREW -- 1/2-13 x 3 3/4 Lg.	
		1	CAP - Pump Clamp	
		2	CAPSCREW -- 1/2-13 x 2 1/4 Lg.	
	X1890		BEARING ASSEM. - CONNECTING ROD	Includes
		1	BEARING (Cap)	
		1	BEARING (Foot)	
1	C-7476-A	2	SHIM - (1/16)	
1	C-7476-B	2	SHIM - (1/32)	
1	C-7476-D	4	SHIM - (.010)	
1	C-7476-E	6	SHIM - (.008)	
2	C-2506LL 1/2	2	CAPSCREW	
3		2	CASTLE NUT -- 3/8-24-Hex.	
3		2	COTTER PIN -- 1/16 x 1 Lg.	
	X1935		CAMSHAFT ASSEMBLY	Includes
1	1353-FB4	1	CAMSHAFT AND COUPLING	
2		1	GEAR - Rotary Pump Drive	
		3	CAPSCREW -- 3/8-16 x 3/4 Lg.	
	X1957		COLUMN ASSEM. - JAHN'S GOVERNOR	Includes
1	S-1108	1	COLUMN	
		2	STUD - Regulator Bracket	
	X1958		DASH-POT ASSEM. - JAHN'S GOVERNOR	Includes
1	X1958	1	CYLINDER ASSEM.	
2	S-322	1	PISTON	
3	S-320	1	ROD-END	
4		1	MACHINE SCREW -- 1/4-20 x 5/8 Lg. - Flat Hd.	
5	S-322	1	ROD - Piston	
6	S-321	1	PIN - Rod-End	
7	S-345	1	COVER - Cylinder	
8		4	CLOSE WIPPLE -- 1/8 Std.	
9		1	ELBOW -- 1/8 Std.	
10	C-9847-P 1/8	1	ANGLE VALVE - Needle Point	
11		1	WRENCH -- 1/8 Std.	
	X1959		CYLINDER ASSEM. - JAHN'S GOV. DASH-POT	Includes
1	S-1108	1	CYLINDER	
		1	STUD	
	X1960		LOCK ASSEM. - JAHN'S GOV. REGULATOR DISC	Includes
			Lock & Lock Button (No Service Parts)	
	X1967		COVER ASSEM. - JAHN'S GOV. COLUMN UPPER BEARING	Includes
		1	COVER	
1		1	OIL SEAL -- National Motor Brg. Co. #10151	
	X1988		BODY ASSEM. - LUBE OIL PRESSURE PUMP	Includes
		1	BODY	
1	C-2106LL 1/8	4	STUD	
	X1989		GEAR & SHAFT ASSEM. - PRESS. PUMP (DRIVE)	Includes
1	C-6995	1	GEAR	
2	C-7588	1	SHAFT	
3		1	WOODRUFF KEY -- 1/8 x 3/4 Std.	
	X1990		GEAR & SHAFT ASSEM. - PRESS. PUMP (DRIVEN)	Includes
1	C-3024	1	GEAR	
2	C-7588	1	SHAFT	
	X1991		PUMP ASSEM. - LUBE OIL PRESSURE	Includes
1	X1990	1	BODY ASSEM.	
2	X1990	1	GEAR & SHAFT ASSEM. - (Drive)	
3	X1990	1	GEAR & SHAFT ASSEM. - (Driven)	
4	P-5155	1	COVER - Pump Body	
5	C-6883	1	GASKET - Cover to Body	
		4	NUT -- 3/8-24-Hex.	
6	C-7402	2	PIN - Pump Body Cover Dowel	
	X1994		HOUSING ASSEM. - GOVERNOR DRIVE	Includes
		1	HOUSING	
1	C-2010L2 1/4	4	STUD	
	X1995		HOUSING ASSEM. - JAHN'S GOV. DRIVE	Includes
		1	HOUSING	
1	C-2010L2 1/4	4	STUD	
	X2037		COVER ASSEM. - CLUTCH SHIFTER	Includes
		2	COVER	
1	C-2706L4	2	CAPSCREW	
2		2	CAPSCREW -- 1/2-13 x 5 Lg.	
		4	NUT -- 1/2-13-Hex.	
		4	LOCKWASHER -- 1/2 S&S Reg.	
	X2038		DRUM ASSEM. - REVERSE GEAR	Includes
		1	DRUM	
1	C-7529	1	BUSHING	
2		1	OIL SEAL -- National Motor Bearing Co. #65120	
	X2039		COVER ASSEM. - REVERSE GEAR DRUM	Includes
		1	COVER	
1	C-7530	1	BUSHING	
2		1	OIL SEAL -- National Motor Bearing Co. #65053	
	X2040		SHAFT ASSEM. - REVERSE GEAR PINION	Includes
		1	SHAFT	
1	S-2391	1	PIN	

ATLAS IMPERIAL DIESEL ENGINE CO. SUB-ASSEMBLY LIST

WHEN ORDERING PARTS ALWAYS GIVE ENGINE NUMBER - PART NUMBER - NAME - OR COMPLETE DESCRIPTION AND SIZE.
DO NOT ORDER PARTS BY REFERENCE NUMBERS
*INDICATES PARTS NOT SOLD INDIVIDUALLY

ASSEMBLY LIST NO. **AL-178**
 ENGINE SIZE **7 1/2 - 10 1/2 - 9 1/2**

REF. No.	PART NUMBER	No. USED	DESCRIPTION	
	X2102		MANIFOLD ASSEM. - AIR INLET Manifold & Flanges (No Service Parts)	Includes
	X2103		MANIFOLD ASSEM. - AIR INLET Manifold & Flanges (No Service Parts)	Includes
	X2104		CRANK ASSEM. - BILGE PUMP 1 DISC 1 PIN - Pump Drive 1 C-8011L 3/8 1 PIN - Conn. Rod Retainer Washer Lock	Includes
	X2113		ECCENTRIC ASSEM. - AIR COMPRESSOR 1 ECCENTRIC 1 CAP 1 S-2760 2 PIN - Dowel 2 C-2106L4 4 STUD - Cap 3 CASTLE NUT -- 1/2-20-Hex.	Includes
	X2137		SHAFT ASSEM. - THRUST 1 SHAFT 1 GEAR 1 C-301A-C4 2 CAPSCREW -- 1/2-13 x 1 1/2 Lg.	Includes
	X2149		BEARING ASSEM. - CHAIN IDLER SHAFT 1 BEARING 1 OIL SEAL -- National Motor Brg. Co. #50049	Includes
	X2233		MANIFOLD ASSEM. - LUBE OIL Pipe, Inlet & Outlet Tees (No Service Parts)	Includes
	X2234		MANIFOLD ASSEM. - LUBE OIL Pipe, Inlet & Outlet Tees (No Service Parts)	Includes
	X2235		CRANKSHAFT ASSEMBLY 1 CRANKSHAFT 1 GEAR 1 PIN - Gear Dowel 2 RING - Oil Thrower 1 PIN - Cent. Pump Drive Sprocket 1 PIPE PLUG -- 1/4 Std. - C't's'k. Hd.	Includes
	X2236		CRANKSHAFT ASSEMBLY 1 CRANKSHAFT 1 GEAR 1 PIN - Gear Dowel 2 RING - Oil Thrower 1 PIN - Cent. Pump Drive Sprocket 1 PIPE PLUG -- 1/4 Std. - C't's'k. Hd.	Includes
	X2238		SHAFT ASSEM. - REVERSE GEAR PINION 1 SHAFT 1 PIN 1 S-2891	Includes
	X2242		SPROCKET ASSEM.-CENTRIFUGAL PUMP DRIVE 2 SPROCKET 1 C-8285L 3/4 2 PIN - Dowel 2 C-2110L3 1/4 2 STUD 2 CASTLE NUT -- 5/8-18-Hex. 2 COTTER PIN -- 1/8 x 1 1/4 Lg.	Includes
	X2243		COVER ASSEM. - REVERSE GEAR DRUM 1 COVER 1 BUSHING 2 C-8366 1 OIL SEAL -- National Motor Brg. Co. #55109	Includes
	X2244		DRUM ASSEM. - REVERSE GEAR 1 DRUM 1 BUSHING 2 C-8366 1 OIL SEAL -- National Motor Brg. Co. #55129	Includes
	X2245		MANIFOLD ASSEM. - AIR STARTING 1 577-C4 4 ELBOW - Air Start. Man. 2 NIPPLE -- 1 1/4 x 5 1/2 Lg. 3 TEE -- 1 1/4 Std. 4 ELBOW -- 1 1/4 Std. 5 NIPPLE -- 1 1/4 x 14 Lg. 6 NIPPLE -- 1 1/4 x 8 1/2 Lg. 7 NIPPLE -- 1 1/4 x 4 1/2 Lg. 8 ELBOW -- 1 1/4 - 45° Std. 9 X1583 1 NIPPLE ASSEM. - Manifold to Globe Valve	Includes

REF. No.	PART NUMBER	No. USED	DESCRIPTION	
	X2256		CAMSHAFT ASSEMBLY 1 CAMSHAFT & COUPLING 1 1353-FB4 1 GEAR - Rotary Pump Drive 2 CAPSCREW -- 3/8-16 x 3/4 Lg.	Includes
	X2257		MANIFOLD ASSEM. - LUBE OIL Pipe & Tees (No Service Parts)	Includes
	X2266		ROD ASSEM. - BRAKE POST TIE 1 ROD 1 SUT -- 7/8-9-Hex.	Includes
	X2267		STRAP ASSEM.-AIR COMPRESSOR ECCENTRIC 1 STRAP (Upper) 1 STRAP (Lower) 1 C-4554-A 2 SHIM - (1/32) 1 C-4554-B 2 SHIM - (1/32) 1 C-4554-D 4 SHIM - (.010) 1 C-4554-E 8 SHIM - (.003) 2 BOLT 2 CASTLE NUT -- 3/4-16-Hex. 2 COTTER PIN -- 1/8 x 1 1/4 Lg.	Includes
	X2268		STRAP ASSEM. - AIR COMPRESSOR ECCENTRIC 1 STRAP (Upper) 1 STRAP (Lower) 1 C-6145-A 2 SHIM - (1/16) 1 C-6145-B 2 SHIM - (1/32) 1 C-6145-D 4 SHIM - (.010) 1 C-6145-E 8 SHIM - (.003) 2 BOLT 2 CASTLE NUT -- 3/4-16-Hex. 2 COTTER PIN -- 1/8 x 1 1/4 Lg.	Includes
	X2269		MANIFOLD ASSEM. - AIR INLET Manifold & Flanges (No Service Parts)	Includes
	X2270		SPROCKET ASSEM. - CENTRIFUGAL PUMP DRIVE -Includes 1 SPROCKET 1 C-2106L2 2 STUD 2 CASTLE NUT -- 1/2-20-Hex. 2 COTTER PIN -- 3/32 x 1 Lg.	Includes
	X2276		MANIFOLD ASSEM. - AIR INLET Manifold & Flanges (No Service Parts)	Includes
	X2277		MANIFOLD ASSEM. - LUBE OIL Pipe, Inlet & Outlet Tees (No Service Parts)	Includes
	X2278		MANIFOLD ASSEM. - LUBE OIL Pipe, Inlet & Outlet Tees (No Service Parts)	Includes
	X2280		CAMSHAFT ASSEMBLY 1 CAMSHAFT & COUPLING 1 1353-FB4 1 GEAR - Rotary Pump Drive 2 CAPSCREW (Dowel) -- 3/8-16 x 3/4 Lg.	Includes
	X2285		MANIFOLD ASSEM. - AIR STARTING 1 577-C4 3 ELBOW - Manifold to Cyl. Head 2 NIPPLE -- 1 1/4 x 5 1/2 Lg. 3 TEE -- 1 1/4 Std. 4 ELBOW -- 1 1/4 Std. 5 PIPE -- 1 1/4 x 14 Lg. (Thr'd. Both Ends) 6 NIPPLE -- 1 1/4 x 5 1/2 Lg. 7 NIPPLE -- 1 1/4 x 4 1/2 Lg. 8 ELBOW -- 1 1/4 - 45° Std. 9 X1583 1 NIPPLE ASSEM. - Manifold to Globe Valve	Includes
	X2287		CRANKSHAFT ASSEMBLY 1 CRANKSHAFT 1 GEAR 1 S-3109 1 PIN - Gear Dowel 1 655-M21 1 RING - Oil Thrower (Fwd. End) 1 655-E 1 RING - Oil Thrower (Aft End) 1 S-2918 1 PIN - Air Comp. Eccentric Dowel	Includes

ATLAS IMPERIAL DIESEL ENGINE CO. SUB-ASSEMBLY LIST

WHEN ORDERING PARTS ALWAYS GIVE ENGINE NUMBER - PART NUMBER - NAME - OR COMPLETE DESCRIPTION AND SIZE.

DO NOT ORDER PARTS BY REFERENCE NUMBERS

*INDICATES PARTS NOT SOLD INDIVIDUALLY

ASSEMBLY LIST NO. **AL-177**
 ISSUE **1**
 ENGINE SIZE **7 1/2 x 10 1/2 - 9 1/2**

REF. No.	PART NUMBER	No. USED	DESCRIPTION	
*	X2288		CRANKSHAFT ASSEMBLY	Includes
	1	1	CRANKSHAFT	
	2	1	GEAR	
	3	1	PIN - Gear Dowel	
	4	1	RING - Oil Thrower (Fwd. End)	
	5	1	RING - Oil Thrower (Aft End)	
	6	1	PIN - Air Comp. Eccentric Dowel	
*	X2289		SWIVEL ASSEM. - BRAKE POST (PLAIN)	Includes
	1	1	SWIVEL	
	2	2	STUD	
*	X2290		SWIVEL ASSEM. - BRAKE POST CROWDER	Includes
	1	1	SWIVEL	
	2	2	STUD - Pulorum	
*	X2291		HEAD ASSEM. - CYLINDER	Includes
	1	1	HEAD	
	2	2	PIPE PLUG - 1 Std.	
	3	2	GUIDE - Inlet & Exhaust Valve	
	4	1	STUD - Spray Valve Clamp	
	5	1	STUD - Hooker Shaft Bearing	
	6	2	STUD - Exhaust Elbow	
*	X2292		HEAD ASSEM. - CYLINDER	Includes
	1	1	HEAD ASSEM.	
	2	1	VALVE - Inlet	
	3	1	VALVE - Exhaust	
	4	2	WASHER - In. & Ex. Valve Spring (Bottom)	
	5	2	SPRING - In. & Ex. Valve	
	6	2	WASHER - Spring Retainer (Top)	
	7	4	NUT - 3/4-10-Hex.	
	8	1	LOCKWASHER -- 3/4 Shakeproof - Type 11	
	9	1	VALVE - Air Starting	
	10	1	CUSHION - Air Start. Valve	
	11	2	RING - Piston	
	12	1	SLEEVE - Air Start. Valve Spring	
	13	1	WASHER - Air Start. Valve Spring (Bottom)	
	14	1	SPRING - Air Start. Valve	
	15	1	WASHER - Air Start. Valve Spring (Top)	
	16	1	NUT -- 5/8-18-Hex.	
*	X2295		MANIFOLD ASSEM. - LUBE OIL	Includes
			Pipe, Inlet & Outlet Tees (No Service Parts)	
*	X2296		MANIFOLD ASSEM. - EXHAUST	Includes
	1	1	MANIFOLD	
	2	4	PIPE PLUG -- 1 1/4 Std.	
	3	1	REDUCING BUSHING -- 1 1/4 x 1/2 Std.	
	4	4	STUD - Inlet Elbow	
	5	4	STUD - (End)	
	6	1/4	C-2010L2	
	7	1/2	C-2010L2	
*	X2297		MANIFOLD ASSEM. - EXHAUST	Includes
	1	1	MANIFOLD	
	2	4	PIPE PLUG -- 1 1/4 Std.	
	3	1	REDUCING BUSHING -- 1 1/4 x 1/2 Std.	
	4	4	STUD - Inlet Elbow	
	5	4	STUD - (End)	
	6	1/4	C-2010L2	
	7	1/2	C-2010L2	
*	X2298		SWIVEL ASSEM. - BRAKE POST CROWDER	Includes
	1	1	SWIVEL	
	2	2	STUD - Pulorum	
*	X2299		CROWDER ASSEM. - BRAKE POST	Includes
	1	1	CROWDER	
	2	1	STUD - Control Link	
	3	1	C-7881	
*	X2301		ROCKER ASSEM. - INLET VALVE	Includes
	1	1	ROCKER	
	2	2	BUSHING	
	3	1	ROLLER	
	4	1	PIN - Roller	
	5	1	BALL CHECK ASSEM.	
	6	1	S20A-RS	
	7	1	S23-E	
	8	1	S24-E	
	9	1	S24-E	
	10	1	G827A-E	
*	X2302		ROCKER ASSEM. - EXHAUST VALVE	Includes
	1	1	ROCKER	
	2	2	BUSHING	
	3	1	ROLLER	
	4	1	PIN - Roller	
	5	1	BALL CHECK ASSEM.	
	6	1	S20A-RS	
	7	1	S23-E	
	8	1	S24-E	
	9	1	S24-E	
	10	1	G827A-E	

REF. No.	PART NUMBER	No. USED	DESCRIPTION	
*	X2303		ROCKER ASSEM. - AIR STARTING VALVE	Includes
	1	1	ROCKER	
	2	2	BUSHING	
	3	1	ROLLER	
	4	1	PIN - Roller	
	5	1	BALL CHECK ASSEM.	
	6	1	S20A-RS	
	7	1	S23-E	
	8	1	S24-E	
	9	1	S24-E	
	10	1	G827A-E	
*	X2304		DOOR ASSEM. - ROTARY PUMP	Includes
	1	1	DOOR	
	2	1	CAP - Pump Gear	
	3	2	GASKET - Cap	
	4	4	CAPSCREW -- 1/2-13 x 3 3/4 Ig.	
	5	1	CAP - Pump Clamp	
	6	2	CAPSCREW -- 1/2-13 x 2 1/4 Ig.	
*	X2305		CRANKSHAFT ASSEMBLY	Includes
	1	1	CRANKSHAFT	
	2	1	GEAR	
	3	1	PIN - Gear Dowel	
	4	2	RING - Oil Thrower	
	5	1	PIN - Dowel (Air Comp. Eccentric or Pump Drive Sprocket)	
	6	1	PIPE PLUG -- 1/4 Std. - C't's'k. Hd.	
	7	1	S20A-RS	
	8	1	S23-E	
	9	1	S24-E	
	10	1	S24-E	
	11	1	G827A-E	
*	X2306		CRANKSHAFT ASSEMBLY	Includes
	1	1	CRANKSHAFT	
	2	1	GEAR	
	3	1	PIN - Gear Dowel	
	4	2	RING - Oil Thrower	
	5	1	PIN - Dowel (Air Comp. Eccentric or Pump Drive Sprocket)	
	6	1	PIPE PLUG -- 1/4 Std. - C't's'k. Hd.	
	7	1	S20A-RS	
	8	1	S23-E	
	9	1	S24-E	
	10	1	S24-E	
	11	1	G827A-E	
*	X2307		BODY ASSEM. - GOVERNOR	Includes
	1	1	BODY ASSEM.	
	2	2	WRIGHT ASSEM.	
	3	2	PIN - Gov. Weight	
	4	4	CASTLE NUT -- 3/8-24-Hex.	
	5	4	COTTER PIN -- 3/32 x 3/4 Ig.	
	6	1	QUILL ASSEM. - Thrust	
	7	1	KEY - Thrust Quill	
	8	1	BALL BEARING - Thrust	
	9	1	X271	
	10	1	X270	
	11	1	SC1880	
	12	1	X266	
	13	1	C-548	
	14	1	S720	
*	X2310		MANIFOLD ASSEM. - SPRAY VALVE DRAIN	Includes
			Pipe & Tees (No Service Parts)	
*	X2311		MANIFOLD ASSEM. - SPRAY VALVE DRAIN	Includes
			Pipe & Tees (No Service Parts)	
*	X2314		PLATFORM ASSEMBLY	Includes
			Platform & Angle (No Service Parts)	
*	X2315		PLATFORM ASSEMBLY	Includes
			Platform & Angle (No Service Parts)	
*	X2426		BASE ASSEMBLY	Includes
	1	1	BASE	
	2	2	PIPE PLUG -- 1 1/2 Std.	
	3	3	PIN - Crank, Brg. Shell Dowel	
	4	14	STUD - Crank, Brg. Cap	
	5	11	STUD - Base, Centerframe & Cylinder	
	6	1	STUD - Base & Centerframe	
	7	2	STUD - Base & Centerframe (End)	
	8	1	MANIFOLD ASSEM. - Lube Oil	
	9	2	PIPE PLUG -- 3/8 Std.	
	10	4	CLAMP - Manifold to Base	
	11	8	CAPSCREW - Manifold Clamp to Base	
	12	6	TUBE - Manifold to Crank. Brg. Oil	
	13	6	WASHER - Crank. Brg. Oil Tube	
	14	2	CAP - Crankshaft Bearing (End)	
	15	3	CAP - Crankshaft Bearing	
	16	14	NUT - Crankshaft Bearing Cap	
	17	14	COTTER PIN -- 1/8 x 1 1/2 Ig.	
	18	1	C-2406L 1/2	
	19	1	S23543	
	20	1	C-3962	
	21	1	F-6194	
	22	1	W13-B	
	23	1	S-2713	

ATLAS IMPERIAL DIESEL ENGINE CO. SUB-ASSEMBLY LIST

WHEN ORDERING PARTS ALWAYS GIVE ENGINE NUMBER - PART NUMBER - NAME - OR COMPLETE DESCRIPTION AND SIZE.
DO NOT ORDER PARTS BY REFERENCE NUMBERS
*INDICATES PARTS NOT SOLD INDIVIDUALLY

REF. No.	PART NUMBER	No. USED	DESCRIPTION	
	X2427		BASE ASSEMBLY	Includes
*		1	BASE	
		2	PIPE PLUG -- 1 1/2 Std.	
1	S-2918	6	PIN - Crank. Brg. Shell Dowel	
2	C-2112L5 3/4	16	STUD - Crank. Brg. Cap	
3	727-RE3	15	STUD - Base, Centerframe & Cylinder	
4	729-RE3	1	STUD - Base & Centerframe	
5	731-RE3	2	STUD - Base & Centerframe (End)	
6	X2234	1	MANIFOLD ASSEM. - Lube Oil	
		2	PIPE PLUG -- 3/8 Std.	
7	C-7865	5	CLAMP - Manifold to Base	
8	C-2406L 1/2	10	CAPSCREW - Manifold Clamp to Base	
9	202543	6	TUBE - Manifold to Crank. Brg. Oil	
10	C-3662	6	WASHER - Crank. Brg. Oil Tube	
11	F-5194	2	CAP - Crankshaft Bearing (End)	
12	713-R	4	CAP - Crankshaft Bearing	
13	S-2713	16	NUT - Crankshaft Bearing Cap	
		16	COTTER PIN -- 1/8 x 1 1/2 Lg.	
	X2428		CENTERFRAME ASSEMBLY	Includes
*		1	CENTERFRAME	
1	C-5520L5 1/4	1	STUD - Cylinder	
2	846A-RE3	3	STUD - Fuel Pump Housing	
4	S-1983	6	PIN - Centerframe Door Dowel	
	X2429		CENTERFRAME ASSEMBLY	Includes
*		1	CENTERFRAME	
1	C-5520L5 1/4	1	PIPE PLUG -- 1/2 Std. - C't's'k. Hl.	
2	846A-RE3	4	STUD - Fuel Pump Housing	
4	S-1983	7	PIN - Centerframe Door Dowel	
	X2448		BASE ASSEMBLY	Includes
*		1	BASE	
		4	PIPE PLUG -- 1 1/2 Std.	
1	S-2918	4	PIN - Crank. Brg. Shell Dowel	
2	C-2112L5 3/4	10	STUD - Crank. Brg. Cap	
3	727-RE3	11	STUD - Base, Centerframe & Cylinder	
4	729-RE3	1	STUD - Base & Centerframe	
5	731-RE3	2	STUD - Base & Centerframe (End)	
6	X2060	1	MANIFOLD ASSEM. - Lube Oil	
		2	PIPE PLUG -- 3/8 Std.	
		1	PIPE PLUG -- 1/8 Std. - C't's'k. Hl.	
7	C-7865	3	CLAMP - Manifold to Base	
8	C-2406L 1/2	6	CAPSCREW - Manifold Clamp to Base	
9	202543	4	TUBE - Manifold to Crank. Brg. Oil	
10	C-3662	4	WASHER - Crank. Brg. Oil Tube	
11	F-5194	1	CAP - Crankshaft Bearing (End)	
12	713-R	3	CAP - Crankshaft Bearing	
13	S-2713	10	NUT - Crankshaft Bearing Cap	
		10	COTTER PIN -- 1/8 x 1 1/2 Lg.	
	X2449		BASE ASSEMBLY	Includes
*		1	BASE	
		4	PIPE PLUG -- 1 1/2 Std.	
1	S-2918	5	PIN - Crank. Brg. Shell Dowel	
2	C-2112L5 3/4	12	STUD - Crank. Brg. Cap	
3	727-RE3	15	STUD - Base, Centerframe & Cylinder	
4	729-RE3	1	STUD - Base & Centerframe	
5	731-RE3	2	STUD - Base & Centerframe (End)	
6	X2061	1	MANIFOLD ASSEM. - Lube Oil	
		2	PIPE PLUG -- 3/8 Std.	
		1	PIPE PLUG -- 1/2 Std. - C't's'k. Hl.	
7	C-7865	4	CLAMP - Manifold to Base	
8	C-2406L 1/2	6	CAPSCREW - Manifold Clamp to Base	
9	202543	6	TUBE - Manifold to Crank. Brg. Oil	
10	C-3662	5	WASHER - Crank. Brg. Oil Tube	
11	F-5194	1	CAP - Crankshaft Bearing (End)	
12	713-R	4	CAP - Crankshaft Bearing	
13	S-2713	12	NUT - Crankshaft Bearing Cap	
		12	COTTER PIN -- 1/8 x 1 1/2 Lg.	
	X2450		CENTERFRAME ASSEMBLY	Includes
*		1	CENTERFRAME	
1	C-5520L5 1/4	1	STUD - Cylinder	
2	846A-RE3	3	STUD - Fuel Pump Housing	
3	C-5510L3	4	STUD - Air Compressor Cylinder	
4	S-1983	6	PIN - Centerframe Door Dowel	
	X2451		CENTERFRAME ASSEMBLY	Includes
*		1	CENTERFRAME	
1	C-5520L5 1/4	1	STUD - Cylinder	
2	846A-RE3	3	STUD - Fuel Pump Housing	
3	C-5510L3	4	STUD - Air Compressor Cylinder	
4	S-1983	6	PIN - Centerframe Door Dowel	

REF. No.	PART NUMBER	No. USED	DESCRIPTION	
	X2452		CENTERFRAME ASSEMBLY	Includes
*		1	CENTERFRAME	
		1	PIPE PLUG -- 1/2 Std. -- C't's'k. Hl.	
1	C-5520L5 1/4	1	STUD - Cylinder	
2	846A-RE3	4	STUD - Fuel Pump Housing	
3	C-5510L3	4	STUD - Air Compressor Cylinder	
4	S-1983	7	PIN - Centerframe Door Dowel	
	X2453		CENTERFRAME ASSEMBLY	Includes
*		1	CENTERFRAME	
		1	PIPE PLUG -- 1/2 Std. -- C't's'k. Hl.	
1	C-5520L5 1/4	1	STUD - Cylinder	
2	846A-RE3	4	STUD - Fuel Pump Housing	
3	C-5510L3	4	STUD - Air Compressor Cylinder	
4	S-1983	7	PIN - Centerframe Door Dowel	
	X2605		VALVE & GAGE ASSEM.-PUMP SUCTION & DISCHARGE	Includes
1	X2608	1	GAGE ASSEM.	
2	S-2799	1	VALVE - Suction	
3	S-561	1	SPRING - Suction Valve	
4	S-563	1	WASHER - Suction Valve Spring Retainer	
		1	COTTER PIN -- 1/16 x 1/2 Lg.	
6	C-9586	1	CAP - Suction Valve Stem	
7	C-9524	1	VALVE - Discharge	
	X2608		GAGE ASSEM.-FUEL PUMP SUCTION & DISCHARGE VALVE	Includes
			Gage & Discharge Valve Seat (No Service Parts)	
	X2612		BAND ASSEM. - PROPELLER SHAFT BRAKE	Includes
*		1	BAND	
		2	RIVET -- 1/4 Dia. x 1/4 Lg.-Rnd. Hl.	
1	C-7842	1	LINING	
2		24	RIVET -- 3/16 Dia. x 5/16 Lg. - Tabular	
	X2721		BEARING ASSEM. - CAMSHAFT END	Includes
*		1	BEARING	
1	S23885	1	BUSHING	
2		1	OIL SEAL -- National Motor Brg. Co. #50083	
		2	PIPE PLUG -- 1/8 Std.	
	X2791		ADAPTOR ASSEM. - LUBE PRESS. PUMP	Includes
*		1	ADAPTOR	
1	5855	2	BUSHING - Pump Shaft	
	X2792		ADAPTOR ASSEM. - LUBE PRESS. PUMP	Includes
*		1	ADAPTOR	
1	5855	2	BUSHING - Pump Shaft	
		1	PIPE PLUG -- 1/8 Std.	
	X2825		PUMP ASSEM. - LUBE OIL SUMP & PRESSURE	Includes
1	X2826	1	BODY ASSEM. - Press. Pump	
2	X2827	1	GEAR & SHAFT ASSEM. - Press. Pump (Drive)	
3	X2828	1	GEAR & SHAFT ASSEM. - Press. Pump (Driven)	
4	C-6695	1	SPACER - Pump Body	
5	C-6693	2	GASKET - Spacer	
6	C-9281	1	GEAR - Sump Pump (Drive)	
7		2	WOODRUFF KEY -- 1/8 x 3/4 Std.	
8	C-9280	1	GEAR - Sump Pump (Driven)	
9	W-1274	1	BODY - Sump Pump	
		4	NUT -- 3/8-24-Hex.	
		4	LOCKWASHER -- 3/8 SAE Reg.	
10	C-7402	2	PIN - Dowel	
	X2826		BODY ASSEM. - LUBE OIL PRESSURE PUMP	Includes
*		1	BODY	
1	C-2106L4	4	STUD	
	X2827		GEAR & SHAFT ASSEM. - PRESSURE PUMP (DRIVE)	Includes
1	C-6695	1	GEAR	
2	C-9916	1	SHAFT	
3		1	WOODRUFF KEY -- 1/8 x 3/4 Std.	
	X2828		GEAR & SHAFT ASSEM. - PRESSURE PUMP (DRIVEN)	Includes
1	C-3024	1	GEAR	
2	C-9914	1	SHAFT	

ATLAS IMPERIAL DIESEL ENGINE CO. SUB-ASSEMBLY LIST

WHEN ORDERING PARTS ALWAYS GIVE ENGINE NUMBER-PART NUMBER-NAME-OR COMPLETE DESCRIPTION AND SIZE.

DO NOT ORDER PARTS BY REFERENCE NUMBERS

*INDICATES PARTS NOT SOLD INDIVIDUALLY

ASSEMBLY LIST NO. AL-181
 ENGINE SIZE 7 1/2 x 10 1/2 - 9 1/2

REF. No.	PART NUMBER	No. USED	DESCRIPTION	
	X2853		BASE ASSEMBLY	Includes
*		1	BASE	
		4	PIPE PLUG -- 2 Std.	
1	S-2918	4	FIN - Crank. Bear. Shell Dowel	
2	C-2112L6 1/4	10	STUD - Crank. Bearing Cap	
3	C-5822L26 1/2	11	STUD - Base, Centerframe & Cylinder	
4	C-5822L21	1	STUD - Base & Centerframe	
5	C-5812L19	2	STUD - Base & Centerframe (End)	
6	X2277	1	MANIFOLD ASSEM. - Lube Oil	
		2	PIPE PLUG -- 3/8 Std.	
		1	PIPE PLUG -- 1/2 Std. - C't's'k. Hl.	
7	C-9511	3	CLAMP - Manifold to Base	
8	C-2406L 1/2	6	CAPSCREW - Clamp to Base	
9	C-1362	4	TUNE - Man. to Crank. Bear. Oil	
10	C-3662	4	WASHER - Crank. Bear. Oil Tube	
11	P-5240	1	CAP - Crankshaft Bearing (End)	
12	713-832	3	CAP - Crankshaft Bearing	
13	S-2713	10	NUT - Crankshaft Bearing Cap	
		10	COTTER PIN -- 1/8 x 1 1/2 Lg.	
	X2854		BASE ASSEMBLY	Includes
*		1	BASE	
		4	PIPE PLUG -- 2 Std.	
1	S-2918	4	FIN - Crank. Bear. Shell Dowel	
2	C-2112L6 1/4	18	STUD - Crank. Bearing Cap	
3	C-5822L26 1/2	15	STUD - Base, Centerframe & Cylinder	
4	C-5822L21	1	STUD - Base & Centerframe	
5	C-5812L19	2	STUD - Base & Centerframe (End)	
6	X2297	1	MANIFOLD ASSEM. - Lube Oil	
		2	PIPE PLUG -- 3/8 Std.	
		1	PIPE PLUG -- 1/2 Std. - C't's'k. Hl.	
7	C-9511	4	CLAMP - Manifold to Base	
8	C-2406L 1/2	6	CAPSCREW - Clamp to Base	
9	C-1362	6	TUNE - Man. to Crank. Bear. Oil	
10	C-3662	6	WASHER - Crank. Bear. Oil Tube	
11	P-5240	1	CAP - Crankshaft Bearing (End)	
12	713-832	4	CAP - Crankshaft Bearing	
13	S-2713	12	NUT - Crankshaft Bearing Cap	
		12	COTTER PIN -- 1/8 x 1 1/2 Lg.	
	X2855		CENTERFRAME ASSEMBLY	Includes
*		1	CENTERFRAME	
1	C-5822L9 1/2	1	STUD - Cylinder	
2	846A-RB3	3	STUD - Fuel Pump Housing	
3	C-5810L3	4	STUD - Air Compressor Cylinder	
4	S-1983	5	FIN - Centerframe Door Dowel	
	X2856		CENTERFRAME ASSEMBLY	Includes
*		1	CENTERFRAME	
1	C-5822L9 1/2	1	STUD - Cylinder	
2	846A-RB3	3	STUD - Fuel Pump Housing	
3	C-5810L3	4	STUD - Air Compressor Cylinder	
4	S-1983	5	FIN - Centerframe Door Dowel	
	X2857		CENTERFRAME ASSEMBLY	Includes
*		1	CENTERFRAME	
1	C-5822L9 1/2	1	STUD - Cylinder	
2	846A-RB3	4	STUD - Fuel Pump Housing	
3	C-5810L3	4	STUD - Air Compressor Cylinder	
4	S-1983	7	FIN - Centerframe Door Dowel	
	X2858		CENTERFRAME ASSEMBLY	Includes
*		1	CENTERFRAME	
1	C-5822L9 1/2	1	STUD - Cylinder	
2	846A-RB3	4	STUD - Fuel Pump Housing	
3	C-5810L3	4	STUD - Air Compressor Cylinder	
4	S-1983	7	FIN - Centerframe Door Dowel	
	X3068		BODY ASSEM. - GOVERNOR	Includes
*		1	BODY	
1	S-806	1	FINION - Drive	
2		1	WOODRUFF KEY -- 1/8 x 5/8 Std.	
	X3178		MANIFOLD ASSEM. - AIR STARTING	Includes
1	577-04	3	ELBOW - Manifold to Cyl. Head	
2		3	NIPPLE -- 1 1/4 x 5 1/2 Lg.	
3		2	TIE -- 1 1/4 Std.	
4		1	ELBOW -- 1 1/4 Std.	
5		2	PIPE -- 1 1/4 x 14 Lg. - (Thr'd. Both Ends)	
6		1	NIPPLE -- 1 1/4 x 5 1/2 Lg.	
7		1	NIPPLE -- 1 1/4 x 4 1/2 Lg.	
8		2	ELBOW -- 1 1/4 - 45° Std.	
9	X1583	1	NIPPLE ASSEM. - Manifold to Globe Valve	
	X3184		ACCUMULATOR ASSEM. - FUEL	Includes
			Body, Upper & Lower Plugs & Flange (No Service Parts)	
	X3225		HEAD ASSEM. - H.P. FUEL PUMP	Includes
*		1	HEAD	
1	2C183NL 1/8	1	PIPE PLUG	
	X3226		HEAD ASSEM. - H.P. FUEL PUMP	Includes
*		1	HEAD	
1	2C183NL 1/8	1	PIPE PLUG	

REF. No.	PART NUMBER	No. USED	DESCRIPTION	
	X3227		PUMP ASSEM. - FUEL PRIMING	Includes
*		1	BODY	
		1	FLUNGER - Pump	
1		1	PACKING -- 1/8 Rd. x 7 Lg. - (Petrol)	
2	S-2065	1	WASHER - Packing	
3	S-2064	1	NUT - Packing	
	X3233		ACCUMULATOR ASSEM. - FUEL	Includes
			Body, Lower & Upper Plugs & Adaptor Flange (No Service Parts)	
	X3236		CRANK ASSEM. - FUEL PUMP	Includes
*		1	CRANK	
1	2C2129	1	SHAFT - Tachometer Drive	
		1	SETScrew--1/4-20 x 3/8 Lg. Headless Cup Pt.	
	X3237		BEARING ASSEM. - CAMSHAFT	Includes
*		1	BEARING	
1	C-308	1	BUSHING	
	X3288		GOVERNOR ASSEMBLY	Includes
1	X2068	1	BODY ASSEM.	
2	X265	2	WEIGHT ASSEM.	
3	2C1620	2	PIE - Weight to Body	
4		4	CASTLE NUT -- 3/8-24-Hex.	
5	X266	1	QUILL ASSEM. - Gov. Thrust	
6	C-548	1	KEY - Thrust Quill	
7	5721	1	THRUST BEARING - Benton "OBLIGE"	
8	2C1767	1	RETAINDER - Bearing	
9	2C2846L 7/8	1	SCREW	
		1	WIRE -- #16 Ga. x 9 Lg.	
	X3362		ADAPTOR ASSEM. - FUEL TRANSFER PUMP	Includes
*		1	ADAPTOR	
1	2C2477	1	BUSHING	
2		1	BEARING - Pump Shaft	
3	C-9882	1	BUSHING - Bearing (Gear End)	
3	2C2477	1	BUSHING - Bearing (Seal End)	
		3	PIPE PLUG -- 1/8 Std.	
4	C-8176	1	GASKET - Bearing to Adaptor	
5	C-2406L 7/8	3	CAPSCREW - Bearing to Adaptor	
		1	WIRE -- #16 Ga. x 9 Lg.	
	X3376		MANIFOLD ASSEM. - AIR INLET	Includes
			Manifold & Flanges (No Service Parts)	
	X3480		CENTERFRAME ASSEMBLY	Includes
*		1	CENTERFRAME	
1	C-5822L9 1/2	1	STUD - Cylinder	
2	846A-RB3	3	STUD - Fuel Pump Housing	
4	S-1983	5	FIN - Centerframe Door Dowel	
	X3481		CENTERFRAME ASSEMBLY	Includes
*		1	CENTERFRAME	
1	C-5822L9 1/2	1	STUD - Cylinder	
2	846A-RB3	4	STUD - Fuel Pump Housing	
4	S-1983	7	FIN - Centerframe Door Dowel	
	X3482		BASE ASSEMBLY	Includes
*		1	BASE	
		4	PIPE PLUG -- 2 Std.	
1	S-2918	5	FIN - Crank. Bear. Shell Dowel	
2	C-2112L6 1/4	14	STUD - Crank. Bearing Cap	
3	C-5822L26 1/2	11	STUD - Base, Centerframe & Cylinder	
4	C-5822L21	1	STUD - Base & Centerframe	
5	C-5812L19	2	STUD - Base & Centerframe (End)	
6	X2895	1	MANIFOLD ASSEM. - Lube Oil	
		2	PIPE PLUG -- 3/8 Std.	
		1	PIPE PLUG -- 1/2 Std. - C't's'k. Hl.	
7	C-9511	4	CLAMP - Manifold to Base	
8	C-2406L 1/2	6	CAPSCREW - Clamp to Base	
9	C-1362	6	TUNE - Man. to Crank. Bear. Oil	
10	C-3662	6	WASHER - Crank. Bear. Oil Tube	
11	P-5240	2	CAP - Crankshaft Bearing (End)	
12	713-832	3	CAP - Crankshaft Bearing	
13	S-2713	14	NUT - Crankshaft Bearing Cap	
		14	COTTER PIN -- 1/8 x 1 1/2 Lg.	

ISSUE ASSEMBLY NO. AL182
ENGINE SIZE 7 1/2 x 10 1/2 - 9 x 12

ATLAS IMPERIAL DIESEL ENGINE CO. SUB-ASSEMBLY LIST

WHEN ORDERING PARTS ALWAYS GIVE ENGINE NUMBER - PART NUMBER - NAME - OR COMPLETE DESCRIPTION AND SIZE.
DO NOT ORDER PARTS BY REFERENCE NUMBERS
*INDICATES PARTS NOT SOLD INDIVIDUALLY

REF. No.	PART NUMBER	No. USED	DESCRIPTION	
	X3483		BASE ASSEMBLY	Includes
	1	1	BASE	
	4	4	PIPE PLUG -- 2 Std.	
1	S-2918	6	PIN - Crank. Bear. Shell Dowel	
2	C-2112L6 1/4	16	STUD - Crank. Bearing Cap	
3	C-5522L2 1/2	15	STUD - Base, Centerframe & Cylinder	
4	C-5522L21	1	STUD - Base & Centerframe	
4	C-5522L19	2	STUD - Base & Centerframe (End)	
5	X2278	1	MANIFOLD ASSEM. - Lube Oil	
6		2	PIPE PLUG -- 3/8 Std.	
7		1	PIPE PLUG -- 1/2 Std. - C's's'k. M.	
7	C-9511	5	CLAMP - Manifold to Base	
8	C-2406L 1/2	10	CAPSCREW - Clamp to Base	
9	C-1358	6	TUBE - Man. to Crank. Bear. Oil	
10	C-3688	6	WASHER - Crank. Bear. Oil Tube	
11	P-5240	2	CAP - Crankshaft Bearing (End)	
12	713-252	4	CAP - Crankshaft Bearing	
13	S-2713	16	NUT - Crankshaft Bearing Cap	
		16	COTTER PIN -- 1/8 x 1 1/2 Lg.	
	X3484		GOVERNOR ASSEMBLY	Includes
1	X2068	1	BODY ASSEM.	
2	X265	2	WEIGHT ASSEM.	
3	SC1820	2	PIN - Weight to Body	
4		4	CASTLE NUT -- 3/8-24-Hex.	
		4	COTTER PIN -- 3/32 x 3/4 Lg.	
5	X266	1	QUILL ASSEM. - Gov. Thruat	
6	C-548	1	KEY - Thruat Quill	
7	5721	1	THRUST BEARING -- Bantex "OBLIGE"	
8	SC1757	1	RETAINER - Bearing	
9	SC2846L 7/8	1	SETSCREW	
	X3485		GOVERNOR ASSEMBLY	Includes
1	X2068	1	BODY ASSEM.	
2	X270	2	WEIGHT ASSEM.	
3	SC1820	2	PIN - Weight to Body	
4		4	CASTLE NUT -- 3/8-24-Hex.	
		4	COTTER PIN -- 3/32 x 3/4 Lg.	
5	X266	1	QUILL ASSEM. - Gov. Thruat	
6	C-548	1	KEY - Thruat Quill	
7	5721	1	THRUST BEARING -- Bantex "OBLIGE"	
8	SC1757	1	RETAINER - Bearing	
9	SC2846L 7/8	1	SETSCREW	
	X3642		BASE ASSEMBLY	Includes
	1	1	BASE	
1	S-2918	6	PIN - Bear. Shell Dowel	
2	C-2979	8	CONNECTOR - Oil Tube	
3	C-2112L5 3/4	16	STUD - Bear. Cap	
4	757-BE3	23	STUD - Base, Centerframe & Cylinder	
5	789-BE3	1	STUD - Base & Centerframe (End - Large)	
6	C-2012L10 1/4	2	STUD - Base & Centerframe (Aft End - Small)	
7	713-E	7	CAP - Bearing	
8	SC3482	1	CAP - Bearing (Aft End)	
9	S-2713	16	NUT - Bearing Cap	
		16	COTTER PIN -- 1/8 x 1 1/2 Lg.	
		2	PIPE PLUG -- 1 Std. - C's's'k. M.	
		1	PIPE PLUG (Gump) -- 1/2 Std.	
	X3643		SEAL ASSEM. - CRANKSHAFT OIL	Includes
	2	2	SEAL	
1	C-7685	2	GASKET	
		2	CAPSCREW -- 3/8-16 x 1 1/2 Lg.	
		2	NUT -- 3/8-16-Hex.	
		2	LOCKWASHER -- 3/8 SAE Reg.	
	X3644		CRANKSHAFT ASSEMBLY	Includes
	1	1	CRANKSHAFT	
1	SC3483	1	BEAR	
2	SC2891L	2	PIN - Eccentric & Sprocket Drive	
3	C-5209	1	PIN - Eccentric Dowel	
	X3645		ECCENTRIC ASSEM. - AIR COMPRESSOR	Includes
	1	1	ECCENTRIC	
	1	1	ECCENTRIC	
1	C-6846L 7/8	2	PIN - Dowel	
2	C-2108L3 1/2	4	STUD	
		4	CASTLE NUT -- 1/2-20-Hex.	
		4	COTTER PIN -- 3/32 x 1 Lg.	
	X3646		SPROCKET ASSEM. - WATER PUMP DRIVE	Includes
	2	2	SPROCKET - (Halves)	
1	C-2108L3	2	STUD	
		2	CASTLE NUT -- 1/2-20-Hex.	
		2	COTTER PIN -- 3/32 x 1 Lg.	
	X3647		STRAINER ASSEM. - LUBE OIL	Includes
			Strainer Body & Screen (No Service Parts)	

REF. No.	PART NUMBER	No. USED	DESCRIPTION	
	X3648		MANIFOLD ASSEM. - LUBE OIL	Includes
			Pipe & Inlet & Outlet Connections (No Service Parts)	
	X3649		MANIFOLD ASSEM. - LUBE OIL	Includes
			Pipe & Inlet & Outlet Connections (No Service Parts)	
	X3650		CYLINDER ASSEMBLY	Includes
	1	1	CYLINDER	
	4	4	PIPE PLUG -- 1 1/4 Std.	
1	S-2262	4	STUD - Cyl. Head (Short)	
2	SC3538	2	STUD - Cyl. Head (Long)	
3	600-N	1	COVER - Clean-out	
4	608A-N	1	GASKET - Cover	
		4	CAPSCREW -- 1/8-13 x 1 1/4 Lg.	
5	C-264	2	NIPPLE - Lube Oil	
6	612-R	2	GLAND - Packing	
7	610A-RB3	2	OROMMET	
8	S-2914	4	WASHER	
	X3651		HEAD ASSEM. - CYLINDER	Includes
	1	1	HEAD	
	6	6	PIPE PLUG -- 3/4 Std.	
	6	6	PIPE PLUG -- 1 Std.	
1	512-R51	2	GUIDE - In. & Sh. Valve	
2	854A-R	1	STUD - Spray Valve Clamp	
3	SC3539	4	STUD - Rocker Shaft Bearing	
	X3652		HEAD ASSEM. - CYLINDER	Includes
1	X3651	1	HEAD ASSEM.	
2	P-3275	1	VALVE - Inlet	
3	P-3276	1	VALVE - Exhaust	
4	513-R	2	SPRING - Valve	
5	514A-FXC4	2	WASHER - Valve Spring (Bottom)	
6	514-FXC4	2	WASHER - Valve Spring (Top)	
7		4	HALF NUT -- 5/8-11-Hex.	
8		2	LOCKWASHER -- Shakeproof - Type 11 - 5/8	
9	SC3542	1	GUIDE - Air Start. Check Valve	
		2	CAPSCREW -- 1/2-13 x 1 1/4 Lg.	
		2	LOCKWASHER -- 1/2 SAE Reg.	
10	SC3540	1	VALVE - Air Start. Check	
11	SC3543	1	SPRING - Air Start. Check Valve	
12	SC3541	1	RETAINER - Air Start. Check Valve Spring	
		1	COTTER PIN -- 3/32 x 7/8 Lg.	
	X3653		CYLINDER ASSEMBLY	Includes
	1	1	CYLINDER	
	6	6	PIPE PLUG -- 1 1/4 Std.	
1	S-2262	4	STUD - Cyl. Head (Short)	
2	SC3538	2	STUD - Cyl. Head (Long)	
3	600-N	1	COVER - Clean-out	
4	608A-N	1	GASKET - Cover	
		4	CAPSCREW -- 1/8-13 x 1 1/4 Lg.	
5	C-264	2	NIPPLE - Lube Oil	
6	612-R	2	GLAND - Packing	
7	610A-RB3	2	OROMMET	
8	S-2914	4	WASHER	
9	610-RB3	2	NIPPLE - Water By-Pass	
	X3654		HEAD ASSEM. - CYLINDER	Includes
	1	1	HEAD - Cylinder	
	6	6	PIPE PLUG -- 3/4 Std.	
	6	6	PIPE PLUG -- 1 Std.	
1	512-R51	2	GUIDE - In. & Sh. Valve	
2	854A-R	1	STUD - Spray Valve Clamp	
3	SC3539	4	STUD - Rocker Shaft Bearing	
	X3655		HEAD ASSEM. - CYLINDER	Includes
1	X3654	1	HEAD ASSEM.	
2	P-3275	1	VALVE - Inlet	
3	P-3276	1	VALVE - Exhaust	
4	513-R	2	SPRING - Valve	
5	514A-FXC4	2	WASHER - Valve Spring (Bottom)	
6	514-FXC4	2	WASHER - Valve Spring (Top)	
7		4	HALF NUT -- 5/8-11-Hex.	
8		2	LOCKWASHER -- 5/8 Shakeproof -- Type 11	
9	SC3542	1	GUIDE - Air Start. Check Valve	
		2	CAPSCREW -- 1/2-13-SC x 1 1/4 Lg.	
		2	LOCKWASHER -- 1/2 SAE Reg.	
10	SC3540	1	VALVE - Air Start. Check	
11	SC3543	1	SPRING - Air Start. Check Valve	
12	SC3541	1	RETAINER - Air Start. Check Valve Spring	
		1	COTTER PIN -- 3/32 x 7/8 Lg.	
	X3656		CENTERFRAME ASSEMBLY	Includes
	1	1	CENTERFRAME	
1	C-5520L9 1/4	1	STUD - Cylinder	
2	846A-RB3	4	STUD - Piel Pump Housing	
3	C-5510L3	4	STUD - Air Comp. Cylinder	
4	S-1963	13	PIN - Centerframe Door Dowel	

ATLAS IMPERIAL DIESEL ENGINE CO. SUB-ASSEMBLY LIST

WHEN ORDERING PARTS ALWAYS GIVE ENGINE NUMBER - PART NUMBER - NAME - OR COMPLETE DESCRIPTION AND SIZE.
DO NOT ORDER PARTS BY REFERENCE NUMBERS
*INDICATES PARTS NOT SOLD INDIVIDUALLY

ENGINE SIZE 1250E
 ASSEMBLY NO. AL 183
 1
 7 1/2 x 10 1/2 x 9 x 12

REF. No.	PART NUMBER	No. USED	DESCRIPTION	
	X3657		CENTERFRAME ASSEMBLY	Includes
*			1 CENTERFRAME	
1	C-552029 1/4	1	STUD - Cylinder	
2	846L-RB3	4	STUD - Fuel Pump Housing	
3	C-651013	4	STUD - Air Compressor Cylinder	
4	8-1983	11	PIN - Centerframe Door Dowel	
	X3658		BRACKET ASSEM. - INTERMEDIATE GEAR	Includes
*			1 BRACKET	
1	C-7880	1	PIN - Gear	
2	8-2760	1	PIN - Dowel	
3	8-2920	1	STUD - Gear Pin End	
4	C-7942	4	STUD - Bracket	
5	8C3582	1	BUSHING - Tachometer Drive Shaft	
	X3659		BRACKET ASSEM. - INTERMEDIATE GEAR	Includes
*			1 BRACKET	
1	C-7880	1	PIN - Gear	
2	8-2760	1	PIN - Dowel	
3	8-2920	1	STUD - Gear Pin End	
4	C-7942	4	STUD - Bracket	
5	8C3582	1	BUSHING - Tachometer Drive Shaft	
	X3660		GEAR ASSEM. - INTERMEDIATE	Includes
*			1 GEAR	
1	854B-A33	1	BUSHING	
		2	CAPSCREW -- 1/2-13 x 1 Lg.	
	X3661		LIFTER ASSEM. - FUEL PUMP	Includes
*			1 LIFTER	
1	8C3582	1	ROLLER	
2	8C3582	1	PIN - Roller	
	X3662		PUMP ASSEM. - BILGE	Includes
1	W-2800	1	BOUY	
		1	PIPE PLUG -- 1 Std.	
2	X3666	1	PLUNGER ASSEM.	
3		5	PACKING -- 3/8 Sq. x 8 Lg. - (Flax)	
4	X3710	1	GLAND ASSEM. - Packing	
		4	NUT -- 1/2-13-Hex.	
	X3663		PUMP ASSEM. - BILGE	Includes
1	W-2801	1	BOUY	
		1	PIPE PLUG -- 1 Std.	
2	X3666	1	PLUNGER ASSEM.	
3		5	PACKING -- 3/8 Sq. x 8 Lg. - (Flax)	
4	X3710	1	GLAND ASSEM. - Packing	
		4	NUT -- 1/2-13-Hex.	
	X3666		PLUNGER ASSEM. - BILGE PUMP	Includes
*			1 PLUNGER	
		1	PIPE PLUG -- 1 Std.	
	X3667		ROD ASSEM. - BILGE PUMP CONNECTING	Includes
*			1 ROD	
		1	CAP	
1	C-211014 1/4	2	STUD	
2		2	CASTLE NUT -- 5/8-18-Hex.	
		2	COTTER PIN -- 1/8 x 1 1/4 Lg.	
3	C-601111 3/8	2	SCOTCHMAN PIN -- #10 x 1 1/8 Lg.	
		2	PIN - Stud Retainer	
	X3668		GOVERNOR ASSEMBLY	Includes
1	83669	1	BODY ASSEM.	
2	8245	2	WRIGHT ASSEM.	
3	8C1880	2	PIN - Weight to Body	
4		4	CASTLE NUT -- 3/8-24-Hex.	
4		4	COTTER PIN -- 3/8 x 3/4 Lg.	
5	8246	1	QUILL ASSEM. - Thrust	
6	C-548	1	KEY - Thrust Quill	
7	8721	1	THRUST BEARING -- Bantam "OBLOS"	
8	8C1787	1	RETAINER - Bearing	
9	8C2842L 7/8	1	SCREWS	
		1	WIRE -- #16 Ga. x 9 Lg.	
	X3669		BOUY ASSEM. - GOVERNOR	Includes
*			1 BOUY	
1	8C8686	1	PINION	
2		1	WOODRUFF KEY -- 1/8 x 5/8 Std.	

REF. No.	PART NUMBER	No. USED	DESCRIPTION	
	X3670		CAMSHAFT ASSEMBLY	Includes
*			1 CAMSHAFT	
1	C-7972L 1/2	1	PIN - Shift. Coller Retainer Washer	
2	8C3580	1	ECCENTRIC - Fuel Pump	
3	C-6708L3 1/2	1	KEY - Eccentric & Lube Pump Gear	
4	8C3519	2	KEY - Bilge Pump Eccentric Sleeve	
		4	MACHINE SCREW--1/4-20 x 3/4 Lg.-Flat Hd.	
	X3671		BEARING ASSEM. - CAMSHAFT (P.W.D. END)	Includes
*			1 BEARING	
1	8C3618	1	BUSHING	
	X3672		BEARING ASSEM. - CAMSHAFT (P.W.D. END)	Includes
*			1 BEARING	
1	8C3618	1	BUSHING	
	X3673		BEARING ASSEM. - CAMSHAFT (INTERMED.)	Includes
*			1 BEARING	
1	8C3618	1	BUSHING	
	X3674		BEARING ASSEM.-CAMSHAFT(INTERM. - LARGE)	Includes
*			1 BEARING	
1	8C3637	1	BUSHING	
	X3675		BEARING ASSEM.-CAMSHAFT(INTERM. - LARGE)	Includes
*			1 BEARING	
1	8C3637	1	BUSHING	
	X3676		BEARING ASSEM.-CAMSHAFT(& BILGE PUMP ECCENT.)	Includes
1	X3678	1	BEARING ASSEM.	
2	8C3517	1	SLEEVE - Bilge Pump Eccentric	
3	F-7023	1	ECCENTRIC - Bilge Pump	
4	C-6906L2	1	KEY - Eccentric to Sleeve	
5		1	TAPER PIN -- #6 x 3 1/4 Lg.	
	X3677		BEARING ASSEM.-CAMSHAFT(& BILGE PUMP ECCENT.)	Includes
1	X3679	1	BEARING ASSEM.	
2	8C3517	1	SLEEVE - Bilge Pump Eccentric	
3	F-7023	1	ECCENTRIC - Bilge Pump	
4	C-6906L2	1	KEY - Eccentric to Sleeve	
5		1	TAPER PIN -- #6 x 3 1/4 Lg.	
	X3678		BEARING ASSEM. - CAMSHAFT (APT END)	Includes
*			1 BEARING	
1	8C3618	1	BUSHING	
2		1	OIL SEAL -- National Motor Brg. #50365	
	X3679		BEARING ASSEM. - CAMSHAFT (APT END)	Includes
*			1 BEARING	
1	8C3618	1	BUSHING	
2		1	OIL SEAL -- National Motor Brg. #50365	
	X3681		ADAPTOR ASSEM. - LUBE PRESS. PUMP.	Includes
*			1 ADAPTOR	
1	8858	2	BUSHING	
	X3682		ADAPTOR ASSEM. - LUBE PRESS. PUMP	Includes
*			1 ADAPTOR	
1	8858	2	BUSHING	
	X3683		LIFTER ASSEM. - INLET & EXHAUST VALVE	Includes
*			1 LIFTER	
1	8C3588	1	ROLLER	
2	8C3592	1	PIN - Roller	
	X3684		LIFTER ASSEM. - AIR START. VALVE	Includes
*			1 LIFTER	
1	885-E	1	ROLLER	
2	885-E	1	PIN - Roller	
	X3686		ROCKER ASSEM. - INLET VALVE	Includes
*			1 ROCKER	
1	8C3641	2	BUSHING	
2	823-E	1	ROLLER	
3	824-E	1	PIN - Roller	
4	8527A-E	1	BALL CHECK ASSEM.	

ENGINE SIZE 7 1/2 x 10 1/2 - 9 x 12
 ISSUE ASSEMBLY LIST NO. 1 AL 184

ATLAS IMPERIAL DIESEL ENGINE CO. SUB-ASSEMBLY LIST

WHEN ORDERING PARTS ALWAYS GIVE ENGINE NUMBER - PART NUMBER - NAME - OR COMPLETE DESCRIPTION AND SIZE.
 DO NOT ORDER PARTS BY REFERENCE NUMBERS
 *INDICATES PARTS NOT SOLD INDIVIDUALLY

REF. No.	PART NUMBER	No. USED	DESCRIPTION		REF. No.	PART NUMBER	No. USED	DESCRIPTION	
	X3687		ROCKER ASSEM. - EXHAUST VALVE	Includes		X3699		BRACKET ASSEM. - ENGINE CONTROL	Includes
		1	ROCKER				1	BRACKET	
1	203641	2	BOSSING		1	203684	1	FIN - Wedge Shaft Latch	
2	203-K	1	ROLLER		2	203685	1	FIN - Latch Spring Anchor	
3	204-E	1	FIN - Roller						
4	0627A-E	1	BALL CHECK ASSEM.						
	X3688		ROD ASSEM. - AIR COMPRESSOR CONNECTING	Includes		X3700		BRACKET ASSEM. - ENGINE CONTROL	Includes
		1	ROD				1	BRACKET	
1	232-456	1	BUSHING		1	203684	1	FIN - Wedge Shaft Latch	
					2	203685	1	FIN - Latch Spring Anchor	
	X3689		STRAP ASSEM. - AIR COMPRESSOR ECCENTRIC	Includes		X3701		SHAFT ASSEM. - ENGINE CONTROL LEVER	Includes
		1	STRAP (Upper Half)		1	P-7065	1	SHAFT	
		1	STRAP (Lower Half)		2	P-7077	1	HUB - Control Lever	
1	0-9200-B	4	SHIM (1/32)		3	0-9704L2	1	KEY - Hub to Shaft	
2	0-9200-D	10	SHIM (.010)						
3	0-9200-E	8	SHIM (.005)						
4	0-9212L7 3/4	2	BOLT						
5	3-2713	2	NUT						
		2	COTTER PIN -- 1/8 x 1 1/2 Lg.						
	X3690		SHOE ASSEM. - FLYWHEEL AIR BRAKE	Includes		X3702		CAM ASSEM. - AIR PILOT VALVE CONTROL	Includes
		1	SHOE				1	CAM	
1		1	LINING -- 4 Wide x 14 Lg. x 1/4 Thick - Double Stanley		1	203633	1	PIN - Spring Guide	
2			RIVETS						
	X3691		CYLINDER ASSEM. - FLYWHEEL AIR BRAKE	Includes		X3703		FOK ASSEM. - CAMSHAFT SHIFTER	Includes
1	3275	1	CYLINDER ASSEM.				1	FOK	
2	203276	1	ROD - Piston		1	0-9212L 11/16	1	PIN - Shifter Collar Guide	
3	5076	1	WASHER - Cup-Leather						
4	5078	1	CUP-LEATHER						
5	5077	1	FOLLOWER - Cup-Leather						
6		1	CASILE NUT -- 5/8-16-Hex.						
		1	COTTER PIN -- 1/8 x 1 1/4 Lg.						
7	3958	3	GUIDE - Piston Rod						
		3	CAPSCREW -- 1/2-13 x 1 1/4 Lg.						
		3	LOCKWASHER -- 1/2 SAE Reg.						
	X3692		MANIFOLD ASSEM. - AIR STARTING	Includes		X3704		COLLAR ASSEM. - CAMSHAFT SHIFTER	Includes
1	32693	6	HOUSING ASSEM. - Pilot Valve				1	COLLAR	
2	203669	6	VALVE - Pilot		1	203666	1	BUSHING	
3	32694	6	COVER ASSEM. - Valve Housing						
4	203571	6	GASKET - Cover to Housing						
		18	CAPSCREW -- 1/2-13 x 1 1/2 Lg.						
		18	LOCKWASHER -- 1/2 SAE Reg.						
5		6	RIPPLE -- 1 x 10 3/8 Lg.						
	X3693		HOUSING ASSEM. - PILOT VALVE	Includes		X3705		LEVER ASSEM. - FUEL WEDGE THRO-OUT	Includes
		1	HOUSING				1	LEVER	
1	203666	1	BUSHING		1	203681	1	BUTTON	
	X3694		COVER ASSEM. - PILOT VALVE HOUSING	Includes		X3706		LEVER ASSEM. - FUEL WEDGE THRO-OUT	Includes
			Cover & Pin (No Service Parts)				1	LEVER	
					1	203621	1	BUTTON	
	X3695		VALVE ASSEM. - AIR STARTING(AUTOMATIC)	Includes		X3708		RAIL ASSEM. - FUEL	Includes
1	32696	1	HOUSING ASSEM.				1	RAIL - Fuel	
2	203664	1	VALVE		1	1206-E1	7	BODY - Isolating Valve	
3	20170-P2 1/2	2	RING - Piston		2	1206-E	7	SEAT - Isolating Valve	
4	203660	1	SPRING - Valve		3	1206D-E	7	PLUG - Isolating Valve	
5	203662	1	COVER - Valve Housing Top		4	1206-C21	7	STEM - Isolating Valve	
6	203663	1	GASKET - Cover to Housing		5	866-E	7	GLAND - Packing	
		4	CAPSCREW -- 1/2-13 x 1 1/2 Lg.		6	1206-C3	7	NUT - Gland	
		4	LOCKWASHER -- 1/2 SAE Reg.		7		21	RING - Packing -- 1/4 I.D. x 1/2 O.D. x 1/4 Th. -- Garlock #333	
	X3696		HOUSING ASSEM. - AIR STARTING VALVE(AUTOMATIC)	Includes		X3710		GLAND ASSEM. - BILGE PUMP PACKING	Includes
		1	HOUSING				1	GLAND	
1	203660	1	SLEEVE		1	203606L7	2	STUD	
	X3698		CYLINDER ASSEM. - AIR STARTING	Includes		X3711		RAIL ASSEM. - FUEL	Includes
1	W-2219	1	CYLINDER				1	TUBE - Fuel	
2	P-7054	1	BASE - Cylinder (End Cover)		1	1206-E1	4	BODY - Isolating Valve	
3	203608	1	GASKET - Base to Cylinder		2	1206D-E	4	SEAT - Isolating Valve	
		3	CAPSCREW -- 1/2-13 x 2 1/4 Lg.		3	1206D-E	4	PLUG - Isolating Valve	
		3	LOCKWASHER -- 1/2 SAE Reg.		4	1206-C21	4	STEM - Isolating Valve	
4	203610	1	RING - Piston Rod Cup-Seal		5	866-E	4	GLAND - Packing	
5	20172-F	1	CUP-SEAL - Piston Rod		6	1206-C3	4	NUT - Packing Gland	
6	P-7063	1	HEAD - Cyl. - (End Cover)		7		12	PACKING RING -- 1/4 I.D. x 1/2 O.D. x 1/4 Th. -- Garlock #333	
7	203609	1	GASKET - Head to Cyl.						
		3	CAPSCREW -- 1/2-13 x 1 3/4 Lg.						
		3	LOCKWASHER -- 1/2 SAE Reg.						
8	P-7062	1	ROD - Piston						
9	203612	1	PISTON						
10	20173-F	1	CUP-SEAL - Piston						
11	203613	1	FOLLOWER - Upper Cup-Seal						
12	203611	1	WASHER - Cup-Seal Spacer						
13	4953	2	WASHER - Piston Bumper						
14	4952	1	WASHER - Bumper Washer Adaptor						
15		1	NUT -- 1/2-13-Hex.						
16		1	TAPER PIN -- #0 x 1 Lg.						
17	203675	1	PLUNGER - Piston Lock						
18	203676	1	SPRING - Piston Lock Plunger						
		1	PIPE PLUG -- 3/8 Std.						
		2	PIPE PLUG -- 1/8 Std.						
	X3699		BRACKET ASSEM. - ENGINE CONTROL	Includes		X3713		CYLINDER ASSEM. - AIR STARTING	Includes
		1	BRACKET		1	W-2232	1	CYLINDER	
1	203684	1	FIN - Wedge Shaft Latch		2	P-7090	1	BASE - Cylinder (End Cover)	
2	203685	1	FIN - Latch Spring Anchor		3	203717	1	GASKET - Base to Cyl.	
							3	CAPSCREW -- 1/2-13 x 2 1/4 Lg.	
							3	LOCKWASHER -- 1/2 SAE Reg.	
					4	203610	1	RING - Piston Rod Cup-Seal	
					5	20172-F	1	CUP-SEAL - Piston Rod	
					6	P-7053	1	HEAD - Cyl. (End Cover)	
					7	203609	1	GASKET - Head to Cyl.	
							3	CAPSCREW -- 1/2-13 x 1 3/4 Lg.	
							3	LOCKWASHER -- 1/2 SAE Reg.	
					8	P-7062	1	ROD - Piston	
					9	203699	1	PISTON	
					10	20177-F	2	CUP-SEAL - Piston	
					11	203698	1	FOLLOWER - Upper Cup-Seal	
					12	203700	1	WASHER - Cup-Seal Spacer	
					13	4953	2	WASHER - Piston Bumper	
					14	4952	1	WASHER - Bumper Washer Adaptor	
					15		1	NUT -- 1/2-13-Hex.	
					16		1	TAPER PIN -- #0 x 1 Lg.	
					17	203675	1	PLUNGER - Piston Lock	
					18	203676	1	SPRING - Piston Lock Plunger	
							1	PIPE PLUG -- 3/8 Std.	
							2	PIPE PLUG -- 1/8 Std.	

ATLAS IMPERIAL DIESEL ENGINE CO. SUB-ASSEMBLY LIST

WHEN ORDERING PARTS ALWAYS GIVE ENGINE NUMBER - PART NUMBER - NAME - OR COMPLETE DESCRIPTION AND SIZE.
DO NOT ORDER PARTS BY REFERENCE NUMBERS
*INDICATES PARTS NOT SOLD INDIVIDUALLY

ISSUE ASSEMBLY LIST NO. AL 185
ENGINE SIZE 7 1/2 x 10 1/2 - 9 1/2

REF. No.	PART NUMBER	No. USED	DESCRIPTION	
	X3714		GEAR ASSEM. - INTERMEDIATE	Includes
*		1	GEAR	
1	664B-A32	1	BUSHING	
	X3718		BEARING ASSEM. - THRUST	Includes
*		1	BEARING	
*		1	CAP - Bearing	
*		2	PIPE - Oil (Cast in place)	
1	2C3737	2	GASKET (Cap to Brg.)	
*		2	CAPSCREW -- 3/4-10 x 3 3/4 Lg.	
*		2	LOCKWASHER -- 3/4 S&S Reg.	
2	C-6629L3	2	PIN - Dowel (Cap to Brg.)	
*		2	PIPE PLUG -- 1/2 Std.	
3	P-7101	1	COVER - Top	
4	P-7100	1	GASKET - Cover to Bearing Cap	
*		6	CAPSCREW -- 1/2-13 x 1 1/2 Lg.	
*		6	LOCKWASHER -- 1/2 S&S Reg.	
5	P-7102	1	COVER - Thrust Brg. Bottom	
6	2C3738	1	GASKET - Cover to Bearing	
*		10	CAPSCREW -- 1/2-13 x 1 1/2 Lg.	
*		10	LOCKWASHER -- 1/2 S&S Reg.	
*		1	PIPE PLUG -- 1/2 Std.	
7	2654	1	PIPE - Water (Lower Brg. to Cap)	
8	C-3388	1	GASKET - Water Pipe to Bearing	
*		2	CAPSCREW -- 1/2-13 x 2 1/4 Lg.	
*		2	LOCKWASHER -- 1/2 S&S Reg.	
9	2C2796L2	2	STUD - Packing Gland	
10	2C3718	4	RING - Packing Gland Seal (Halves)	
11		4	PACKING -- 3/8 Sq. x 15 Lg. - Green Tread Co. "PALCO" Plated Packing	
12	X3719	2	GLAND ASSEM. - Packing	
*		2	NUT -- 3/8-16-Hex.	
*		2	HALF NUT -- 3/8-16-Hex.	
	X3719		GLAND ASSEM. - THRUST BRG. PACKING	Includes
			Packing Gland (Halves) (No Service Parts)	
	X3720		BAND ASSEM. - PROPELLER BRAKE	Includes
*		1	BAND	
*		2	RIVETS -- 1/4 Dia. x 1/4 Lg. - Fnd. Hl.	
*		1	PLATE - Reinforcing	
*		2	RIVETS -- 1/4 Dia. x 3/4 Lg. - Fnd. Hl.	
1	2C3740	1	LINING - Brake Band	
2		21	RIVETS -- 3/16 x 5/16 Lg. - Tubular	
	X3721		PLUNGER ASSEM. - PROPELLER BRAKE	Includes
*		1	PLUNGER	
1	S-2388	1	ROLLER	
2	S-2390	1	PIN - Roller	
3	S-2389	1	STUD - Brake Band	
	X3722		ROD ASSEM. - PROPELLER BRAKE CONTROL	Includes
			Control Rod & Cam (No Service Parts)	
	X3723		BASE ASSEMBLY	Includes
*		1	BASE	
1	S-2918	8	PIN - Crank. Brg. Shell Dowel	
2	C-9879	8	CONNECTOR - Oil Tube	
3	C-2112L5 3/4	16	STUD - Brg. Cap	
4	727-B23	23	STUD - Base, Centerframe & Cylinder	
5	729-B23	1	STUD - Base & Centerframe (Fwd. End - Large)	
6	C-2012L18 1/4	2	STUD - Base & Centerframe (Aft End - Small)	
7	713-B	7	CAP - Bearing	
8	2C3482	1	CAP - Bearing (Aft End)	
9	S-2713	16	NUT - Bearing Cap	
*		16	COTTER PIN -- 1/8 x 1 1/2 Lg.	
*		2	PIPE PLUG -- 1 Std. - C't's'k. Hl.	
*		2	PIPE PLUG -- 1/2 Std.	
	X3725		CRANKSHAFT ASSEMBLY	Includes
*		1	CRANKSHAFT	
1	2C3483	1	GEAR	
2	2C289L1	2	PIN - Eccentric & Sprocket Drive	
3	C-8208	1	PIN - Eccentric Dowel	
4	2C3781	1	RING - Oil Thrower (Fwd. End)	
	X3726		RAIL ASSEM. - FUEL	Includes
*		1	TUBE - Fuel	
1	1206-E1	5	BODY - Isolating Valve	
2	1206-C-2	5	SEAT - Isolating Valve	
3	1206-E	5	PLUG - Isolating Valve	
4	1206-C31	5	STEM - Isolating Valve	
5	864-E	5	GLAND - Packing	
6	1206-C5	5	NUT - Packing Gland	
7		16	PACKING RING -- 1/4 I.D. x 1/2 O.D. x 1/4 Th. Garlock #333	

REF. No.	PART NUMBER	No. USED	DESCRIPTION	
	X3735		VALVE ASSEM. - FUEL CUT-OUT CONTROL	Includes
*		1	BODY - Valve	
*		5	PIPE PLUG -- 1/8 Std.	
*		1	PLUNGER - Valve	
1	2C3845	1	SPRING - Plunger	
2	2C3842	1	PLUNGER - Valve Body End (Spring End)	
3	2C3841	1	PLUG - Valve Body End	
4	2C3844	2	GASKET - Plug to Body	
	X3739		STUD ASSEM. - ENGINE CONTROL LEVER RETAINING	Includes
*		1	STUD	
1	2C3844 S/B	1	PIN	
	X3743		LATCH ASSEM. - WEDGE HOLD-OUT	Includes
*		1	LATCH	
1	2C3850	1	PLUNGER	
2	2C3852	1	PLUG	
3	C-8116	1	GASKET - Plug to Latch	
*		1	PIPE PLUG -- 1/8 Std.	
	X3833		IMPELLER & SHAFT ASSEM. - 1 1/2" CENTRIFUGAL PUMP	Includes
*		1	IMPELLER	
1	2C4124	1	SHAFT	
1	C-821	1	PIN - Impeller to Shaft Lock	
	X3834		PUMP ASSEM. - 1 1/4" CENTRIFUGAL	Includes
1	2C370-E1	1	BODY ASSEM.	
2	371-E	1	COVER - Suction	
3	3710-E	1	GASKET - Cover	
4	X3833	12	MACHINE SCREW -- 1/4-20 x 3/8 Lg. - Fnd. Hl.	
5		1	IMPELLER & SHAFT ASSEM.	
6		1	PACKING -- 3/8 Sq. x 12 Lg. - (Flax)	
7	372-E	1	GLAND - Packing	
8		4	NUT -- 7/16-14-Hex.	
9	X68	1	CUP ASSEM. - Grease	
10	381-PB4	1	BEARING - Steady	
11		2	CAPSCREW -- 3/8-16 x 3/4 Lg.	
12		2	CAPSCREW -- 3/8-16 x 1 Lg.	
13		1	CAPSCREW -- 1/2-13 x 2 Lg.	
14	386-PB41	1	HOUSING - Ball Bearing	
15	C-9069-P	1	BALL BEARING	
16	C-9070-P	1	ADAPTOR - Ball Bearing	
17	386a-PB41	1	RETAINER - Ball Bearing	
18		1	GREASE CUP -- 1/8 - Lunkenheimer - "Guard #00"	
19	785-E	1	FLANGE - Suction Pipe	
20	S-2334	1	GASKET - Flange	
21	785-E	2	CAPSCREW -- 1/2-13 x 1 Lg.	
22	S-2334	1	FLANGE - Pump Discharge	
23	785-E	1	GASKET - Flange	
24	S-2334	2	CAPSCREW -- 1/2-13 x 1 Lg.	
	X3838		SEAL ASSEM. - CRANKSHAFT OIL	Includes
*		2	OIL SEAL	
1	2C4127	2	CAPSCREW -- 3/8-16 x 1 1/2 Lg.	
		2	NUT -- 3/8-16-Hex.	
		2	LOCKWASHER -- 3/8 S&S Reg.	
		2	GASKET	
	X3839		BASE ASSEMBLY	Includes
*		1	BASE	
1	S-2918	4	PIPE - Crank. Brg. Shell Dowel	
2	C-2112L5 3/4	16	STUD - Crank. Brg. Cap	
3	727-B23	16	STUD - Base, Centerframe & Cylinder	
4	729-B23	1	STUD - Base & Centerframe	
5	731-B23	2	STUD - Base & Centerframe (End)	
6	X2061	1	MANIFOLD ASSEM. - Lubr Oil	
7	C-7865	2	PIPE PLUG -- 3/8 Std.	
8	C-2406L 1/2	1	PIPE PLUG -- 1/2 Std. - C't's'k. Hl.	
9	2C28543	4	CLAMP - Manifold to Base	
10	C-3682	8	CAPSCREW - Manifold Clamp to Base	
11	P-5194	5	TUBE - Manifold to Crank. Brg. Oil	
12	713-B	5	WASHER - Crank. Brg. Oil Tube	
13	S-2713	1	CAP - Crankshaft Bearing (End)	
14		4	CAP - Crankshaft Bearing	
15		18	NUT - Crankshaft Bearing Cap	
16		18	COTTER PIN -- 1/8 x 1 1/2 Lg.	
	X3842		CRANK ASSEM. - FUEL PUMP	Includes
*		1	CRANK - Fuel Pump	
1	2C4132	1	SHAFT - Tachometer Drive	
		1	SETSCREW -- 1/4-20 x 3/8 Lg. - HD. Cap Pt.	

ENGINE SIZE 7 1/2 x 10 1/2
 ISSUE #2
 ASSEMBLY LIST NO. AL 186

ATLAS IMPERIAL DIESEL ENGINE CO. SUB-ASSEMBLY LIST

WHEN ORDERING PARTS ALWAYS GIVE ENGINE NUMBER-PART NUMBER-NAME-OR COMPLETE DESCRIPTION AND SIZE.
 DO NOT ORDER PARTS BY REFERENCE NUMBERS
 *INDICATES PARTS NOT SOLD INDIVIDUALLY

REF. No.	PART NUMBER	QTY. USED	DESCRIPTION	
	X3873		THRUST BEARING ASSEMBLY	Includes
		1	BEARING	
		1	CAP	
		3	PIPE PLUG -- 1 1/4 Std.	
		1	PIPE PLUG -- 1 1/4 Std. - C't's'k. Hd.	
		2	REDUCING BUSHING -- 1 1/4 x 1/4 Std.	
1	C-7816-A	2	SHIM - (1/16)	
1	C-7816-B	2	SHIM - (1/32)	
1	C-7816-C	4	SHIM - (1/64)	
		4	CAPSCREW -- 3/4-10-NC x 2 Lg.	
2	C-669PL2	2	PIN - Cap to Bearing Dowel	
3	F-4306	2	PIPS - Cap to Bearing Water By-Pass	
4	C-3287	2	GASKET - Water By-Pass Pipe	
		4	CAPSCREW -- 1/2-12-NC x 2 Lg.	
	X3908		MANIFOLD ASSEM. - AIR INLET	Includes
			Manifold & Flanges (No Service Parts)	
	X3913		BASE ASSEMBLY	Includes
		1	BASE	
		4	PIPE PLUG -- 1 1/2 Std.	
1	S-2918	4	PIN - Crank. Brg. Shell Dowel	
2	C-8118L5 3/4	10	STUD - Crank. Brg. Cap	
3	787-883	11	STUD - Base, Centerframe & Cylinder	
4	789-883	1	STUD - Base & Centerframe	
5	781-883	2	STUD - Base & Centerframe (End)	
6	X2060	1	MANIFOLD ASSEM. - Lube Oil	
		2	PIPE PLUG -- 3/8 Std.	
		1	PIPE PLUG -- 1/2 Std. - C't's'k. Hd.	
7	C-7885	3	CLAMP - Manifold to Base	
8	C-2406L 1/2	6	CAPSCREW - Manifold Clamp to Base	
9	202643	4	TUBE - Manifold to Crank. Brg. Oil	
10	C-3682	4	WASHER - Crank. Brg. Oil Tube	
11	F-5194	1	CAP - Crankshaft Bearing (Hnd)	
12	713-B	3	CAP - Crankshaft Bearing	
13	S-2712	10	NUT - Crankshaft Bearing Cap	
		10	COTTER PIN -- 1/8 x 1 1/2 Lg.	
	X3920		ADAPTOR ASSEM. - LUBE PRESS. PUMP	Includes
		1	ADAPTOR	
1	5858	2	BUSHING	
	X3921		ADAPTOR ASSEM. - LUBE PRESS. PUMP	Includes
		1	ADAPTOR	
1	5858	2	BUSHING	
	X3950		PUSH-ROD ASSEM. - SPRAY VALVE	Includes
			Push-Rod Tube, Socket & Button (No Service Parts)	
	X3951		CENTERFRAME ASSEMBLY	Includes
		1	CENTERFRAME	
		1	PIPE PLUG -- 1/2 Std. - C't's'k. Hd.	
1	C-5680L9 1/4	1	STUD - Centerframe to Cylinder	
2	846A-883	4	STUD - Fuel Pump Housing	
3	C-5310L3	4	STUD - Air Compressor Cylinder	
4	S-1983	7	PIN - Centerframe Door Dowel	

REF. No.	PART NUMBER	QTY. USED	DESCRIPTION	
	X5087		VALVE & GAGE ASSEM.-PUMP SUCTION & DISCHARGE	Includes
1	S-577	1	GAGE	
2	S-579	1	VALVE - Suction	
3	S-681	1	SPRING - Suction Valve	
4	S-683	1	WASHER - Suction Valve Spring Retainer	
		1	COTTER PIN -- 1/16 x 1 1/2 Lg.	
6	S-590	2	CAP - Suction Valve	
7	811-B	1	VALVE - Discharge	
	X5227		HANDLE ASSEM. - GOVERNOR SPEED CONTROL	Includes
1	1117-B	1	HANDLE (Upper Sect.)	
2	S-2910	1	HANDLE (Lower Sect.)	
3	1849-B	1	SCREW - Handle	
4		1	WALP NUT -- 1/4-20-Hex.	
4	1118-EI	1	PAWL	
5		1	TAPER PIN (Pawl Retain.)--#1 x 1 Lg.	
6	1124-E	1	SPRING - Pawl	
7	1125-E	1	PLUG - Spring Retainer	
	X5353		DOCK ASSEM. - H.P. FUEL PUMP	Includes
			Pump Body & Plunger (No Service Parts)	

INSTRUCTION BOOK
and
REPAIR PARTS LIST

Model 50

MADISON-KIPP LUBRICATOR

MADISON-KIPP CORPORATION

Madison, Wisconsin, U. S. A.

The MODEL 50 pumping unit illustrated in Figure 1 embodies a mechanical motion so ingenious as to deserve your special attention. The driving eccentric imparts to both forcing and metering plungers a reciprocating movement for pumping and an oscillating movement for valving. The angle of the eccentric ring groove is 27°. When the eccentric makes a complete revolution, the plungers make a total swing of 54°. The reciprocating movement or lift is .212". Oil intake and outlet ports register with grooves in the plungers as they travel their cycle.

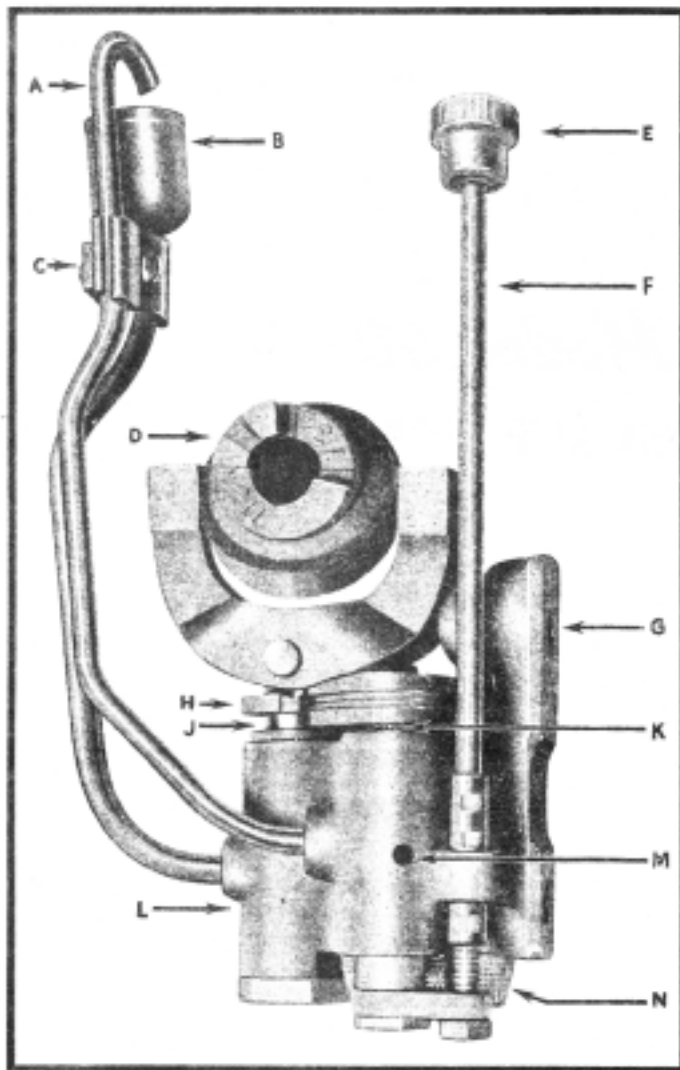

A Sight Feed Tube which shows the amount of oil in drops according to the oil delivery adjustment setting.

B Sight Feed Oil Cup.

C Tube Clamps tying the tubes "A" and "B" together.

D Eccentric to impart the reciprocating and oscillating movement to the plungers (See first paragraph above).

E Adjusting Button to regulate the amount of oil to be delivered per feed impulse.

F Adjusting Spindle.

G Oil Outlet from pumping unit.

H Gear for oscillating and lifting metering plunger in unison with forcing plunger.

J Plunger which forces the measured quantities of oil to the feed outlet.

K Metering Plunger which delivers oil to the sight feed cup.

L Body of pumping unit.

M By-Pass Opening—oil not delivered to the sight feed cup is by-passed back to the reservoir.

N Fine Strainer located at oil inlet of pumping unit.

Figure 1

INSTRUCTIONS FOR ATTACHING, OPERATING AND CARE OF MADISON-KIPP LUBRICATORS.

Madison-Kipp Model 50 Lubricators are built on one standard design, of any required size and number of feed outlets, and are applied universally to all types of steam, oil, and gas engines, steam pumps, air compressors, steam hammers, shovels, dredges and cranes, marine engines, steering engines, drilling engines, agricultural tractors, grain separators, machine tools, and special types of machinery.

The Sight Feed type is built with a visible feed and an individual fine adjustment for each pumping unit. The Blind Feed type is designed for service where fine adjustment and visible feed are not necessary. It can be adjusted, however, by means of employing different lengths on the ratchet arm.

Madison-Kipp Lubricators are built on the Kipp Valveless principle, which permits the pumping and forcing of oil without the use of ball and spring valves.

ATTACHING

The lubricator should be bolted down, using lock washers to prevent bolts from working loose. Try to avoid offset bends in the driving rod.

The driving arm should be clamped on the lubricator shaft so as to place the driving pawl located inside the lubricator in the center of the space available for the stroke. If possible, turn machine over by hand to check stroke and clearance.

The standard lubricator is provided with a 44-tooth ratchet wheel and would require 44 strokes to complete one revolution of the lubricator if connected to engage with one tooth of the ratchet per stroke. The recommended speed varies from four to twenty revolutions per minute, depending on the type and size of machine to be lubricated.

Oil Leads

Lubricators can be furnished with connections for either $\frac{1}{4}$ " O. D. copper or brass tubing, or for $\frac{1}{8}$ " or $\frac{3}{8}$ " iron pipe. Where many turns and bends are necessary, the copper or brass tubing is preferable. The tubing or pipe should be clean, ends free from burrs and cut to a length which will allow the connections between the lubricator and point to be lubricated to be as direct as possible. Care should be taken when bending tubing to avoid flattening, which would restrict the flow of oil. All joints should be tight, and tubing or pipe should be anchored securely to machine to avoid vibration. Where possible, arrange tubing to prevent exposure to the extreme cold. In making the joint, let the tubing extend through the ferrule into the connection at least $\frac{1}{8}$ ".

OPERATION AND ADJUSTMENT

Fill the lubricator with *clean* oil and turn hand crank until each of the oil leads are filled with oil. At this time make an inspection of all the connections to see that no leaks occur.

Adjustment or regulation of the quantity of oil to be delivered for each revolution of the unit is accomplished by turning the adjusting button, located on the cover (Part C-880-A). Turning to the right (clockwise) decreases, and to the left (counter-clockwise) increases the amount of oil being forced to the point to be lubricated. Observation can be made through the transparent hood to see the amount delivered by each feed. A very close adjustment may be had. Turning the lubricator by means of the hand crank when making adjustment is recommended. When lubricator is first applied, it is recommended as a safe practice to leave lubricator set for maximum delivery of oil, cutting it down gradually with care if an oversupply is noted at the points to be lubricated.

CARE OF LUBRICATOR

The Madison-Kipp pumping unit is made of very accurately machined parts which function coördinately, contains no troublesome check valves and springs and for this reason requires no attention after final feed adjustments have been made, other than the care necessary to keep dirt out of the lubricator.

Field operators, while perhaps not intentionally careless, often make no provision for keeping oil containers, funnels, etc., free from dust and dirt. As foreign matter so collected is likely to find its way into the lubricator tank, it is recommended as standard practice to drain the oil out of the lubricator and clean out the reservoir with kerosene every thirty to ninety days, depending on usage. The following are our suggestions for attention at regular intervals:
Use only clean oil.

Keep the lubricator full of oil.

See that all connections are tight.

See that the oil pipes are supported where excessive vibration is developed. See that the lubricator is securely bolted down.

Inspect lubricator to see that filler cup strainer has not been removed. This part should be taken out for cleaning purposes only.

Keep the sight feed hood clean.

Cleaning

1. To clean out reservoir or repair lubricator, it is necessary to remove lubricator from the engine by unscrewing the oil tube connections, loosening the driving arm and unscrewing the bolts at the bolting brackets.

2. Remove cover by first unscrewing all cover screws and then lifting the cover off with the aid of a screw driver used as a pry.

3. Remove drain plug and drain oil from lubricator reservoir.

The lubricator can then be thoroughly washed out with kerosene. Do not operate the lubricator any more than necessary while washing and see that all kerosene is removed before filling with fresh oil.

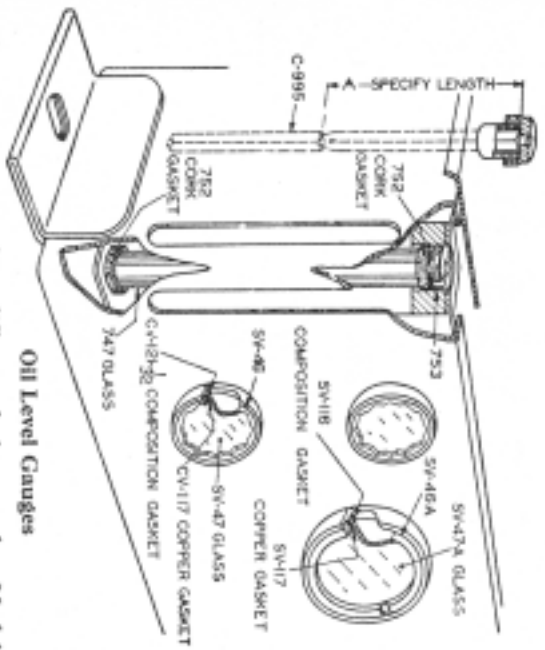
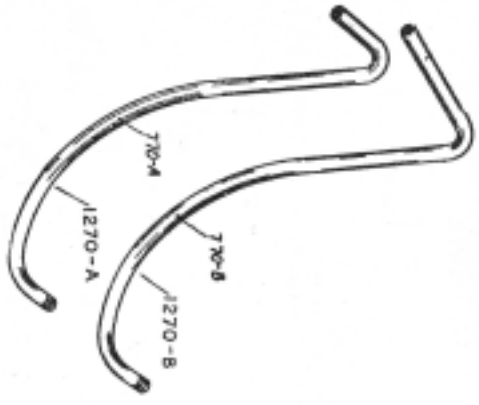

Illustration shows four different designs used on Model 50 Lubricator. When ordering specify symbol numbers of parts required.

Oil Level Gauges

(Fig. 19.)



Side Ratchet and Rotary Drive Bearing Oiling Tubes
Tubes 770 A & B are for right hand drive lubricators. Tubes 1270 A & B are for left hand drive lubricators—see parts description for tube necessary for different types of drives. (Fig. 26.)

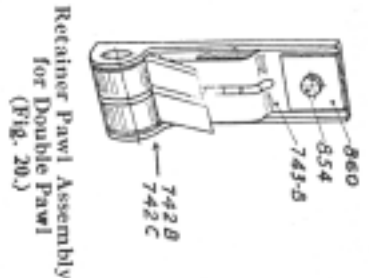

Retainer Pawl Assembly for Double Pawl
(Fig. 20.)

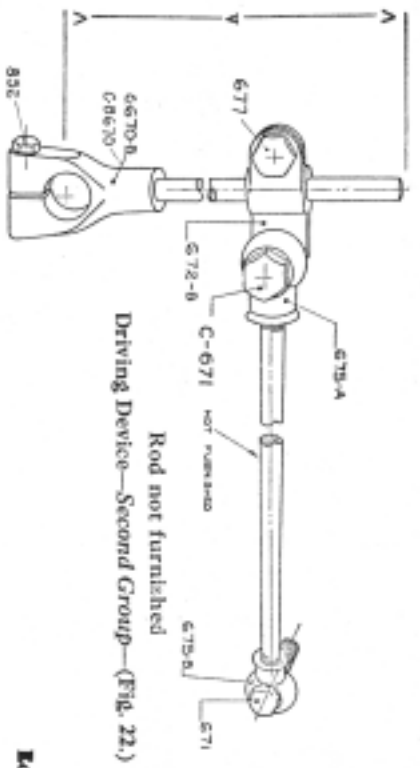

Driving Device—Second Group—(Fig. 22.)

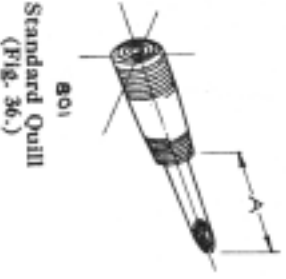

Standard Quill
(Fig. 36.)



Nipple
(Fig. 37.)

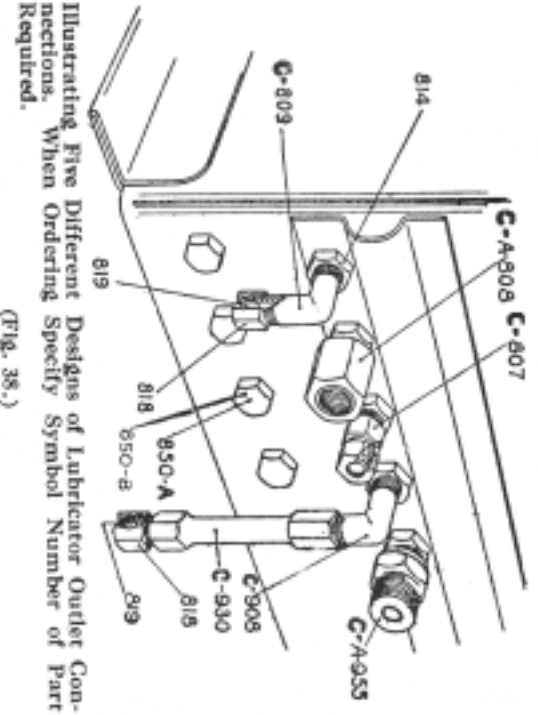

Illustrating Five Different Designs of Lubricator Outlet Connections. When Ordering Specify Symbol Number of Part Required. (Fig. 38.)

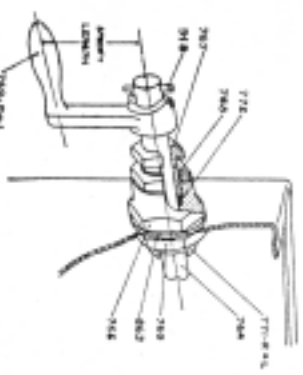

Eccentric Shaft Bearing Assembly. Left hand as illustrated.
(Fig. 45.)



Hand Crank Shield
(Fig. 47.)

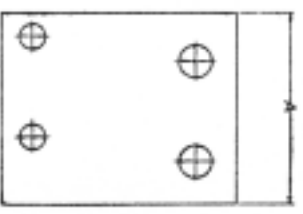

Unit Gasket
(Fig. 46.)



Pipe Size Bushing
(Fig. 39.)



Compression Nut
(Fig. 40.)

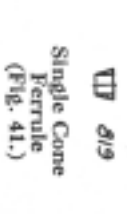

Single Cone Ferrule
(Fig. 41.)

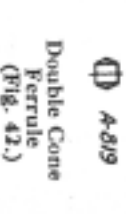

Double Cone Ferrule
(Fig. 42.)

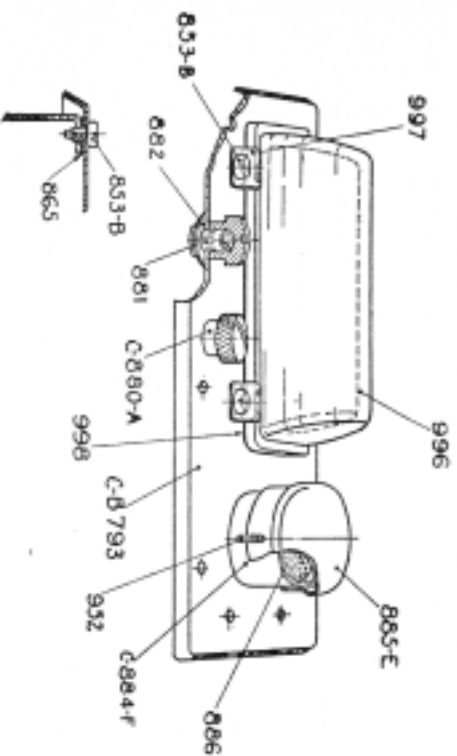

Slight Feed Lubricator Cover. Symbol C-B793. Having Glass Hood
L. H. as illustrated
(Fig. 7.)

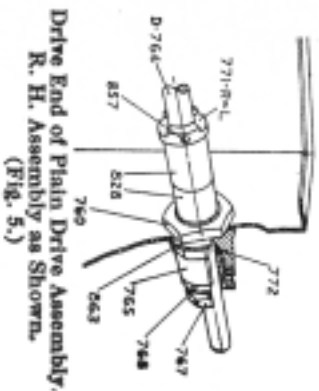

Drive End of Plain Drive Assembly.
R. H. Assembly as Shown.
(Fig. 5.)

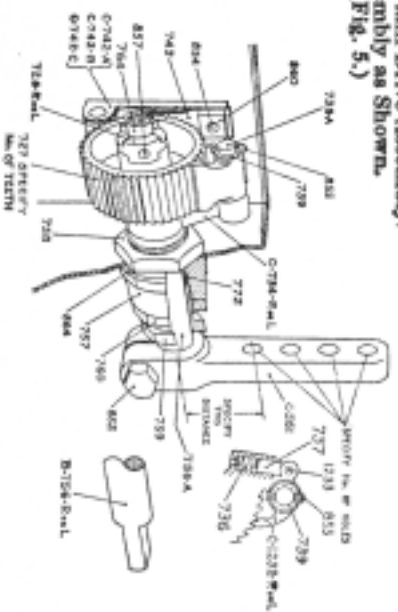

End ratchet drive assembly.
be on opposite end of reservoir.

Right hand assembly is shown, left hand would
(Fig. 10.)

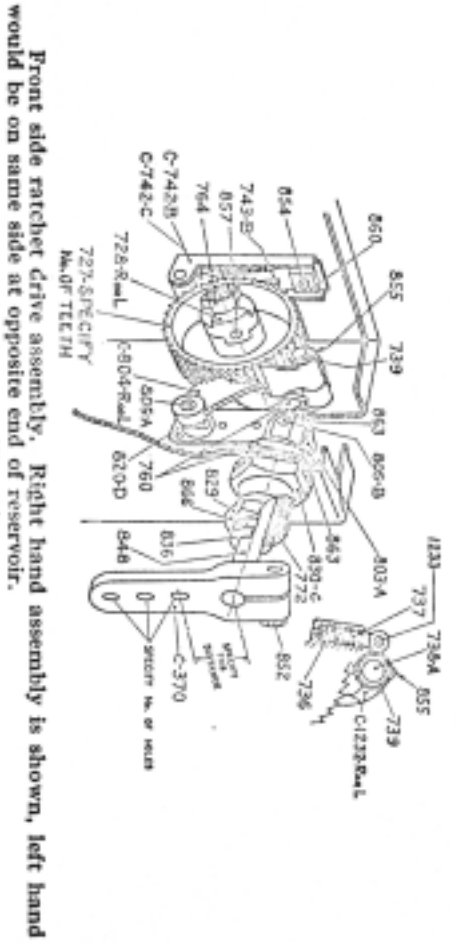

Front side ratchet drive assembly. Right hand assembly is shown, left hand
would be on same side at opposite end of reservoir.
(Fig. 9.)

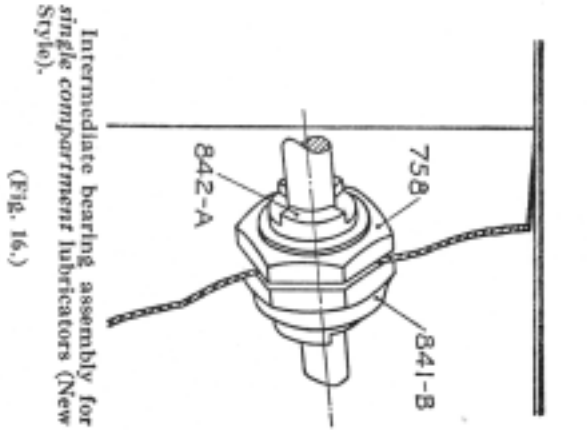

Intermediate bearing assembly for
single compartment lubricators (New
Style).
(Fig. 16.)

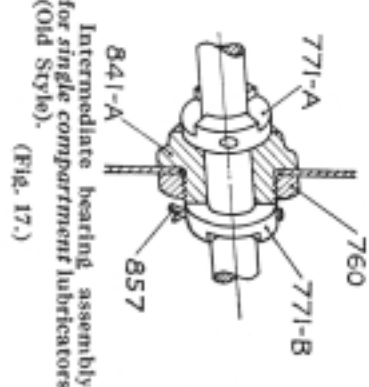

Intermediate bearing assembly
for single compartment lubricators
(Old Style).
(Fig. 17.)

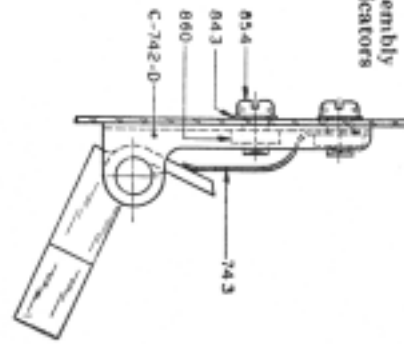

Weighted Retainer Pawl
Assembly.
(Fig. 18.)

Directions for Ordering Repair Parts

All parts of the Model 50 Lubricator are clearly illustrated and numbered on the preceding pages.

Locate the part wanted in the illustrations to obtain the part number. Names and prices are given on the pages following illustrations.

BE SURE TO GIVE PART NUMBER, NAME AND OTHER INFORMATION ASKED FOR UNDER THE NUMBER OF THE PART WANTED

Parts are furnished only as listed. Pumping unit and plungers are never sold separately.

Prices are subject to change without notice.

Sales, use, or other taxes imposed on these products shall be borne by purchaser.

SYMBOL	NAME	PRICE
CV-16	Union Nut	.30
SV-46	Glass Clamp Screw for SV-47	.25
SV-46A	Glass Clamp Screw for SV-47-A	.40
SV-47	Gauge Glass Disc 1 1/4" Diameter	.20
SV-47-A	Gauge Glass Disc 1 1/2" Diameter	.25
SV-116	Composition Gasket for SV-47-A	.10
SV-117	Copper Gasket for SV-47-A	.15
CV-117	Copper Gasket for SV-47	.10
CV-121 1/2	Composition Gasket for SV-47	.05
CV-233	Terminal Check valve plug	\$.20
C-370	Drive Arm complete with 852 screw. Specify distance indicated on cut and number of holes	1.20
C-561	Drive Arm complete with 852 screw. Specify distance as indicated on cut and number of holes	1.00
C-561-D	Drive Arm weight, complete with set screw	.75
C-575-A	Blind Feed Pumping Unit complete as illustrated. Plunger and barrel never furnished separately	6.00
580-B	Unit Test Tube	.25
581	Unit Test Tube Spout	.15
582-A	Unit Test Tube Spout Screw	.10
C-B-670	Adjustable Drive Arm with 852 screw for 1/2" Dia. shaft. Specify Dimension "A"	2.00
C-670-B	Adjustable Drive Arm with 852 screw for 3/4" Shaft. Specify Dimension "A"	2.25
671	Adjustable Drive Arm Bolt	.20
C-671	Adjustable Drive Arm Bolt with nut and washer	.30
672-B	Sliding Head	1.10
675-A	Adjustable Drive Arm Swivel	.50
675-B	Adjustable Drive Arm Swivel	.50
677	3/8" x 3/4" Hex Head Cap Screw for 672-B	.10

SYMBOL	NAME	PRICE
C-678	Connecting Rod Clamp complete with set screw	1.50
700	Sight and Blind Feed Lubricator Tanks (Not illustrated)	
	See footnote before ordering:	
	1 and 2 feed sizes	\$8.00
	3 and 4 feed sizes	9.00
	5 and 6 feed sizes	10.00
	7 and 8 feed sizes	12.00
	9 and 10 feed sizes	14.00
	11 and 12 feed sizes	16.00
	Prices of larger sizes on application.	
C-701	Pumping Unit for Sight Feed. Complete as illustrated	7.50
C-A-701-R	Pumping Unit same as C-701 except has 770 Drive bearing oiling tube. For right hand drive lubricators	7.75
C-A-701-L	Pumping Unit same as C-701 except has 1270 Drive bearing oiling tube. For left hand drive lubricators	7.75
C-712-A	Eccentric for pumping unit (Consisting of 2 pieces)	.75
C-718-B	Eccentric Strap Yoke Assembly less C-712 eccentric	1.00
720	Gasket. Specify Dimension "A"	.10
723-A	Eccentric Yoke Knuckle Pin	.05
724	Hand Crank Pin Shield	.20
725	Hand Crank Pin for use with 724	.05
726	1/2" Lock washer for 724	.05
727	Ratchet wheel. Specify number of teeth	1.50
728-R or L	Drive Collar. Specify whether lubricator has right or left hand drive. Right hand is illustrated	.50
C-734-R or L	Paul Carrier Arm complete with 756-A and 738-A stud. Right hand is illustrated	1.00
736	Pawl Plunger Spring	.10
737	Pawl Plunger	.10
738-A	Stud. Furnished only with C-734 R. or L. and C-804 R. or L. Pawl carrier arms	
738-B	Stud. Furnished only with C-806 R. or L. Pawl Carrier Arm	
739	Pawl Stud Washer	.05
C-742-A	Retainer pawl assembly complete with stud and single pawl	1.00
C-742-B	Retainer Pawl Assembly complete with stud and two paws for 44 and 88 tooth ratchet wheel	1.00
C-742-C	Retainer Pawl Assembly complete with stud and two paws for 66 tooth ratchet wheel	1.00
C-742-D	Retainer Pawl Assembly with weighted pawl	1.50
743	Spring for single pawl retainer	.10

SYMBOL	NAME	PRICE	SYMBOL	NAME	PRICE
743-B	Spring for double pawl retainer	.20	C-789-A	Adjusting Spindle with 792, 792-A and 883	.20
747	Tubular Gauge Glass	.30	C-790	Tube Clamp for single unit, complete with bolt and nut	.10
752	Gasket upper and lower for 747 gauge glass	.05	C-790-A	Tube clamp for binding together more than one unit. Specify how many. Complete with nuts and bolts	.40
753	Plug screw for 747 gauge glass	.05	791	Plug for adjusting sleeve	.10
756-A	Drive Shaft, Furnished only with C-734 R. or L.		792	Adjusting spindle collar (Lower)	.05
B-756	Drive Shaft with milled end furnished only with C-734 R. or L. (Specify milled end shaft if required)		792-A	Adjusting spindle collar (Upper)	.05
757	Drive Shaft Bearing	.85	C-A-793-R. or L.	Sight Feed lubricator covers complete as illustrated.	
758	Bearing lock nut	.20	C-B-793-R. or L.	Specify whether for right or left hand drive lubricator, length of lubricator tank, if for single or double compartment specify the number of feeds in each compartment. If single compartment of over six feeds specify number of intermediate bearings or number of sight feed hoods and also number of screw holes in cover.	
759	Bearing Gland	.25		NOTE: The covers as illustrated show both old (C-A-793) and new (C-B-793) Covers. These covers are not interchangeable and therefore be sure to specify correct number of cover wanted as well as all information requested.	
760	Bearing and Gland Lock Nut	.20			
761	Washer for 762 and C-981	.05			
C-762	Stud for 763 with nut, washers and cotter key	.30			
763	Strap and connection complete. Specify Dimension "A"	.85			
764	Eccentric Shaft. Specify length and if for hand crank shield	1.00			
D-764	Eccentric Shaft for plain drive lubricator. Specify length and if for hand crank shield. Illustrated Figure 5	1.00			
765	Hand Crank Bearing	.70			
766	Spacing Washer $\frac{3}{4}$ " O.D. x $\frac{1}{4}$ " I.D. x $\frac{1}{8}$ " thick (Not illustrated)	.05			
767	Eccentric Shaft Bearing Gland	.20			
768	Eccentric Shaft bearing gland lock nut	.10			
769-R. or L.	Hand Crank. Specify length of crank and whether for right or left hand drive lubricators	.40			
770-A	Drive Bearing Oiling Tube for side ratchet and side rotary drive lubricators. For right hand drive only	.25	799	Oil Strainer for pumping unit	.20
770-B	Drive bearing oiling tube for end rotary drive lubricators. For right hand drive only	.25	801	Nipple complete with quill. Specify dimension "A"	1.00
771-R. or L.	Spacing Collar. Specify whether lubricator has right or left hand drive	.30	803-A	Blind Bearing	.70
771-A	Spacing collar for drive side of partition. Specify whether for right or left hand drive lubricators	.30	C-804-R. or L.	Pawl carrier arm for front side ratchet drive complete with parts 738-A, 805-A, 805-B, 820-D and 848 shaft. Specify whether right or left hand drive. See illustration Fig. 9	2.50
771-B	Spacing collar for crank side of partition. Specify whether for right or left hand drive lubricators	.30	805-B	Furnished only with C-804 R. or L. and C-A-804 R. or L.	
772	Stuffing box packing	.05	C-806-R. or L.	Pawl carrier arm for end belt drive complete with 738-B Stud. Specify if for right or left hand drive	1.10
774	Copper gasket for 777	.10	C-807- $\frac{1}{4}$ "	Straight tube connector WITHOUT CHECK complete with 814, 818 and 819 for $\frac{1}{4}$ " O.D. Tube	.50
777	Plug for plunger hole	.05	C-A-807 $\frac{1}{4}$	Straight tube connector WITH CHECK complete with 814, 818 and 819 for $\frac{1}{4}$ " O. D. Tube	.70
778	No. 8 x 32 Brass Plug	.05			
779	$\frac{1}{4}$ " x 32 Brass Plug	.20			
786-B	Sight Feed Tube	.40			
787-B	Oil Receiving tube complete with cup	.40			

SYMBOL	NAME	PRICE	SYMBOL	NAME	PRICE
C-809- $\frac{1}{4}$	Angular barrel clamp connector WITHOUT CHECK. Complete with 814, 818 and 819 for $\frac{1}{4}$ " O.D. Tubing.	.80	879	$\frac{1}{4}$ -20 Hollow head set screw.	.15
C-A-809- $\frac{1}{4}$	Angular barrel clamp connector WITH CHECK. Complete with 814, 818 and 819 for $\frac{1}{4}$ " O.D. Tubing.	1.10	C-880-A	Adjusting spindle head, complete with 881 and 882.	.20
814	Connector check nut.	.10	883	$\frac{1}{4}$ "-32 nut for 789.	.05
817	Nipple for 900 check valve.	.10	884	Oval filler cup.	.25
818	Cinch nut for single cone ferrule. Specify outside diameter of tubing.	.05	C-884-F	Oval filler cup complete with 885-E and 952.	.50
A-818	Double cone cinch nut.	.05	884-H	Round filler cup (Not illustrated).	.50
819	Single cone ferrule. Specify diameter of tubing.	.05	C-885-A	Filler cup cover complete with chain.	.30
A-819	Double cone ferrule. Specify diameter of tubing.	.05	885-E	Oval filler cup cover.	.20
828	Spacing collar $\frac{3}{8}$ " O.D. x $\frac{1}{2}$ " I.D. Specify length.	.20	885-F	Round filler cup plug (Not illustrated).	.75
829	Stuffing box.	.45	886	Oval filler cup strainer.	.10
836	Set collar.	.10	C-890	Swivel complete with washer, cotter and set screw.	.45
838-A	Minimum adjusting spindle.	.10	891	Attachment arm. Specify dimension "A".	1.00
839	Minimum adjusting spindle spring.	.05	C-892	U Bolt with nuts.	.20
840	Spring for A-810 and A-811 (Not illustrated).	.05	C-A-900	Check valve complete $\frac{1}{8}$ " I.P.S. both ends.	1.75
841-A	Intermediate bearing $\frac{1}{8}$ " bore.	.60	C-B-900	Check valve complete $\frac{1}{4}$ " I.P. both ends.	1.75
841-B	Intermediate bearing $\frac{1}{8}$ " bore.	.65	C-908	Angle barrel clamp connection complete with 814. Having $\frac{1}{8}$ " male pipe thread both ends.	.50
841-C	Partition bearing.	.60	914	$\frac{1}{8}$ " I.P. Plug.	.05
842-A	Spacing collar for 841-B intermediate bearing.	.70	918	No. 1 x 1" Taper pin.	.05
842-B	Spacing collar for two compartment partition bearing.	.70	927	Hinge Link.	1.80
843	Gasket for 854.	.05	928	Hinge Link (Upper half).	1.90
846	Nut for 841-C.	.70	C-929	Hinge Link Pin, complete with spring cotters.	1.00
847	Packing ring.	.20	C-930	Extension adapter complete with 818 and 819.	1.00
848	Eccentric driving shaft. Furnished only with 804 R. or L. for side ratchet drive.	.05	952	Filler cup hinge ring.	.05
849	Bearing packing.	.05	C-995	Oil Dagger gauge. Specify dimension "A".	.80
850-A	$\frac{1}{8}$ "-18 x $\frac{3}{8}$ " Hex head cap screw.	.05	996	Glass Hood. Specify length overall, also, number of tubes covered by each glass required	.50
850-B	$\frac{1}{8}$ "-18 x $\frac{1}{4}$ " Hex head cap screw.	.05		1, 2 and 3 feed sizes .50	
852	$\frac{3}{8}$ x $\frac{1}{8}$ " Hex head cap screw.	.10		4 and 5 feed sizes .75	
853	Cover screw $\frac{1}{4}$ " Diameter.	.05		6 and 7 feed sizes .80	
853-B	Cover screw $\frac{1}{4}$ " Diameter.	.05	997	Glass hood clamp.	8 feed 1.00
854	$\frac{1}{4}$ x $\frac{3}{8}$ Round head cap screw.	.05	998	Glass hood gasket. Specify length overall.	.10
855	$\frac{1}{4}$ x $\frac{1}{2}$ " Spring cotter.	.05	C-1232-R. or L.	Drive pawl with stud for right or left hand drive. Specify which.	.90
857	No. 1 x $\frac{1}{4}$ " Split end taper pin.	.05	1233	Pawl wing stud. Furnished only with C-1232 R. or L.	.25
858	No. 1 x $\frac{3}{4}$ taper pin (Not illustrated).	.05	1270-A	Drive bearing oiling tube for side ratchet and side rotary drive lubricators. For left hand drive only.	.25
859	$\frac{1}{4}$ " Steel ball for A-807, A-809 and C-900.	.05	1270-B	Drive bearing oiling tube for end rotary drive lubricators. For left hand drive only.	.25
860	$\frac{1}{4}$ -20 Standard square nut.	.05			
861	Screw for 799.	.05			
863	1- $\frac{1}{8}$ " I.D. Composition gasket.	.05			
864	1- $\frac{1}{4}$ " I. D. Composition gasket.	.05			
865	Cover gasket. Specify length wanted.	.05			